

EPSON TERMINAL PRINTER

LQ-2170

SERVICE MANUAL

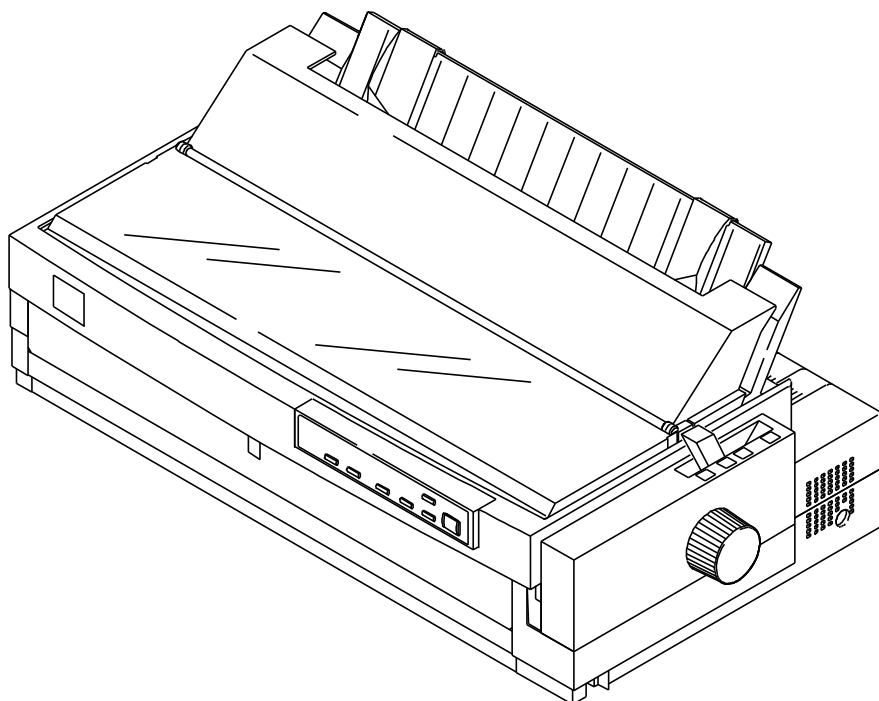

EPSON

4005735

NOTICE

- All right reserved. Reproduction of any part of this manual in any form wharsoever without SEIKO EPSON's express written permission is forbidden.
- The contents of this manual are subject to change without notice.
- All efforts have been made to ensure the accuracy of the contents of this manual. However, should any errors be detected, SEIKO EPSON would greatly appreciate being informed of them.
- The above notwithstanding SEIKO EPSON can assume no responsibility for any errors in this manual or the consequences thereof.

Copyright 1995 by SEIKO EPSON

CORPORATION
Nagano, Japan

PRECAUTIONS

Precautionary notations throughout the text are categorized relative to 1) personal injury, and 2) damage to equipment:

DANGER Signals a precaution which, if ignored, could result in serious or fatal personal injury. Great caution should be exercised in performing procedures preceded by a DANGER heading.

WARNING Signals a precaution which, if ignored, could result in damage to equipment.

The precautionary measures itemized below should always be observed when performing repair/maintenance procedures.

DANGER

1. ALWAYS DISCONNECT THE PRODUCT FROM BOTH THE POWER SOURCE AND THE HOST COMPUTER BEFORE PERFORMING ANY MAINTENANCE OR REPAIR PROCEDURE.
2. NO WORK SHOULD BE PERFORMED ON THE UNIT BY PERSONS UNFAMILIAR WITH BASIC SAFETY MEASURES AS DICTATED FOR ALL ELECTRONICS TECHNICIANS IN THEIR LINE OF WORK
3. WHEN PERFORMING TESTING AS DISCUSSED WITHIN THIS MANUAL, DO NOT CONNECT THE UNIT TO A POWER SOURCE UNIT INSTRUCTED TO DO SO. WHEN THE POWER SUPPLY CABLE MUST BE CONNECTED, USE EXTREME CAUTION IN WORKING ON POWER SUPPLY AND OTHER ELECTRONIC COMPONENTS.

WARNING

1. REPAIRS ON EPSON PRODUCT SHOULD BE PERFORMED ONLY BY AN EPSON CERTIFIED REPAIR TECHNICIAN.
2. MAKE CERTAIN THAT THE SOURCE VOLTAGE IS THE SAME AS THE RATED VOLTAGE, LISTED ON THE SERIAL NUMBER/RATING PLATE. IF THE EPSON PRODUCT HAS A PRIMARY-AC RATING DIFFERENT FROM THE AVAILABLE POWER SOURCE, DO NOT CONNECT IT TO THE POWER SOURCE.
3. ALWAYS VERIFY THAT THE EPSON PRODUCT HAS BEEN DISCONNECTED FROM THE POWER SOURCE BEFORE REMOVING OR REPLACING PRINTED CIRCUIT BOARDS AND/OR INDIVIDUAL CHIPS.
4. IN ORDER TO PROTECT SENSITIVE IC CHIPS AND CIRCUITRY, USE STATIC DISCHARGE EQUIPMENT, SUCH AS ANTI-STATIC WRIST STRAPS, WHEN ACCESSING INTERNAL COMPONENTS.
5. REPLACE MALFUNCTIONING COMPONENTS ONLY WITH THOSE COMPONENTS RECOMMENDED BY THE MANUFACTURER; INTRODUCTION OF SECOND-SOURCE ICs OR OTHER NONAPPROVED COMPONENTS MAY DAMAGE THE PRODUCT AND VOID ANY APPLICABLE EPSON WARRANTY.

PREFACE

This manual describes functions, theory of electrical and mechanical operations, maintenance, and repair of the FX-2170. The instructions and procedures included herein are intended for the experienced repair technician, and attention should be given to the precautions on the preceding page. The chapters are organized as follows:

- Chapter 1 - Provides a general product overview, Lists specifications, and illustrates the main components of the printer.
- Chapter 2 - Describes the theory of printer operation.
- Chapter 3 - Includes a step-by-step guide for product disassembly and assembly.
- Chapter 4 - Includes a step-by step guide for adjustment.
- Chapter 5 - Provides Epson-approved techniques for troubleshooting.
- Chapter 6 - Describes preventive maintenance techniques.

※ The contents of this manual are subject to change without notice.

REVISION SHEET

Revision	Issued Date	Revision Page
Rev. A	December 5, 1995	1st issued

TABLE OF CONTENTS

CHAPTER 1.	GENERAL DESCRIPTION
CHAPTER 2.	OPERATION PRINCIPLES
CHAPTER 3.	DISASSEMBLY AND ASSEMBLY
CHAPTER 4.	ADJUSTMENTS
CHAPTER 5.	TROUBLESHOOTING
CHAPTER 6.	MAINTENANCE
APPENDIX	

CHAPTER 1 Product Description

Table of Contents

1.1 Specifications	1-1
1.1.1 Features	1-1
1.1.2 Accessories	1-3
1.2 Hardware Specifications	1-4
1.2.1 Printing Method	1-4
1.2.2 Printing Specifications	1-5
1.2.3 Paper Handling Specifications	1-6
1.2.4 Paper Specifications	1-8
1.2.5 Ribbon Specifications	1-16
1.2.6 Electrical Specifications	1-16
1.2.7 Environmental Conditions	1-17
1.2.8 Reliability	1-17
1.2.9 Safety Approvals	1-17
1.2.10 CE Marking	1-18
1.2.11 Physical Specifications	1-18
1.2.12 Cut Sheet Feeder Specifications	1-18
1.3 Firmware Specifications	1-20
1.3.1 Control Codes and Fonts	1-20
1.3.2 Interface Specifications	1-21
1.3.2.1 Parallel Interface (Forward Channel)	1-21
1.3.2.2 Parallel Interface (Reverse Channel)	1-23
1.3.2.3 Interface Selection	1-24
1.3.2.4 Preventing the Host from Data Time-out	1-24
1.3.3 Paper Handling Firmware Specifications	1-25
1.3.4 Paper Width Sensor Operation	1-28
1.4 Operating Instructions	1-29
1.4.1 Control Panel Operation	1-29
1.4.2 Status Codes Indicated by the LEDs and Beeper	1-30
1.4.3 Micro Adjustment Function	1-31
1.4.4 Tear Off Function	1-31
1.4.5 Self-test Function	1-32
1.4.6 Hexadecimal Dump Function	1-32
1.4.7 Default Setting Function	1-33
1.4.8 EEPROM Clear Function	1-33
1.4.9 Bidirectional Adjustment Function	1-34
1.5 Initialization	1-34
1.5.1 Software Initialization	1-34
1.5.2 Operation Initialization	1-34
1.5.3 Power On Initialization	1-34

1.6 MAIN COMPONENTS	1-35
1.6.1 C165 MAIN Board Assembly	1-36
1.6.2 C165 PSB/PSE Board Assembly	1-36
1.6.3 C165 PNL Board Assembly	1-37
1.6.4 Printer Mechanism	1-37
1.6.5 Housing Assembly.	1-38

List of Figures

Figure 1-1. Exterior View of the LQ-2170	1-2
Figure 1-2. Pin Configuration	1-4
Figure 1-3. Printable Area for Cut Sheets	1-9
Figure 1-4. Printable Area for Envelopes and Card Stock	1-11
Figure 1-5. Printable Area for Continuous Paper	1-13
Figure 1-6. Label Size	1-14
Figure 1-7. Printable Area for Roll Paper	1-15
Figure 1-8. Data Transmission Timing	1-22
Figure 1-9. Control Panel	1-29
Figure 1-10. Self-test Printout	1-32
Figure 1-11. Hexadecimal Dump Printout	1-32
Figure 1-12. Main Components.	1-35
Figure 1-13. C165 MAIN Board Assembly	1-36
Figure 1-14. C165 PSB/PSE Board Assembly	1-36
Figure 1-15. C165 PNL Board Assembly	1-37
Figure 1-16. Printer Mechanism	1-37
Figure 1-17. Housing Assembly	1-38

List of Tables

Table 1-1. Items Included with the Printer	1-3
Table 1-2. Consumables	1-3
Table 1-3. Optional Units	1-3
Table 1-4. Print Speed and Printable Columns	1-5
Table 1-5. Print Resolution	1-5
Table 1-6. Paper Path and Paper Types	1-6
Table 1-7. Paper Thickness Lever Positions	1-7
Table 1-8. Specifications for Cut Sheets (Single Sheet, not Multipart)	1-8
Table 1-9. Specifications for Cut Sheets (Multipart)	1-8
Table 1-10. Printable Area for Cut Sheets	1-9
Table 1-11. Specifications for Envelopes	1-10
Table 1-12. Specifications for Card Stock	1-10
Table 1-13. Printable Area for Envelopes and Card Stock	1-11
Table 1-14. Specifications for Continuous Paper (Single Sheet and Multipart)	1-12
Table 1-15. Printable Area for Continuous Paper	1-13
Table 1-16. Specifications for Continuous Paper with Labels	1-14
Table 1-17. Specifications for Roll Paper	1-15
Table 1-18. Printable Area for Roll Paper	1-15
Table 1-19. Ribbon Specifications	1-16
Table 1-20. Electrical Specifications for 120 V Version	1-16
Table 1-21. Electrical Specifications for 220/240 V Version	1-16
Table 1-22. Environmental Conditions	1-17
Table 1-23. Reliability	1-17
Table 1-24. Safety Information for Printer Models	1-17
Table 1-25. CE Marking	1-18
Table 1-26. Physical Specifications	1-18
Table 1-27. Hopper Capacity	1-18
Table 1-28. Stacker Capacity	1-19
Table 1-29. Environmental Conditions	1-19
Table 1-30. Character Tables	1-20
Table 1-31. Pin Assignment of Forward Channel	1-21
Table 1-32. Minimum and Maximum Timings for Data Transmission	1-22
Table 1-33. Pin Assignments for Reverse Channel	1-23
Table 1-34. Paper Handling Sequence 1	1-25
Table 1-35. Paper Handling Sequence 2	1-25
Table 1-36. Paper Handling Sequence 3	1-26
Table 1-37. Paper Handling Sequence 4	1-26
Table 1-38. Paper Handling Sequence 5	1-27
Table 1-39. Paper Handling Sequence 6	1-27
Table 1-40. Paper Width Sensor Operation	1-28
Table 1-41. Operations in Normal Mode	1-29
Table 1-42. Operations at Power On	1-30
Table 1-43. Operations for Default Setting Mode	1-30
Table 1-44. Indicators and Beeper	1-30
Table 1-45. EEPROM Initialization Settings	1-33

1.1 Specifications

These specifications provide statistical information for the the LQ-2170 serial impact dot matrix printer.

1.1.1. Features

The LQ-2170 is a 24pin serial impact dot-matrix printer suitable for the VAR (value added reseller) market. The major features of this printer are:

Print speed	High speed draft	440 characters per second (cps)
	Draft	330 cps
	LQ	110 cps at 10 characters per inch (cpi)
Feeding method	Friction feed	(front, rear)
	Push tractor feed	(front, rear)
	Push and pull tractor feed	(front, rear)
	Pull tractor feed	(front, rear, bottom)
Feeder	Front push tractor, rear push tractor, CSF bin 1 / bin 2 (optional) Pull tractor (optional) , roll paper * holder (optional)	
Paper/media labels, roll paper	Single sheets, continuous paper, multipart paper, envelopes, card	
Fonts	9 LQ and 1 draft bitmap typefaces 8 barcode fonts	
Character tables	Standard version	11 tables
	NLSP version	20 tables
Input buffer	64KB	
Acoustic noise	53 dB (A), ISO 7779 pattern	
Reliability	Total print volume 7.5 million lines, except printhead MTBF 6000 power on hours (POH) Printhead life 400 million strokes/wire Ribbon life 8 million characters	
Interfaces	Bidirectional parallel interface (IEEE-P1284 nibble mode supported) Type B I /F Level 2 (option)	
Control codes	ESC/P2 and IBM 2390/2391 plus emulation	
Copy capability	1 original + 4 copies	
Control panel functions	Font, Pitch, Pause, Tear off, Bin, LF/FF, Load/Eject, Micro Adjust, Default setting	

Refer to Figure 1-1 on the next page for an exterior view of the FX-2170.

* Roll paper is not available on all models, and not available in the U.S.

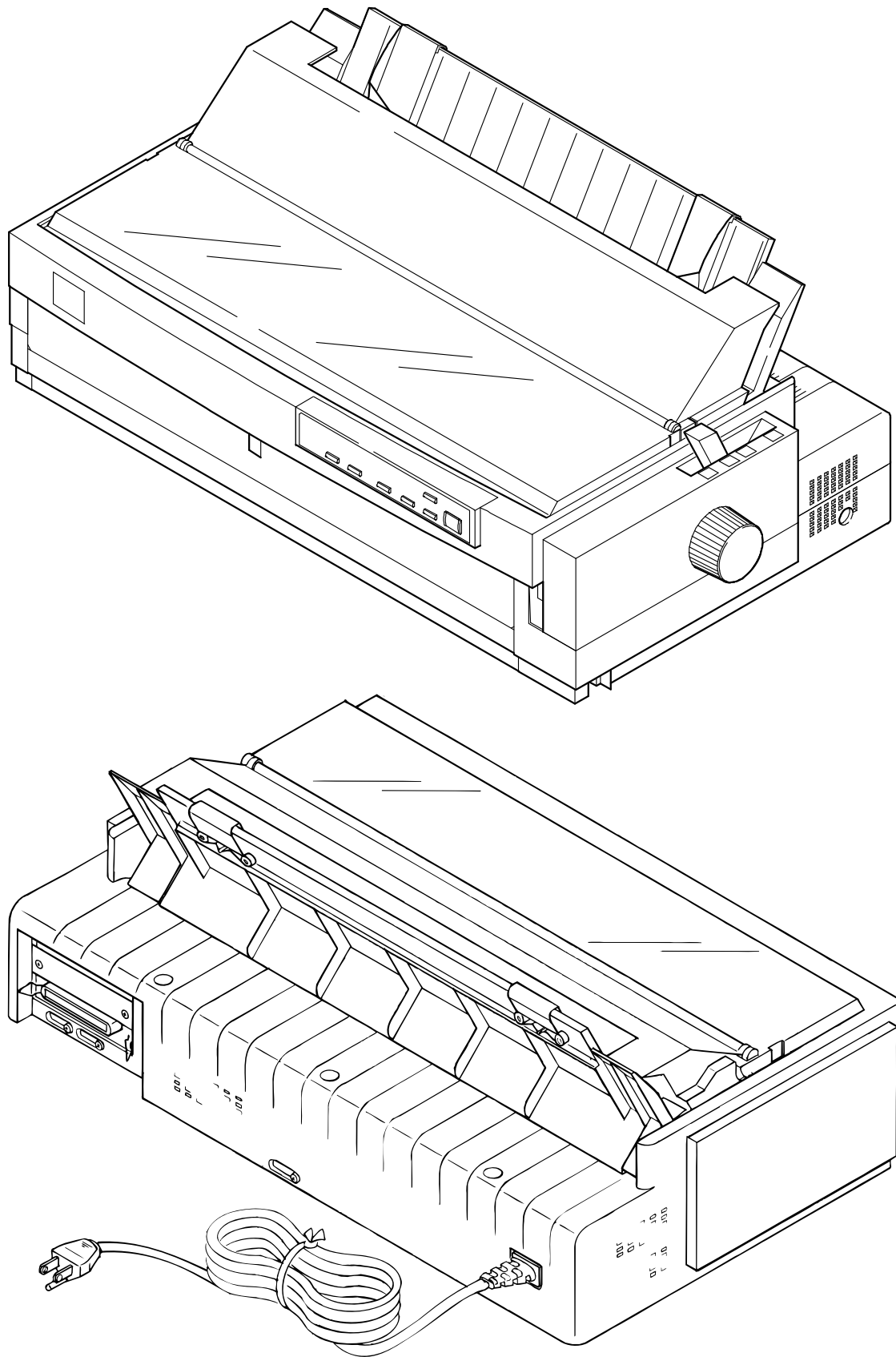

Figure 1-1 Exterior View of the LQ-2170

1.1.2. Accessories

- Items included in the printer carton

Table 1-1 Items Included with the Printer

Enclosed Items	Quantity
User's guide	1
Driver diskette	1
Ribbon cartridge	1
Power cord	1

- Consumables

Table 1-2 Consumables

Consumable Item	Part Number
Ribbon cartridge	S015083
Ribbon pack	S010031

- Options

Table 1-3 Optional Units

Unit	Description
High-capacity cut sheet feeder 1 (bin 1)	C80673*
Second bin cut sheet feeder 2 (bin 2)	C80674*
Pull tractor unit	C80032*
Roll paper holder	#8310
Serial I/F card	C82305* / C82306*
32KB intelligent serial I/F card	C82307* / C82308*
32KB intelligent parallel I/F card	C82310* / C82311*
Local Talk I/F card	C82312*
32KB IEEE-488 I/F card	C82313*
Coax I/F card	C82314*
Twinax I/F card	C82315*
Ethernet I/F card	C82331*

* The number represented by an asterisk varies, depending on the country.

1.2 Hardware Specifications

This section provides detailed hardware specifications for the LQ-2170.

1.2.1 Printing Method

Printing method	Impact dot matrix
Color	Black
Number of pins	24 pins
Pin arrangement	12 × 2 staggered
Pin diameter	0.21 mm (0.00083 inch)

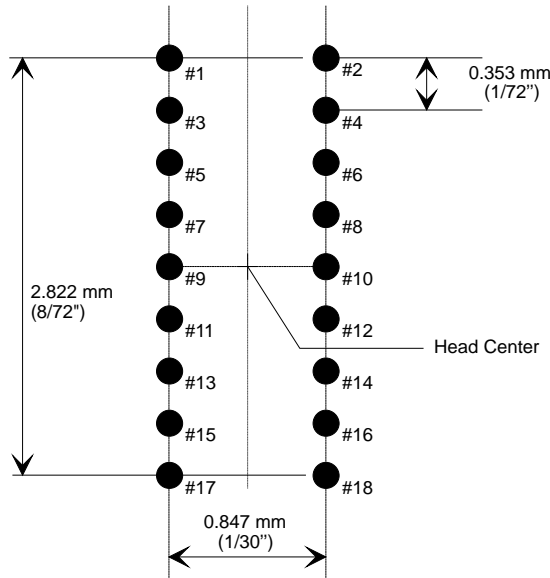

Figure 1-2. Pin Configuration

* The figure above shows the configuration of pins on the paper.

Print direction	Bidirectional, with logic seeking for text, and unidirectional for graphics. (Bidirectional printing of graphics can be selected with a printer setting or software command.)
------------------------	---

1.2.2 Printing Specifications

Copy capability

1 original + 4 copies

Print speed and printable columns

Table 1-4 Print Speed and Printable Columns

Print Mode	Character Pitch	Printable Columns	Print Speed (cps)	
			Normal	Multipart
High-speed draft	10 cpi	136	440	293
Draft	10 cpi	136	330	220
	12 cpi	163	396	264
	15 cpi	204	495	330
Draft condensed	17 cpi	233	283	189
	20 cpi	272	330	220
NLQ	10 cpi	136	110	73
	12 cpi	163	132	88
	15 cpi	204	165	110
LQ Condensed	17 cpi	233	189	126
	20 cpi	272	220	147

Resolution

Table 1-5 Print Resolution

Print Mode	Horizontal Density	Vertical Density	Adjacent Dot Printed?
High-speed draft	90 dpi	180 dpi	No
Draft	120 dpi	180 dpi	No
Draft condensed	240 dpi	180 dpi	No
NLQ	360 dpi	180 dpi	No
8 pin bit image	60, 80, 90, or 120 dpi	60 dpi	Yes
	120 or 240 dpi	60 dpi	No
24 pin bit image	60, 90, 120, or 180 dpi	180 dpi	Yes
	360 dpi	180 dpi	No
Raster graphics	180 or 360 dpi	180 or 360 dpi	Yes

Acoustic noise

53 dB (A), ISO 7779 pattern

1.2.3 Paper Handling Specifications

Feeding method	Friction feed	(front, rear)	
	Push tractor feed	(front, rear)	
	Push and pull feed	(front, rear, bottom)	
Feeder tractor (optional) and roll paper holder (optional)	Front push tractor, rear push tractor, CSF bin 1 /bin 2 (optional)		Pull
Paper path	Manual insertion	Front or rear in, top out	
	CSF	Rear in, top out	
	Tractor	Front, rear, or bottom in, top out	
Line spacing	1/6 inch or programmable in increments of 1/360 inch.		
Feed speed	1/6 inch feed	45 msec	
Continuous feed	0.127 m /sec (5.0 inches/sec)		
Release lever	Set the release lever, using the following table.		

Table 1-6 Paper Path and Paper Types

Lever Position	Paper Entrance	Paper Types				
		Single Sheet	Labels	Card Stock / Envelopes	Multipart	Roll Paper
Friction	Front insertion	OK	NO	OK *	OK	NO
	Rear insertion	OK	NO	OK	OK	NO
	CSF bin 1	OK	NO	OK	OK	NO
	CSF bin 2	OK	NO	NO	NO	NO
	Roll paper holder	NO	NO	NO	NO	OK
Front tractor	Push	OK	OK *	NO	OK	NO
	Push-pull	OK	OK *	NO	OK	NO
Rear tractor	Push	OK	OK *	NO	OK	NO
	Push-pull	OK	OK *	NO	OK	NO
Full release	Pull (front bottom)	OK	OK	NO	OK	NO
	Pull (rear)	OK	OK *	NO	OK	NO

* This symbol after "OK" means you need to check the paper type before using it with this paper path.

Paper thickness lever

Set the paper thickness lever to the appropriate position, as indicated in the following table.

Table 1-7 Paper Thickness Lever Positions

Lever Position	Paper Thickness (inches)		Paper Thickness (mm)	
	Minimum	Maximum	Minimum	Maximum
0	0.0024	0.0043	0.06	0.11
1	0.0047	0.0067	0.12	0.18
2	0.0075	0.0098	0.19	0.25
3	0.0102	0.0122	0.26	0.31
4	0.0126	0.0138	0.32	0.35
5	0.0142	0.0154	0.36	0.39
6	0.0157	0.0205	0.40	0.52

————— **Precautions for Handling Paper** —————

1. Friction feed

Set the release lever to the FRICTION position and install the paper eject assembly

Load paper from the front or top entrance.
not use continuous paper.

Do
Do not

perform any reverse paper feeds within the top 8.5 mm (0.33 inch) and bottom 22 mm (0.87 inch) area.

Do not perform reverse feeds greater than 1/6 inch after the paper end has been detected.

Use the paper-tension unit.

Insert the multipart cut sheet forms only from the front.

2. Push tractor feed

Set the release lever to the REAR PUSH/FRONT PUSH position and install the paper eject assembly.

Load paper from the rear or front entrance.

Release the friction feed mechanism.

Multipart paper must be carbonless.

the paper-tension unit.

perform reverse feeds greater than 1/6 inch.

Use
Do not

perform reverse feeds after the paper end has been detected, because accuracy of paper feeding cannot be assured.

Do not

3. Pull tractor feed

Set the release lever to the PULL position.

Load paper from the front, rear, or bottom entrance.
front or bottom entrance is recommended for thick paper or labels.)

(The

Remove the paper eject assembly and attach the pull tractor unit.

Insert paper from either from the front or bottom.

Multipart paper must be carbonless.

Do

not perform reverse feeds.

4. Push-pull tractor feed

Set the release lever to the REAR PUSH/FRONT PUSH position.
 Load paper from the front or rear entrance.
 the paper eject assembly and attach the pull tractor unit.
 any slack in the paper between the platen and pull tractor.
 horizontal position of the pull tractor and push tractor.
 carbonless.
 greater than 1/6 inch.
 after the paper end has been detected.

Remove
 Remove
 Precisely adjust the
 Multipart paper must be
 Do not perform reverse feeds
 Do not perform reverse feeds

1.2.4 Paper Specifications

This section describes the printable area and types of paper that can be used in this printer.

Cut Sheets

Paper/ media specifications The following table shows specifications for cut sheets.

Table 1-8 Specifications for Cut Sheets (Single Sheet, Not Multipart)

	Front Entry		Rear Entry	
	Minimum	Maximum	Minimum	Maximum
Width	101 mm (4.0")	420 mm (16.5")	101 mm (4.0")	420 mm (16.5")
Length	147 mm (5.8")	420 mm (16.5")	101 mm (4.0")	420 mm (16.5")
Thickness	0.065 mm(0.0025")	0.14 mm (0.0055")	0.065 mm(0.0025")	0.14 mm (0.0055")
Weight	52.3 g/m ² (14 lb)	90 g/m ² (24 lb)	52.3 g/m ² (14 lb)	90 g/m ² (24 lb)
Quality	Plain paper, recycled paper. Not curled, folded, or crumpled.		Plain paper, recycled paper. Not curled, folded, or crumpled.	

Table 1-9 Specifications for Cut Sheets (Multipart)

	Front Entry		Rear Entry	
	Minimum	Maximum	Minimum	Maximum
Width	101 mm (4.0")	420 mm (16.5")	101 mm (4.0")	420 mm (16.5")
Length	147 mm (5.8")	420 mm (16.5")	101 mm(4.0")	420 mm (16.5")
Copies	1 original + 4 copies		1 original + 4 copies	
Total thickness	0.12 mm (0.0047")	0.39 mm (0.015")	0.12 mm (0.0047")	0.39 mm (0.015")
Weight *	40 g/m ² (12 lb)	58 g/m ² (15 lb)	40 g/m ² (12 lb)	58 g/m ² (15 lb)
Quality	Plain paper, recycled paper. Not curled, folded, or crumpled.		Plain paper, recycled paper. Not curled, folded, or crumpled.	
Binding	A line of glue at the top or one side of the form.		A line of glue at the top of the form.	

* This weight is for one sheet of the multipart form.

Printable area

Figure 1-3 shows the printable area for cut sheets. The table below defines the abbreviations used in the figure.

Table 1-10 Printable Area for Cut Sheets

Abbreviations	Single Sheet	Multipart
PW (width)	Refer to Table 1-8.	Refer to Table 1-9.
PL (length)	Refer to Table 1-8.	Refer to Table 1-9.
LM (left margin)	3 mm (0.12") or more (PW ≤ 364 mm (14.33")) 25 mm (0.98") or more (PW = 420 mm (16.5"))	3 mm (0.12") or more (PW ≤ 364 mm (14.33")) 25 mm (0.98") or more (PW = 420 mm (16.5"))
RM (right margin)	3 mm or more (PW ≤ 364 mm (14.33")) 25 mm (0.98") or more (PW = 420 mm (16.5"))	3 mm or more (PW ≤ 364 mm (14.33")) 25 mm (0.98") or more (PW = 420 mm (16.5"))
TM (top margin)	4.2 mm (0.17") or more	4.2 mm (0.17") or more
BM (bottom margin)	4.2 mm (0.17") or more	4.2 mm (0.17") or more

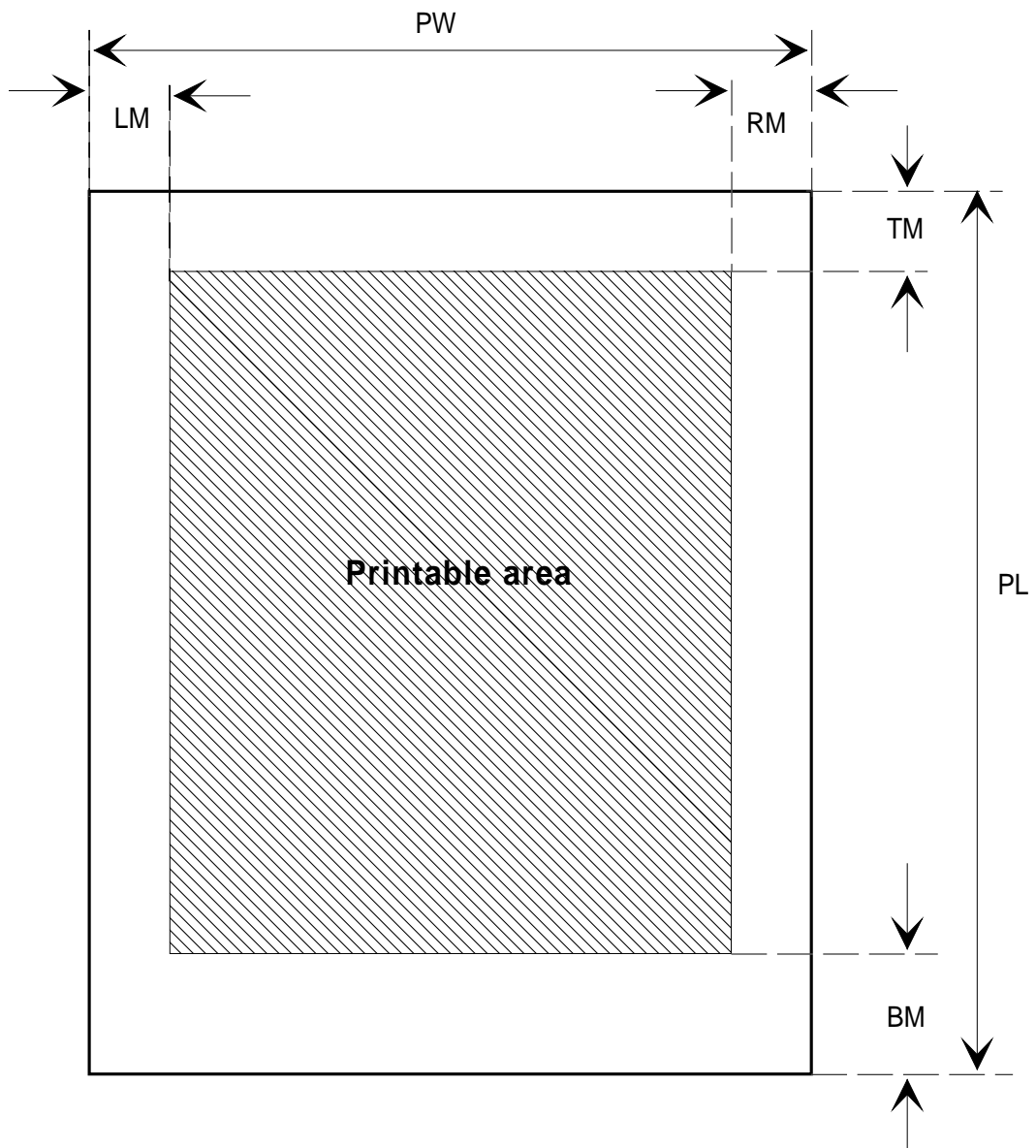

Figure 1-3 Printable Area for Cut Sheets

Envelopes and Card Stock

Paper/media specifications The following tables gives specifications for envelopes and card stock.

Table 1-11 Specifications for Envelopes

		Front Entry		Rear Entry	
		Minimum	Maximum	Minimum	Maximum
No. 6 envelopes	Width	---		166 mm (6.5")	
	Length	---		92 mm (3.6")	
No. 10 envelopes	Width	---		240 mm (9.5")	
	Length	---		104 mm (4.1")	
Total thickness		---	---	0.16 mm (0.0063")	0.52 mm (0.020")
		---		Differences in thickness in the printable area must be within 0.25 mm (0.0098").	
Weight		---	---	45 g/m ² (12 lb)	91 g/m ² (24 lb)
Quality		---		Bond paper, plain paper, or airmail. No glue at the flap. Not curled, folded, or crumpled.	

- * Printing on envelopes is available only at normal temperatures and humidity.
- * Insert envelopes from the rear entrance only.
- * Insert the longer side of the envelope horizontally.

Table 1-12 Specifications for Card Stock

	Front Entry		Rear Entry	
	Minimum	Maximum	Minimum	Maximum
Width	105 mm (4.13")	148 mm (5.83")	105 mm (4.13")	148 mm (5.83")
Length	148 mm (5.83")	148 mm (5.83")	105 mm (4.13")	148 mm (5.83")
Thickness	0.22 mm (0.0087")		0.22 mm (0.0087")	
Weight	192 g/m ² (51 lb)		192 g/m ² (51 lb)	
Quality	Plain paper, recycled paper. Not curled, folded, or crumpled.		Plain paper, recycled paper. Not curled, folded, or crumpled.	

- * Printing on card stock is available only at normal temperatures and humidity.
- * When the longer side of an A6 card is to be inserted horizontally, insert it from the rear entrance.

Printable area

The figure below shows the printable area for envelopes and card stock.
Each abbreviation is defined in the following table.

Table 1-13 Printable Area for Envelopes and Card Stock

Abbreviations	Envelopes	Card Stock
PW (width)	Refer to Table 1-11.	Refer to Table 1-12.
PL (length)	Refer to Table 1-11.	Refer to Table 1-12.
LM (left margin)	3 mm (0.12") or more	3 mm (0.12") or more
RM (right margin)	3 mm (0.12") or more	3 mm (0.12") or more
TM (top margin)	4.2 mm (0.17") or more	4.2 mm (0.17") or more
BM (bottom margin)	4.2 mm (0.17") or more	4.2 mm (0.17") or more

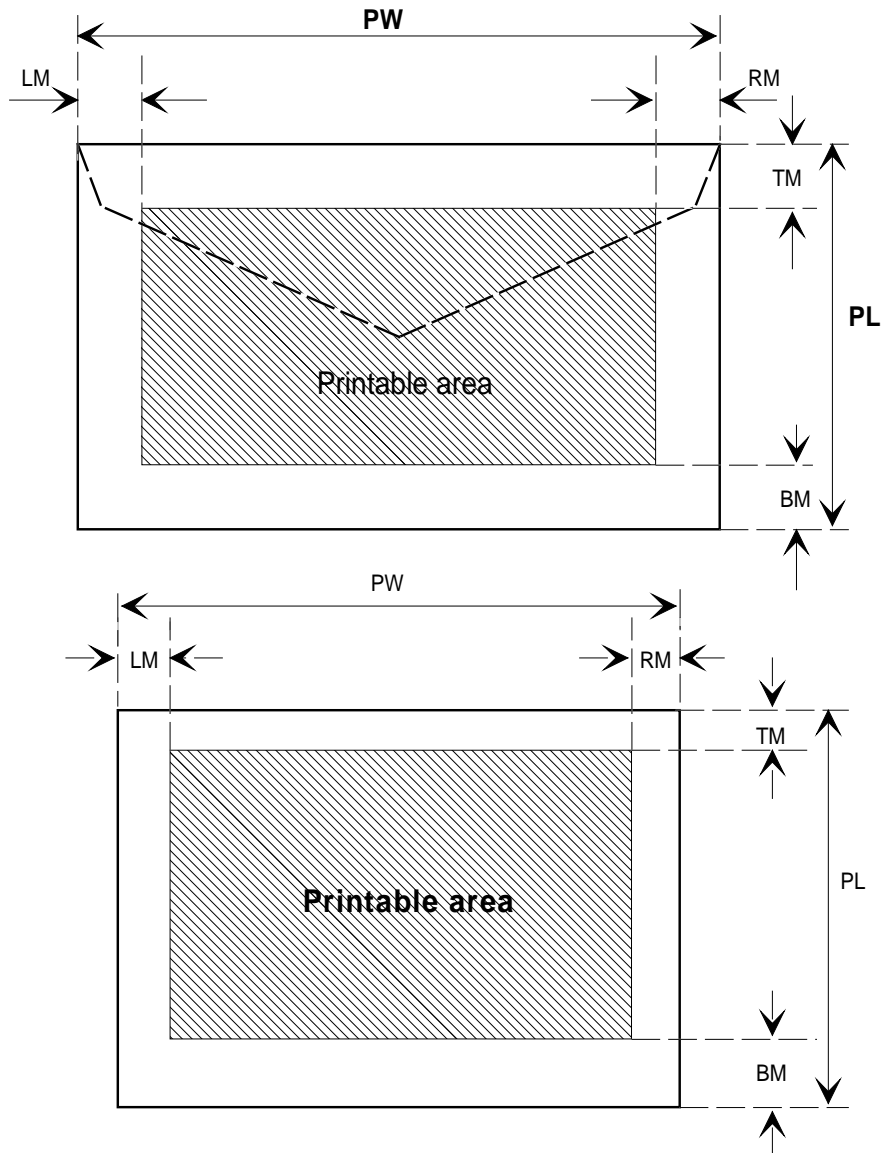

Figure 1-4 Printable Area for Envelopes and Card Stock

Continuous Paper

Paper/media specifications The following table gives specifications continuous paper.

Table 1-14 Specifications for Continuous Paper (Single Sheet and Multipart)

	Front Entry		Rear Entry		Bottom Entry	
	Minimum	Maximum	Minimum	Maximum	Minimum	Maximum
Width	101 mm (4.0")	406 mm (16")	101 mm (4.0")	406 mm (16")	101 mm (4.0")	406 mm (16")
Length	101 mm (4.0")	559 mm (22")	101 mm (4.0")	559 mm (22")	101 mm (4.0")	559 mm (22")
Copies	1 original + 4 copies		1 original + 4 copies		1 original + 4 copies	
Total thickness	0.065 mm (0.0025")	0.39 mm (0.015")	0.065 mm (0.0025")	0.39 mm (0.015")	0.065 mm (0.0025")	0.39 mm (0.015")
Weight (not multipart)	52.3 g/m ² (14 lb)	82 g/m ² (22 lb)	52.3 g/m ² (14 lb)	82 g/m ² (22 lb)	52.3 g/m ² (14 lb)	82 g/m ² (22 lb)
Weight (one sheet of a multipart form)	40 g/m ² (12 lb)	58 g/m ² (15 lb)	40 g/m ² (12 lb)	58 g/m ² (15 lb)	40 g/m ² (12 lb)	58 g/m ² (15 lb)
Types of paper	Plain paper. Recycled paper. Carbonless multipart.		Plain paper. Recycled paper. Carbonless multipart.		Plain paper. Recycled paper. Carbonless multipart.	
Binding	Dots of glue or paper staples (both sides).		Dots of glue or paper staples (both sides).		Dots of glue or paper staples (both sides).	

Printable area

The figure below shows the printable area for continuous paper.
Each abbreviation is defined in the following table.

Table 1- 15 Printable Area for Continuous Paper

Abbreviations	Continuous Paper
PW (width)	Refer to Table 1-14.
PL (length)	Refer to Table 1-14.
LM (left margin)	13 mm (0.51") or more
RM (right margin)	13 mm (0.51") or more
TM (top margin)	4.2 mm (0.17") or more
BM (bottom margin)	4.2 mm (0.17") or more

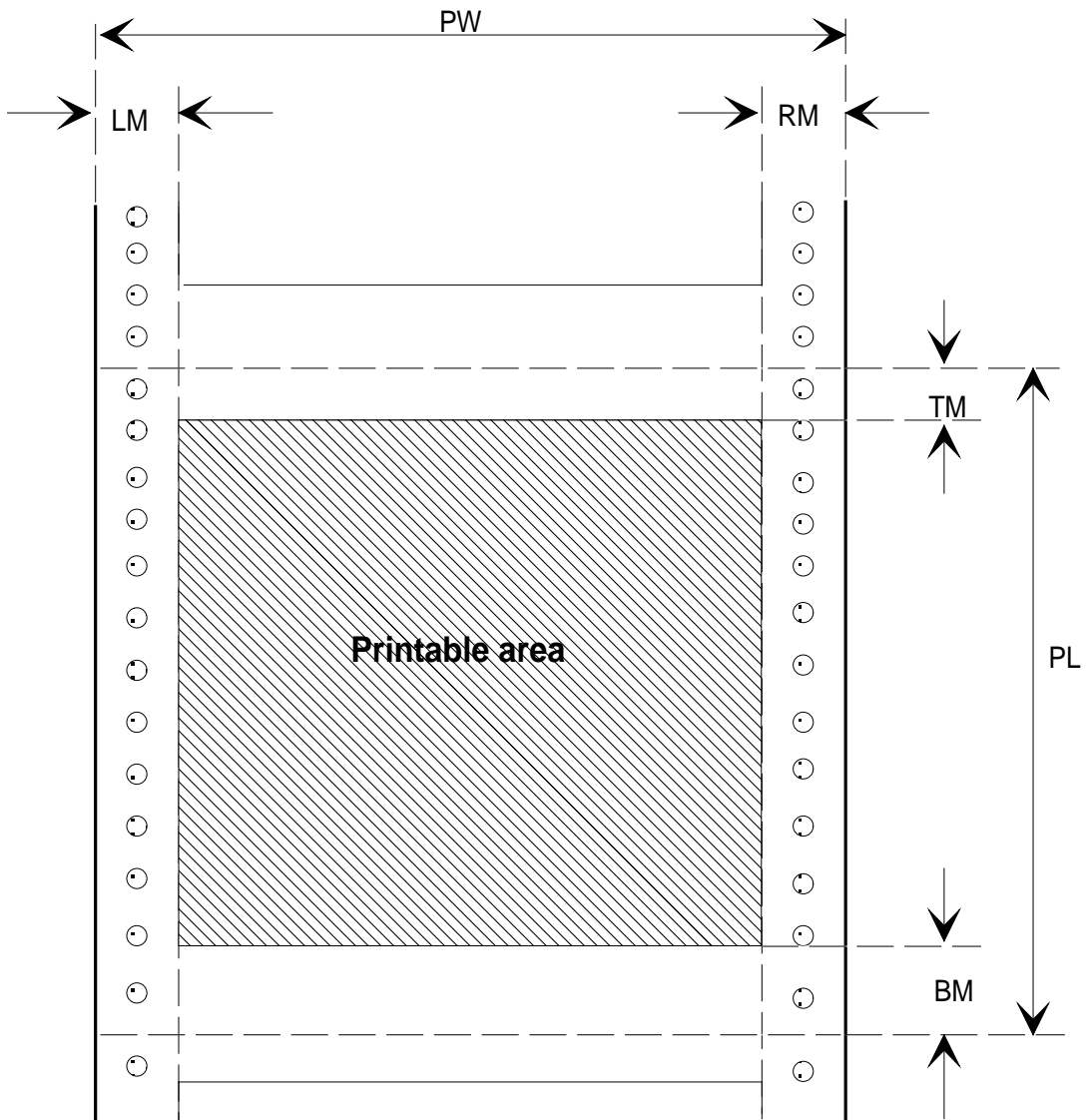

Figure 1-5 Printable Area for Continuous Paper

Continuous Paper with Labels

Paper/media specifications The following table gives the specifications for continuous paper with labels.

Table 1-16 Specifications for Continuous Paper with Labels

	Front Entry		Rear Entry		Bottom Entry	
	Minimum	Maximum	Minimum	Maximum	Minimum	Maximum
Label size	See the figure below		---		See the figure below	
Base sheet width	101 mm (4.0")	406 mm (16")	---	---	101 mm (4.0")	406 mm (16")
Base sheet length (one page)	101 mm (4.0")	559 mm (22")	---	---	101 mm (4.0")	559 mm (22")
Base sheet thickness	0.07 mm (0.0028")	0.09 mm (0.00352)	---	---	0.16 mm (0.0063")	0.19 mm (0.0075")
Total thickness	0.16 mm (0.0063")	0.19 mm (0.0075")	---	---	0.16 mm (0.0063")	0.19 mm (0.0075")
Label weight	68 g/m ² (17 lb)		---		68 g/m ² (17 lb)	
Quality	Avery continuous form labels Avery mini-line or equivalent quality labels		---		Avery continuous form labels Avery mini-line or equivalent quality labels	

- * Printing on labels is available only at normal temperatures and humidity.
- * The base sheet for the labels must be continuous paper.
- * Continuous paper with labels should be inserted from the front or bottom entrance.



Figure 1-6 Label Size

Printable size and area

The figure above is the printable size for the labels.

The printable area for the base sheet containing the labels depends on conditions in Figure 1-5 and Table 1-15.

Roll Paper

Note: Roll paper is not available in all models, and not available in the U.S.

Paper/media specifications The following table shows specifications for roll paper.

Table 1-17 Specifications for Roll Paper

	Front Entry		Rear Entry	
	Minimum	Maximum	Minimum	Maximum
Width	—		216 mm (8.5")	
Length	—		—	
Thickness	—	—	0.07 mm (0.0028")	0.09 mm (0.0035")
Weight	—	—	52.3 g/m ² (14 lb)	82 g/m ² (22 lb)
Quality	—		Plain paper, recycled paper. Not curled, folded, or crumpled.	

Printable area

Figure 1-7 gives the printable area for roll paper.
Each abbreviation is defined in the following table.

Table 1-18 Printable Area for Roll Paper

Abbreviations	Roll Paper
PW (width)	See Table 1-17.
PL (length)	See Table 1-17.
LM	3 mm (0.12") or more
RM	3 mm (0.12") or more
TM	4.2 mm (0.17") or more
BM	4.2 mm (0.17") or more

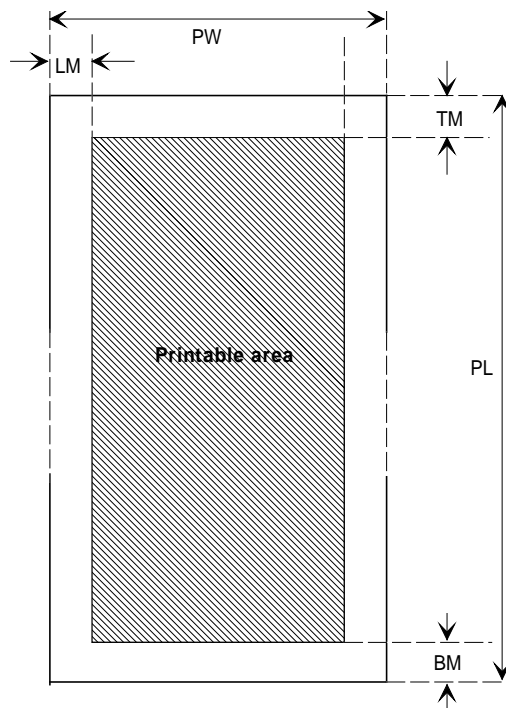

Figure 1-7 Printable Area for Roll Paper

1.2.5 Ribbon Specifications

Table 1-19 Statistics on the Ribbon

Item	Specification
Type	Fabric
Color	Black
Ribbon life	8 million characters (draft, 10 cpi, 48 dots/ character)
Dimension	506.0 mm (W) × 123.5 mm (D) × 23.0 mm (H) 19.92" (W) x 4.86" (D) x .91" (H)

1.2.6 Electrical Specifications

Tables 1-20 and 1-21 provide statistics on electrical ratings and consumption.

Table 1-20 Electrical Specifications for the 120 V Version

Item	Specifications
Rated voltage	120 VAC
Input voltage range	103.5 to 132 VAC
Rated frequency range	50 to 60 Hz
Input frequency range	49.5 to 60.5 Hz
Rated current	1.0 A (max. 2.6 A)
Power consumption	Approx. 62 W (self-test in draft mode at 10 cpi)
Insulation resistance	10 MΩ min. (between AC line and chassis, 500 VDC)
Dielectric strength	1000 VAC rms. 1 min. or 1200 VAC rms. 1 sec. (between AC line and chassis)

Table 1-21 Electrical Specifications for the 220/240 V Version

Item	Specifications
Rated voltage	220 to 240 VAC
Input voltage range	198 to 264 VAC
Rated frequency range	50 to 60 Hz
Input frequency range	49.5 to 60.5 Hz
Rated current	0.5 A (maximum 1.3 A)
Power consumption	Approx. 62 W (self-test in draft mode at 10 cpi)
Insulation resistance	10 MΩ min. (between AC line and chassis, 500 VDC)
Dielectric strength	1500 VAC rms. 1 min. (between AC line and chassis)

1.2.7 Environmental Conditions

Table 1-22 explains the conditions the printer requires during operation and when not operating.

Table 1-22 Environmental Requirements

Item	Specifications
Temperature	5 to 35° C/41 to 95° F (operating * 1) 15 to 25° C/59 to 77° F (operating * 1, * 2) -30 to 60° C/-22 to 140° F (non-operating)
Humidity	10 to 80 % RH (operating * 1) 30 to 60 % RH (operating * 1, * 2) 0 to 85 % RH (non-operating * 1)
Resistance to shock	1 G, within 1 ms (operating) 2 G, within 2 ms (non-operating * 3)
Resistance to vibration	0.25 G, 10 to 55 Hz (operating) 0.50 G, 10 to 55 Hz (non-operating * 3)

* 1: Without condensation.

* 2: During printing on multipart paper, envelopes, card stock, or labels.

* 3: In shipment container.

1.2.8 Reliability

Table 1-23 gives maximum life and usage specifications.

Table 1-23 Reliability Statistics

Item	Specification
Total print volume	7.5 million lines (except printhead)
MTBF	6000 power on hours (POH)
Printhead life	400 million strokes / wire
Ribbon life	8 million characters

1.2.9 Safety Approvals

Table 1-24 provides information about the safety approvals the printer has met.

Table 1-24 Safety Information for Printer Models

	120 V	230 V
Safety Standards	UL1950 with D3 CSA C22.2 No.950 with D3	EN60950 (TüV. SEMKO, DEMKO, NEMKO, FIMKO)
EMI	FCC part 15 subpart B class B CSA C108.8	EN55022 (CISPR pub.22) class B

1.2.10 CE Marking

The following table lists CE marking information.

Table 1-25 CE Marking

Low Voltage Directive 73/23 / EEC	EN60950
EMC Directive 89/336 / EEC	EN55022 class B EN50082-1 , IEC801-2 IEC801-3 , IEC801-4
Non-Automatic Weighing Instruments Directive 90/384/EEC	EN45501

1.2.11 Physical Specifications

Table 1-26 provides printer dimensions and weight.

Table 1-26 Physical Specifications

Dimensions	639 mm (W) × 410 mm (D) × 257 mm (H) 25.16" (W) x 16.14" (D) x 10.12" (H)
Weight	Approx. 13 kg (28.66 lb)

1.2.12 Cut Sheet Feeder Specifications

This printer has two CSF options: a high-capacity CSF and a 2nd bin CSF. The high-capacity CSF has special a paper-feed motor to load the paper quickly. The 2nd bin CSF can be connected to the high-capacity CSF to allow them to be used as a double bin CSF. The following table provides the specifications for these CSF options.

Hopper capacity

Table 1-27 Hopper Capacity

	CSF Bin 1	CSF Bin 2
Single sheets	150 sheets (※ 1) / 110 sheets (※ 2) 185 sheets (※ 3) / 135 sheets (※ 4)	50 sheets (※ 1) / 50 sheets (※ 2) 60 sheets (※ 3) / 60 sheets (※ 4)
Envelopes	25 sheets (※ 5) 30 sheets (※ 6)	---
Card stock	50 sheets (※ 7)	---
Multipart paper	40 sheets (※ 8)	---

※ 1 : Plain paper (weight: 82 g/m², 22 lb) or recycled paper, except for A3-size paper.

※ 2 : Plain paper (weight: 82 g/m², 22 lb) or recycled paper, A3 paper.

※ 3 : Plain paper (weight: 64 g/m², 17 lb) , except for A3 paper.

※ 4 : Plain paper (weight: 64 g/m², 17 lb), A3 paper.

※ 5 : Envelopes (weight: 91 g/m², 24 lb)

※ 6 : Envelopes (weight: 45 g/m², 12 lb)

※ 7 : Card stock (weight: 192 g/m², 51 lb; thickness: 0.22 mm, 0.0087")

※ 8 : 1 original + 5 copies (thickness: 0.36 mm, 0.0142")

Stacker capacity

Table 1-28 Capacity of the Stacker

	CSF Bin 1	CSF Bin 2
Single sheets	140 sheets (* 1) 100 sheets (* 2)	—
Envelopes	15 sheets (* 3) 28 sheets (* 4)	—
Card stock	30 sheets (* 5)	—
Multipart	36 sheets (* 6)	—

* 1: Single sheets (weight: 82 g/m², 22 lb), except for A3 paper* 2: Single sheets (weight: 82 g/m², 22 lb), A3 paper* 3: Envelopes (weight: 91 g/m², 24 lb)* 4: Envelopes (weight: 45 g/m², 12 lb)* 5: Card stock (weight : 192 g/m², 51 lb; thickness: 0.22 mm, 0.0087")

* 6: 1 original + 5 copies (thickness: 0.36 mm, 0.0142")

Reliability

MCBF: 2×10^5 cycles

Environmental conditions

Table 1-29 Environmental Conditions

	Operating	Non Operating
Temperature	5 to 35° C (41 to 95° F)	-30 to 60° C (-22 to 140° F)
Humidity	15 to 80% RH (* 1, * 3) 30 to 60% RH (* 2, * 4)	5 to 85% RH (* 3)

* 1: Single sheets (plain, 64 g/m² < weight < 82 g/m²; 17 lb < weight < 22 lb)* 2: Single sheets (plain, weight < 64 g/m², 82 g/m² < weight/weight < 17 lb, 22 lb < weight)

Single sheets (recycled), multipart, envelopes, and card stock

* 3: Without condensation

1.3 Firmware Specifications

This section provides detailed information about LQ-2170 firmware.

1.3.1 Control Codes and Fonts

Control codes ESC/P2 and IBM 2390/2391 plus emulations.

Typefaces

Bitmap fonts

EPSON Draft	10 cpi, 12 cpi, 15 cpi
EPSON Roman	10 cpi, 12 cpi, 15 cpi, proportional
EPSON Sans Serif	10 cpi, 12 cpi, 15 cpi, proportional
EPSON Courier	10 cpi, 12 cpi, 15 cpi,
EPSON Prestige	10 cpi, 12 cpi
EPSON Script	10 cpi
EPSON OCR-B	10 cpi
EPSON Orator	10 cpi
EPSON Orator-S	10 cpi
EPSON Script C	Proportional

Scalable font

EPSON Roman	10.5pt., 8pt.-32pt. (every 2 pt.)
EPSON Sans Serif	10.5pt., 8pt.-32pt. (every 2pt.)
EPSON Roman T	10.5pt., 8pt.-32pt. (every 2pt.)
EPSON Sans Serif H	10.5pt., 8pt.-32pt. (every 2pt.)

Bar code fonts

EAN-13, EAN-8, Interleaved 2 of 5, UPC-A, UPC-E, Code 39
Code 128, POSTNET

International character sets 13 countries

U.S.A., France, Germany, U.K., Denmark 1, Sweden, Italy,
Spain 1, Japan, Norway, Denmark2, Spain2, Latin America

Character tables The standard version has 11 character tables and the NLSP version has 20 character tables, as shown in the following table.

Table 1-30 Character Tables

Version	Character Tables		
Standard Version	Italic	PC-437 (U.S., Standard Eur.)	PC-850 (Multilingual)
	PC-860 (Portuguese)	PC-861 (Icelandic)	PC-863 (Canadian-French)
	PC-865 (Nordic)	Abicomp	BRASCII
	Roman 8	ISO Latin 1	
NLSP Version	Italic	PC-437 (US, Standard Eur.)	PC-850 (Multilingual)
	PC-437 Greek	PC-852 (East Europe)	PC-853 (Turkish)
	PC-855 (Cyrillic)	PC-857 (Turkish)	PC-866 (Russian)
	PC-869 (Greek)	MAZOWAI (Poland)	Code MJK (CSFR)
	ISO 8859-7 (Latin/Greek)	ISO Latin 1T (Turkish)	Bulgaria (Bulgarian)
	Estonia (Estonia)	PC-744(LST 1283:1993)	ISO Latin 2
	PC-866 LAT (Latvia)	PC-864 (Arabic)	

1.3.2 Interface Specifications

This printer provides a bidirectional 8-bit parallel interface and a Type B optional interface slot, standard.

1.3.2.1 Parallel Interface (Forward Channel)

Transmission mode	8-bit parallel, IEEE-P1284, compatibility mode
Adaptable connector	57-30360 (Amphenol) or equivalent
Synchronization	$\overline{\text{STROBE}}$ pulse
Handshaking	BUSY and $\overline{\text{ACKNLG}}$ signals
Signal level	TTL compatible (IEEE-P1284 level 1 device)

Table 1-31 Pin Assignments for Forward Channel

Pin No.	Signal Name	Return GND pin	In /Out	Function Description
1	$\overline{\text{STROBE}}$	19	In	Strobe pulse. Input data is latched at falling edge of the signal
2	DATA1	20	In	Parallel input data to the printer bit 0: LSB
3	DATA2	21	In	bit 1
4	DATA3	22	In	bit 2
5	DATA4	23	In	bit 3
6	DATA5	24	In	bit 4
7	DATA6	25	In	bit 5
8	DATA7	26	In	bit 6
9	DATA8	27	In	bit 7: MSB
10	$\overline{\text{ACKNLG}}$	28	Out	This signal (negative pulse) indicates the printer has received data and is ready to accept more data.
11	BUSY	29	Out	This signal's HIGH level means the printer is not ready to accept data.
12	PE	28	Out	This signal's HIGH level means the printer has a paper-out error.
13	SLCT	28	Out	Always HIGH when the printer is powered on.
14	$\overline{\text{AFXT}}$	30	In	Not used.
31	$\overline{\text{INIT}}$	30	In	This signal's negative pulse initializes printer.
32	$\overline{\text{ERROR}}$	29	Out	This signal's LOW level means the printer is in an error state.
36	$\overline{\text{SLIN}}$	30	In	Not used.
18	Logic H	—	Out	This line is pulled up to + 5 V through 3.3K Ω resistor.
35	+5V	—	Out	This line is pulled up to +5 V through 3.3K Ω resistor.
17	Chassis	—	—	Chassis GND.
16, 33, 19-30	GND	—	—	Signal GND.
15, 34	NC	—	—	Not connected.

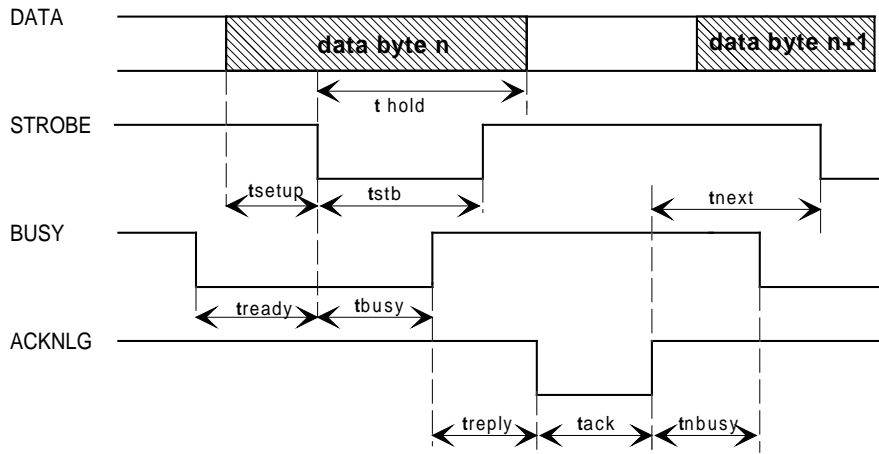

Figure 1-8 Data Transmission Timing

Table 1-32 Maximum and Minimum Timings for Data Transmission

Parameter	Minimum	Maximum
setup	500 nsec	—
thold	500 nsec	—
t stb	500 nsec	—
tready	0	—
tbusy	—	500 nsec
treply	—	—
tack	500 nsec	10 μs
tnbusy	0	—
tnext	0	—
ttout	—	120 nsec
ttin	—	200 nsec

The BUSY signal is active (HIGH level) under the conditions below:

- During data receipt.
- If the input buffer is full.
- If the INIT signal is active (LOW level).
- During hardware initialization.
- In self-test mode.
- In adjustment mode.
- In default-setting mode.

The ERROR signal is active (LOW level) under the conditions below:

- If there is a fatal error.
- If there is a paper-out error.
- If the cover is open (cover open error).

PE signal is active (HIGH level) under the conditions below:

- If there is a paper-out error.

1.3.2.2 Parallel Interface (Reverse Channel)

Transmission mode	IEEE-P1284 nibble mode
Adaptable connector	57-30360 (Amphenol) or equivalent
Synchronization	Refer to the IEEE-P1284 Specification
Handshaking	Refer to the IEEE-P1284 Specification
Signal level	TTL-compatible (IEEE-P1284 level 1 device)
Data transmission timing	Refer to the specification

Table 1-33 Pin Assignments for Reverse Channel

Pin No,	Signal Name	Return GND Pin	In /Out	Function Description
1	HostClk	19	In	Host clock signal.
2	DATA1	20	In	Parallel input data to the printer bit 0: LSB
3	DATA2	21	In	bit 1
4	DATA3	22	In	bit 2
5	DATA4	23	In	bit 3
6	DATA5	24	In	bit 4
7	DATA6	25	In	bit 5
8	DATA7	26	In	bit 6
9	DATA8	27	In	bit 7: MSB
10	PtrClk	28	Out	Printer clock signal.
11	PtrBusy / DataBit-3, 7	29	Out	Printer busy signal and reverse channel transfer of data bits 3 or 7
12	AckDataReq/ DataBit-2, 6	28	Out	Acknowledge data request signal and reverse channel transfer of data bits 2 or 6
13	Xflag / DataBit-1, 5	28	Out	X-flag signal and reverse channel transfer of data bits 1 or 5
14	HostBusy	30	In	Host busy signal.
31	INIT	$\overline{30}$	In	Not used.
32	DataAvail / DataBit-0, 4	29	Out	Data available signal and reverse channel transfer of data bits 0 or 4
36	1284-Active	30	In	1284 active signal.
18	Logic H	—	Out	This line is pulled up to + 5 V through 3.3K Ω resistor.
35	+5 V	—	Out	This line is pulled up to +5 V through 3.3K Ω resistor.
17	Chassis	—	—	Chassis GND.
16, 33, 19-30	GND	—	—	Signal GND.
15, 34	NC	—	—	Not connected.

- **Extensibility request** The printer responds to the extensibility request in the affirmative, when the request is 00 H or 04 H, which means:

00 H	Request nibble mode of reverse channel transfer.
04 H	Request device ID in nibble mode of reverse channel transfer.

- **Device ID** Refer to the following descriptions:

ESC/P2	[00 H][32 H]	MFG: EPSON, CMD: ESCPL2-00, MDL: LQ-2170, CLS: PRINTER
IBM 2391 Plus	[00 H][33 H]	MFG: EPSON, CMD: PRPXL24-01, MDL: LQ-2170, CLS: PRINTER

1.3.2.3 Interface Selection

The printer has 2 interfaces: the parallel interface and Type B optional interface. These interfaces are selected manually in default setting mode or selected automatically.

Manual selection

One of 2 interfaces can be selected in default setting mode.

Automatic selection

Automatic interface is enabled in default setting mode. In automatic interface mode, the printer is initialized to the idle state, where it scans which interface is to be activated. The interface that receives data first is selected. When the host stops data transfer, and the printer is in standby for a number of seconds specified in default setting mode, the printer returns to the idle state. As long as the host sends data or the printer interface is busy, the selected interface remains active.

Interface state and interface selection

When the parallel interface is not selected, that interface goes into a busy state. When the Type B serial interface card is installed and it is not selected, the interface sends an XOFF code and sets the DTR signal to MARK. When the optional interface is not selected, the printer sends disable commands to the optional interface. When the printer is initialized or returned to the idle state, the parallel interface goes into the ready state, the serial interface sends an XON code and sets the DTR signal to SPACE, and the printer sends an enable command to the optional interface. Remember that interrupt signals, such as the INIT signal on the parallel interface, are not effective unless that interface is selected.

1.3.2.4 Prevention Hosts from Data Transfer Time-out

Generally, hosts abandon data transfer to peripherals when the peripheral is in the busy state for dozens of seconds continuously. To prevent hosts from this kind of time-out, the printer receives data very slowly, several bytes per minute, even if the printer is in the busy state. This slowdown is started when the rest of the input buffer becomes several hundreds of bytes. Finally, when the input buffer is full, the printer is in busy continuously.

1.3.3 Paper Handling Sequence

In this section, paper handling firmware sequences are described in several cases.

- **Printer status** Printer is on line (not in the pause state).
No PE sensor detects that paper is loaded.
The release lever position is set to continuous paper.

Table 1-34 Paper Handling Sequence 1

Occurrence	Result
Print command sent	Continuous paper is loaded.
Pause button pressed	Printer enters pause state.
LF/FF button pressed	Continuous paper is loaded.
Load/Eject button pressed	Continuous paper is loaded.
Micro Adjust ↑ button pressed	No operation.
Micro Adjust ↓ button pressed	No operation.
Release lever set to Friction	The paper path is changed for cut sheets.

- **Printer status** The rear PE sensor detects that paper is loaded in the rear paper path.
The release lever is set to continuous paper.

Table 1-35 Paper Handling Sequence 2

Occurrence	Result
Pause button pressed	The printer goes off or on line.
LF/FF button pressed	The printer performs a line feed.
LF/FF button held down continuously	The printer performs a form feed after the line feed.
Load / Eject button pressed	Paper is ejected to the rear paper park position.
Load / Eject button pressed and paper advanced to skip area	Paper is advanced to the next TOF position.
Micro Adjust ↑ button pressed	The printer micro feeds paper forward.
Micro Adjust ↓ button pressed	The printer micro feeds paper backward.
Release lever set to Friction	The beeper sounds.
Front paper end sensor detects that paper is loaded in the front paper path.	The beeper sounds.

- **Printer status** The front PE sensor detects that paper is loaded in the front paper path.
The release lever is set to continuous paper

Table 1-36 Paper Handling Sequence 3

Occurrence	Result
PAUSE button pressed	Printer goes off or on line.
LF/FF button pressed	Printer performs a line feed.
LF/FF button held down continuously	The printer performs a form feed after the line feed.
Load / Eject button pressed	Paper is ejected to the front paper park position
Load /Eject button pressed and the paper was advanced to skip area	Paper is advanced to the next TOF position.
Micro Adjust ↑ button pressed	The printer micro feeds paper forward.
Micro Adjust ↓ button pressed	The printer micro feeds paper backward.
Release lever was set to Friction	The beeper sounds.
Front paper end sensor detects that paper was loaded in the rear paper path.	The beeper sounds.

- **Printer status** Printer is on line (not in the pause state).
No PE sensor detects that paper is loaded. (The printer is set to CSF .)
The release lever is set to the Friction.

Table 1-37 Paper Handling Sequence 4

Occurrence	Result
Print command sent	The paper is loaded from the CSF.
Pause button pressed	Printer goes off line.
LF/FF button pressed	Paper is loaded from the CSF.
Load / Eject button pressed	Paper is loaded from the CSF.
Micro Adjust ↑ button pressed	No operation.
Micro Adjust ↓ button pressed	No operation.
Release lever set to tractor position	The paper path is changed to tractor.
Rear/ Front paper end sensor detects that paper is loaded in the rear or front paper path. And, 3 seconds have passed.	The printer feeds paper.
Rear/ Front paper end sensor detects that paper is loaded in the rear or front paper path. And, Pause, LF/FF, or LOAD/EJECT button was pressed.	Ignored.

- **Printer status** The rear PE sensor detects that paper is loaded in the rear paper path.
Release lever position is set to Friction.

Table 1-38 Paper Handling Sequence 5

Occurrence	Result
Pause button pressed	Printer goes on or off line.
LF/FF button pressed	Printer performs a line feed.
LF/FF button held down continuously	Printer ejects paper forward after the line feed (except with roll paper). The printer performs a form feed after the line feed (roll paper).
LF / FF button pressed, and paper is advanced over the logical paper length.	Paper is ejected forward (except with roll paper). The printer performs a form feed (roll paper).
Load /Eject button pressed	Paper is ejected forward (except with roll paper). The printer performs a form feed (roll paper).
Micro Adjust ↑ button pressed	The printer micro feeds paper forward.
Micro Adjust ↓ button pressed	The printer micro feeds paper backward.
Release lever set to the tractor position	The beeper sounds.
Front paper end sensor detects that paper was loaded in the rear paper path.	The beeper sounds.

- **Printer status** Front PE sensor detects that paper is loaded in the rear paper path
The release lever position is set to Friction.

Table 1-39 Paper Handling Sequence 6

Trigger	Result
Pause button pressed	Printer goes on or off line.
LF/FF button pressed	Printer performs a line feed.
LF/FF button held down continuously	Paper is ejected forward after the line feed.
LF / FF button pressed, and paper advanced more than the logical paper length.	The paper is ejected forward.
Load /Eject button pressed	The paper is ejected forward.
Micro Adjust ↑ button pressed	The printer micro feeds paper forward.
Micro Adjust ↓ button pressed	The printer micro feeds paper backward.
Release lever set to tractor position	The beeper sounds.
Front paper end sensor detects that paper was loaded on the rear paper path.	The beeper sounds.

1.3.4. Paper Width (PW) Sensor Operation

The PW sensor is mounted on the ribbon mask holder to measure the paper width and detect the top edge of the paper. However, in cases where print data is over the paper width, the image cut function does not operate in all modes. This section describes when the image cut function is operational, as shown in the following table.

Table 1-40 PW Sensor Operation

Paper Path	Paper Width Measurement	Image Cut Function
Friction	Measured	Executed (Only Copy Mode 2)
Push Tractor (Rear / Front)	Measured	Not Executed ※ 1
Pull Tractor	Measured	Not Executed ※ 1

- ※ 1: The measured paper width value is used to estimate the printhead centering position. When narrow continuous paper (fewer than 30 columns) is loaded, the printer changes the centering position to the proper position, based on the measured paper width.

1.4 Operating Instructions

This section provides detailed information about the LQ-2170 control panel buttons and LEDs.

1.4.1 Control Panel Operations

The printer control panel contains 6 non-lock type push buttons and 10 LEDs for various printer functions. The exterior view of the control panel is shown in the following figure.

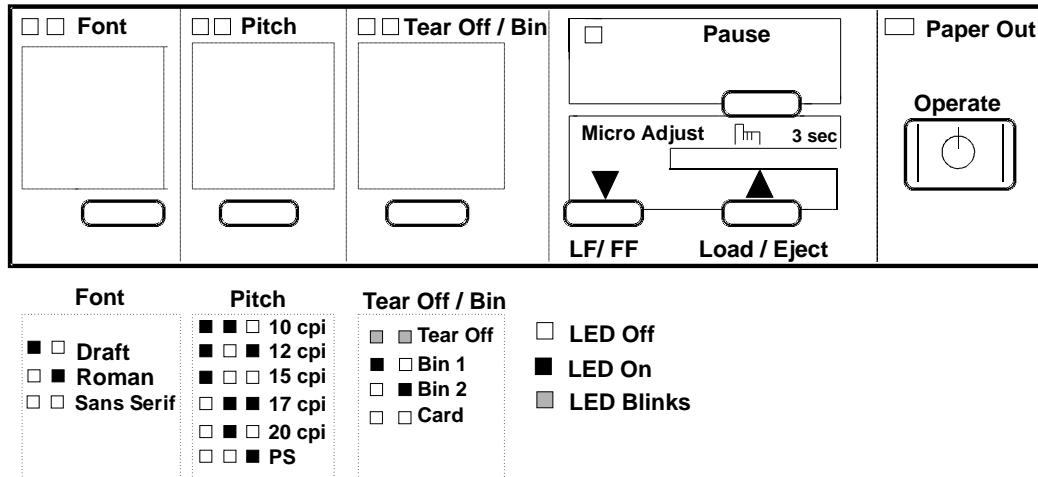

Figure 1-9 Control Panel

Operation in normal mode

In normal mode, pressing panel buttons executes following functions:

Table 1-41 Operation in Normal Mode

Buttons and Switches	Function
Operation	Turns the printer on and off.
Pause	Alternates printing and non-printing states. Enables the micro adjust function, when held down for 3 seconds.
Load / Eject	Loads or ejects paper Micro feeds forward, when that function is enabled.
LF / FF	Line feed, when pressed briefly. Form feeds, when held down for a few seconds. Micro feeds backward, when that function is enabled.
Tear Off / Bin	Advances continuous paper to the tear-off position. Selects CSF bin 1 / 2 or card mode.
Font	Selects font.
Pitch	Selects pitch.

Operations at power on

Turning the printer on while pressing panel buttons executes the functions below:

Table 1-42 Operation at Power On

Button	Function
Load / Eject	LQ self-test
LF / FF	Draft self-test
Load / Eject and LF / FF	Hexadecimal data dump
Pitch	Default setting
Font and Tear Off / Bin	Clear EEPROM
Pause	Bi-d adjustment
Others	Not available

Operation in default setting mode

The buttons used in default setting mode are as follows:

Table 1-43 Operation at Default Setting Mode

Button	Function
Pitch	Selects the menu.
Tear Off / Bin	Changes the setting
Others	Not available

1.4.2 Status Codes Indicated by the LEDs and Beeper

Table 1-44 Indicators and Beeper

	Pause	Paper Out	Tear Off / Bin	Pitch	Font	Beeper
Pause	On	—	—	—	—	—
Paper Out	On	On	—	—	—	○ ○ ○
Paper Jam	On	Blinks	—	—	—	● ● ● ● ●
Head Hot	Blinks	—	—	—	—	—
Cover Open	On	—	—	—	—	○ ○ ○
Micro Adjust	Blinks	—	—	—	—	○
Tear Off	—	—	—	—	—	○
Bin Selection	—	—	—	—	—	○
Pitch Selection	—	—	—	—	—	○
Font Selection	—	—	—	—	—	○
Fatal Error	Blinks	Blinks	Blinks	Blinks	Blinks	● ● ● ● ●

- indicates the beeper sounds for 100 ms with an interval of 100 ms.
- indicates the beeper sounds for 500 ms with an interval of 100 ms.
- indicates that the LED or beeper is not used to indicate this status condition.

1.4.3 Micro Adjust Function

The micro adjust function lets you set the TOF and tear off positions. After the printer is put in this mode, you can adjust the top of form (TOF) position up or down in increments of $\frac{1}{216}$ inch by pressing the LF/FF or Load/Eject button. The adjusted TOF position is saved to the EEPROM. If the printer is turned off, the setting is not cleared. The function is operational in the printer under the following conditions and within the following area:

Conditions required for the adjustment

The TOF position can be adjusted under the following conditions:

1. The data buffer is empty and the printer is on line.
2. Paper is at the TOF position.
3. The PAUSE button is held down more than 3 seconds to put the printer in micro adjust mode.

Adjustable area

Micro adjust positions can be set within the following range from the top edge of the page:

3 mm ~ 8.5 mm , 8.5 mm ~ 287.9 mm
(0.12" ~ 0.33" , 0.33" ~ 11.34")

1.4.4 Tear Off Function

The tear off function advances continuous paper to the tear off position when the Tear Off / Bin button is pressed. There are two modes for this function: auto tear off and manual tear off. The tear off mode can be selected in the default setting mode. After the paper is torn off at the perforation, it is fed back to the TOF position when any new print data is sent to the printer. The tear off position is saved in the EEPROM, and if the printer is turned off, the setting is not cleared.

Conditions required for the adjustment

※ Auto tear off function

- Auto tear off has been set to ON in default setting mode.
- The release lever has been set to Tractor.
- The data buffer is empty, and the printer is on line.
- More than 3 seconds have passed after the host computer finished transferring print data.

※ Manual tear off function

- Auto tear off has been set to OFF in default setting mode.**
- The release lever has been set to Tractor.**
- The data buffer is empty and the printer is on line, or the printer is off line.**
- The Tear Off button was pressed under all the conditions listed above.**

Paper handling with the tear off position

- Pressing the PAUSE button with the printer off line feeds the paper back to the TOF position for the next page and brings the printer back on line.
- Pressing the PAUSE button with the printer on line feeds the paper back to the TOF position for the next page and takes the printer off line.
- Pressing the LF / FF button feeds the paper back to the TOF position for the next page and executes a line feed.
- Pressing the Load / Eject button feeds the paper back to the TOF position for the next page and ejects paper backward.
- Pressing the PAUSE button more than 3 seconds puts the printer in micro adjust mode, where you can adjust the tear off position by pressing the LF / FF or Load / Eject button.
- If the printer is turned off while in the tear off mode, the tear off position is saved, and paper is fed back to the TOF position for the next page by turning on the printer, again.

1.4.5 Self-test Function

Pressing the Load / Eject button while turning on the printer puts the printer in LQ self-test mode. Pressing the LF/FF button while turning on the printer puts the printer in Draft self-test mode. You can stop the self-test temporarily by pressing the PAUSE button, and you can exit the self-test mode by turning off the printer. When pages are printed from the CSF, the first sheet is used for scaling the sheet length. Then, the maximum number of printable lines is printed as the bottom line of the sheet and this number is saved in non-volatile memory as the default page length. Page lengths are saved individually when a dual-bin CSF is in use.

The self-test prints out the following:

- The maximum number of printable lines (only on cut sheets from the CSF)
- The pattern of characters shown in the figure below.

```
Roman
!"#$%^()*+,-./0123456789:;<=>?@ABCDEFGHIJKLMN
OPQRSTUVWXYZ[\]^_`abcdefghijklmnopqr
!"#$%^()*+,-./0123456789:;<=>?@ABCDEFGHIJKLMN
OPQRSTUVWXYZ[\]^_`abcdefghijklmnopqr
!"#$%^()*+,-./0123456789:;<=>?@ABCDEFGHIJKLMN
OPQRSTUVWXYZ[\]^_`abcdefghijklmnopqr
!"#$%^()*+,-./0123456789:;<=>?@ABCDEFGHIJKLMN
OPQRSTUVWXYZ[\]^_`abcdefghijklmnopqrstu
vwx
!"#$%^()*+,-./0123456789:;<=>?@ABCDEFGHIJKLMN
OPQRSTUVWXYZ[\]^_`abcdefghijklmnopqrstu
vw
Sans serif
!"#$%^()*+,-./0123456789:;<=>?@ABCDEFGHIJKLMN
OPQRSTUVWXYZ[\]^_`abcdefghijklmnopqrstu
vwxyz
!"#$%^()*+,-./0123456789:;<=>?@ABCDEFGHIJKLMN
OPQRSTUVWXYZ[\]^_`abcdefghijklmnopqrstu
vwxyz
```

Figure 1-10 Self-test Printout

1.4.6. Hexadecimal Dump Function

Pressing the Load /Eject and LF/FF buttons while turning on the printer puts the printer in hexadecimal dump mode. In this mode, data received is printed out in hexadecimal format, along with the corresponding ASCII characters. The function is useful to check data received from the host. If a received code is not a printable ASCII character, the printer prints a period (.) in the ASCII column. When received data remains in the buffer, that data is printed by pressing the PAUSE button.

```
Hex Dump
1B 40 1B 28 47 01 00 01 1B 28 55 01 00 0A 1B 55   ..@.(G....(U....U
01 1B 28 43 02 00 70 10 1B 28 63 04 00 3C 00 70   ..(C..p..(c..<.p
10 1B 2B 30 1B 2E 01 14 14 1B C0 05 B1 00 B1 00   ..+O.....L.....
81 00 81 00 81 00 81 00 81 00 81 00 81 00 81 00   .....
81 00 81 00 81 00 81 00 81 00 81 00 81 00 81 00   .....
81 00 81 00 81 00 81 00 81 00 81 00 81 00 81 00   .....
81 00 81 00 91 00 03 0F F8 03 80 F6 00 02 E0 00   .....°...#...α.
E0 FA 00 02 70 00 3C FB 00 02 E0 01 C0 C3 00 0E   α'..p.<°..α.Lf..
07 FF FB 03 00 03 F0 00 01 FF F0 F0 00 07 F0 F0   ° f f f f f f f f
```

Figure 1-11 Hexadecimal Printout

1.4.7 Default Setting Function

Pressing the Pitch button while turning on the printer puts the printer in default setting mode. Some default printer settings can be changed in this operation. The method for setting defaults is described in the instruction sheets, which are printed out immediately after you enter the mode. You are asked to use three buttons (Font, Pitch, and Tear Off / Bin) and watch six LEDs (Pitch: 3 LEDs, Tear Off/Bin: 2 LEDs, and Pause: 1 LED) on the control panel. Refer the instructions printed in default setting mode for the actual method used to set defaults.

1.4.8 EEPROM Clear Function

Pressing the Font and Tear Off / Bin buttons while turning on the printer resets the EEPROM to the standard factory settings. This operation initializes the items below to the factory settings in the right-hand column.

Table 1-45 EEPROM Initialization Settings

Setting	Factory Default
Font	Roman
Pitch	10 CPI
Character Table	PC437
Other Font Selection	Roman-T
Page Format (Tractor Rear / Front)	Page Length: 11 inches TOF Position: 8.5 mm (0.333 inches) Bottom Margin : 11 inches
Page Format (Friction , CSF Bin 1 / Bin 2 , Manual Feed Rear / Front)	Page Length: 22 inch TOF Position: 8.5 mm (0.333 inch) Bottom Margin: 22 inches
Print Direction	Bi-d
Auto LF	Off
Auto Tear-Off	Off
1-inch Skip	Off
High Speed Draft	On
Input Buffer	On
BDC-ST Reply	On
Roll Paper	Off
I/F Selection	Auto I/F Mode
Auto I/F Wait Time	10 sec.
Software	ESC/P2
Slashed Zero	Off
Buzzer	On
A.G.M (IBM Mode)	Off
Auto CR (IBM Mode)	Off
Adjust Tear-Off Position	0 inch
Paper Conditions	Friction: Bin 1 , Tractor: Tear-Off: Status Off

1.4.9 Bidirectional Adjustment Function

Pressing the **PCUSE** button while turning on the printer puts the printer in bidirectional adjustment mode. In this mode, you can adjust the bidirectional alignment for the following three modes:

1. High-speed draft mode
2. Draft mode
3. LQ mode

For instructions on performing the adjustment, see Chapter 4.

1.5 Initialization

1.5.1 Software Initialization

This initialization is activated by the control code **ESC@**. This initialization:

- Clears unprinted data.
- Resets the printer's setting defaults.

1.5.2 Operation Initialization

This initialization is activated by receipt of the $\overline{\text{INIT}}$ signal (negative pulse). This initialization:

- Clears the buffer of all data.
- Cancels download character definition.
- Puts the printer in standby state, if no errors occur.
- Executes software initialization.

1.5.3 Power On Initialization

This initialization is activated by power on or by a cold-reset command (remote **RS** command). This initialization

- Initializes the printer mechanism.
- Executes operation initialization.

1.6 MAIN COMPONENTS

The main components of the LQ-2170 are designed for easy removal and repair. The main components are:

The

- C165 MAIN Board Assembly
- C165 PSB/PSE Board Assembly (120 V/230 V)
- C165 PNL Board Assembly
- Printer Mechanism
- Housing Assembly

The following figure shows the main components of the LQ-2170.

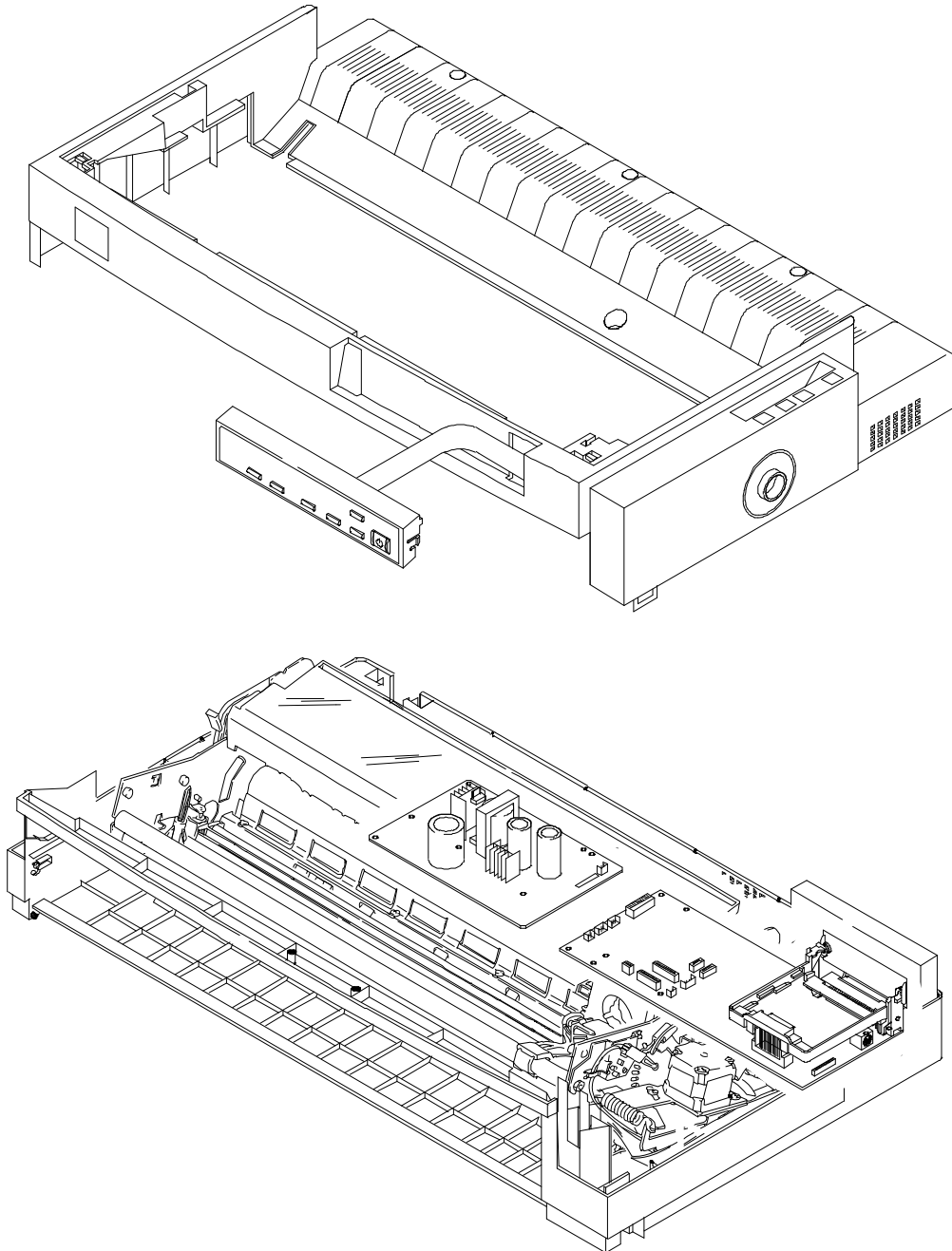

Figure 1-12 Main Components

1.6.1 C165 MAIN Board Assembly

The C165 MAIN board consists of a TMP96C141AF CPU, an E05B13 gate array, a program/CG ROM, a PS-RAM, an EEPROM, etc.

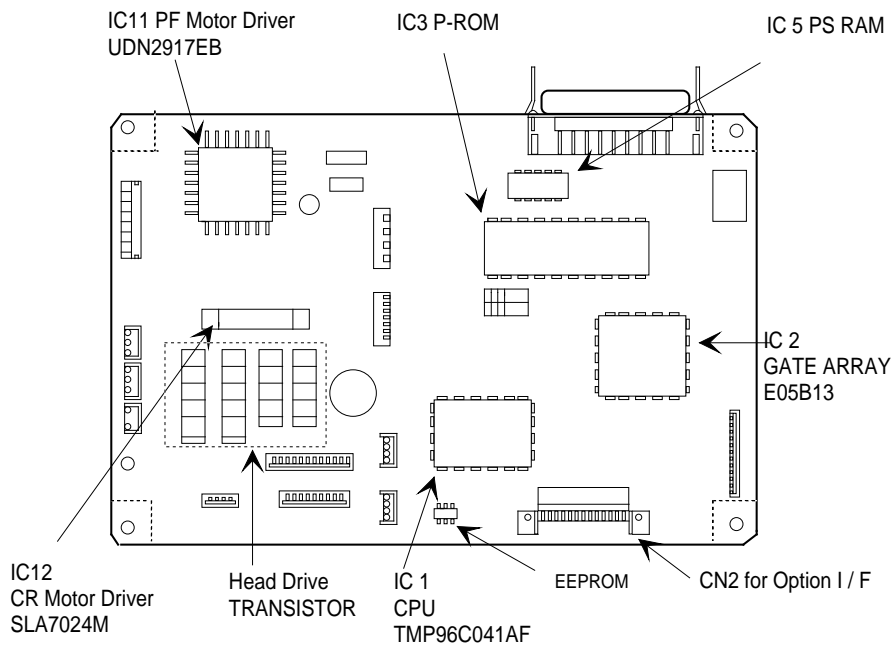

Figure 1-13 C165 MAIN Board Assembly

1.6.2 C165 PSB/PSE Board Assembly

These boards have two AC input voltage ratings: 120 VAC (C165 PSB) and 230 VAC (C165 PSE). Both boards consist of a transformer, switching FET, regulator IC, diode bridge, etc. The power supply board provides +5 VDC and +35 VDC for the main board and printer mechanism.

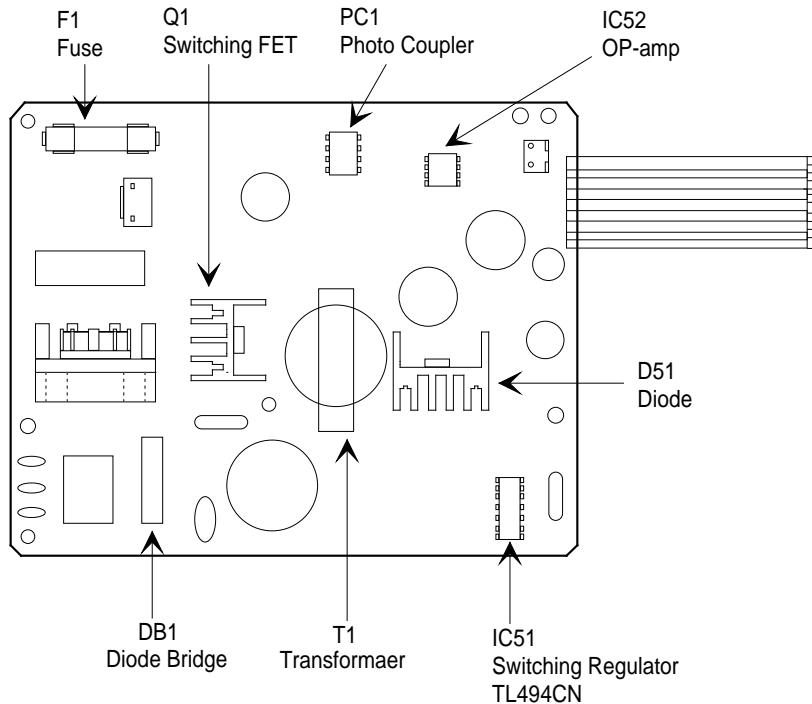

Figure 1-14 C165 PSB/PSE Board Assembly

1.6.3 C165 PNL Board Assembly

This board function is the control panel for the LQ-2170. It consists of a power switch, six buttons, and 10 indicator LEDs. This board is almost same as it for the LQ-2170.

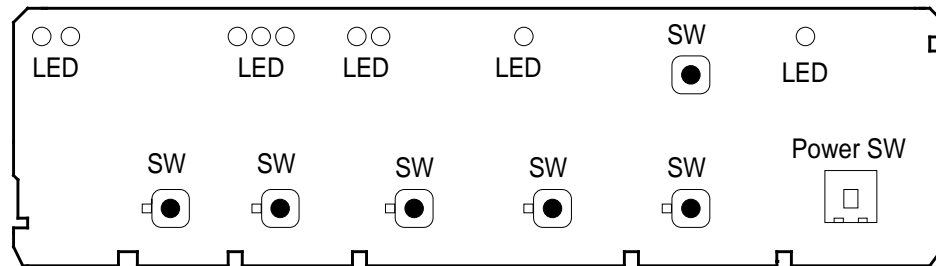

Figure 1-15 Board Assembly C165 PNL

1.6.4 Printer Mechanism

The printer mechanism consists of an 24-pin impact dot head, paper feed (PF) motor, ribbon feed (RF) motor, paper end (PE) sensor, home position (HP) sensor, platen gap (PG) sensor, release lever sensor, etc.

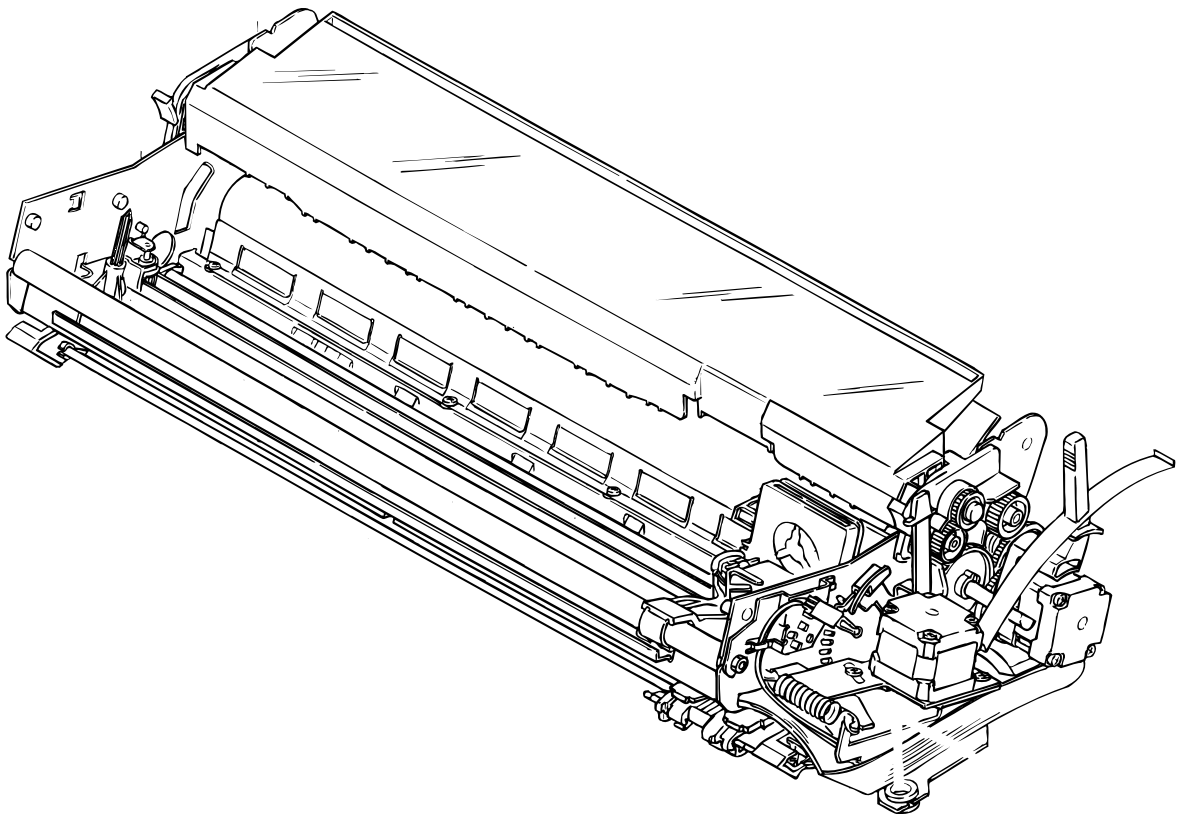

Figure 1-16 Printer Mechanism

1.6.5. Housing Assembly

This consists of printer cover assembly, edge guide assembly, upper housing, lower housing assembly, etc.

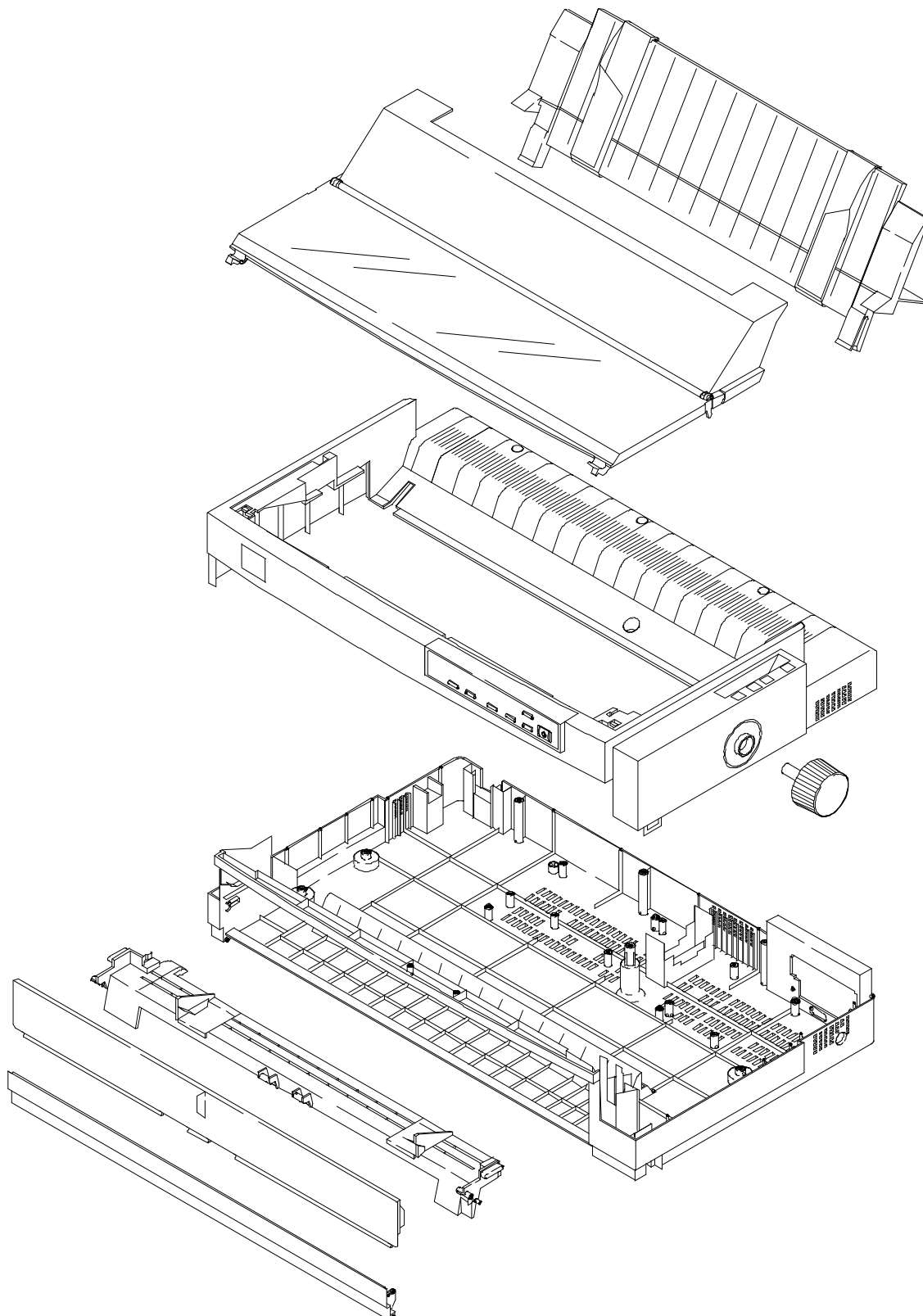

Figure 1-17 Housing Assembly

CHAPTER 2 Operating Principles

Table of Contents

2.1 PRINTER MECHANISM OPERATION	2-1
2.1.1 Printing Mechanism	2-1
2.1.2 Carriage Movement Mechanism	2-2
2.1.3. Platen Gap Adjustment	2-3
2.1.4 Paper Handling Mechanism	2-4
2.1.4.1 Release Lever.	2-4
2.1.4.2 Paper Advance Mechanism	2-5
2.1.5 Paper Paths	2-11
2.1.6 Ribbon Advance Mechanism	2-16
2.2 POWER SUPPLY OPERATION	2-17
2.2.1 Power Supply Overview	2-17
2.2.2 Power Supply Circuit Operation	2-18
2.3 CONTROL CIRCUIT	2-22
2.3.1 Control Circuit Operation Overview	2-22
2.3.2 System Reset Circuit	2-24
2.3.3 Printhead Drive Circuit	2-24
2.3.4 CR Motor Drive Circuit	2-25
2.3.5 PF Motor Drive Circuit	2-26
2.3.6 EEPROM Control Circuit	2-26
2.3.7 Sensor Circuits	2-27

List of Figures

Figure 2-1. Printhead Operation	2-1
Figure 2-2. Carriage Movement Mechanism.	2-2
Figure 2-3. Platen Gap Adjust Lever.	2-3
Figure 2-4. Release Switch	2-4
Figure 2-5. Friction Advance Operation Using the Top Entrance	2-5
Figure 2-6. Push Tractor Operation Using the Rear Paper Entrance	2-6
Figure 2-7. Push Tractor Operation Using the Front Paper Entrance.	2-7
Figure 2-8. Pull Tractor Operation Using the Bottom Paper Entrance	2-8
Figure 2-9. Push- Pull Tractor Operation Using the Rear Paper Entrance.	2-9
Figure 2-10. Push- Pull Tractor Operation Using the Front Paper Entrance	2-10
Figure 2-11. Paper Path and Detector PE Sensor Location	2-11
Figure 2-12. Friction Feeding Using the Top Entrance	2-11
Figure 2-13. Push Tractor Feeding Using the Rear Entrance.	2-12
Figure 2-14. Pull Tractor Feeding Using the Rear Entrance.	2-12
Figure 2-15. Push-Pull Tractor Feeding Using the Rear Entrance	2-13
Figure 2-16. Pull Tractor Feeding Using the Bottom Entrance	2-13
Figure 2-17. Friction Feeding Using the Front Entrance.	2-14
Figure 2-18. Push Tractor Feeding Using the Front Entrance	2-14
Figure 2-19. Pull Tractor Feeding Using the Front Entrance	2-15
Figure 2-20. Push-Pull Tractor Feeding Using the Front Entrance.	2-15
Figure 2-21. Ribbon Advance Mechanism	2-16
Figure 2-22. Power Supply Circuit Block Diagram	2-17
Figure 2-23. Power Switch Circuit.	2-18
Figure 2-24. Over Voltage Protection Circuit	2-18
Figure 2-25. +35V Line Constant Voltage Control Circuit.	2-19
Figure 2-26. +35V Line Overload Detector Circuit	2-19
Figure 2-27. +35V Line Over Current Protection Circuit	2-20
Figure 2-28. +5V Line Over Current Protection Circuit	2-20
Figure 2-29. +5V Constant Voltage Control Circuit.	2-21
Figure 2-30. Control Circuit Block Diagram.	2-22
Figure 2-31. Data Flow	2-23
Figure 2-32. Reset Circuit	2-24
Figure 2-33. Reset Signal Output Timing	2-24
Figure 2-34. Printhead Drive Circuit	2-24
Figure 2-35. CR Drive Circuit	2-25
Figure 2-36. PF Motor Drive Circuit.	2-26
Figure 2-37. EEPROM Control Circuit.	2-26
Figure 2-38. Sensor Circuit	2-27

List of Tables

Table 2-1. CR Motor Assembly Specifications	2-2
Table 2-2. Platen Gap and Print Speed	2-3
Table 2-3. Release Lever Position	2-4
Table 2-4. Ribbon Advance Gear Linkage	2-16
Table 2-5. Power Supply Board	2-17
Table 2-6. Power Supply Output Voltage and Applications	2-17
Table 2-7. Functions of the Main IC	2-23
Table 2-8. CR Motor Drive Mode	2-25

2.1 PRINTER MECHANISM OPERATION

This section describes the printer mechanism and explains how it works.

2.1.1 Printing Mechanism

The printing mechanism is composed of the printhead, ink ribbon, and ribbon mask. The printhead is an 24-pin (12 pins \times 2) head for impact dot printing. To improve the durability of the dot wires, they are arranged on the printhead in 2 columns.

Each wire has its own drive coil, which causes the wire to move in and out of the printhead to print each dot. The four steps below describe how these driving wires work.

1. A drive signal, transmitted from the control circuit to the printhead drive circuit, is converted to the proper printhead driving voltage, which energizes a corresponding coil. The energized coil then causes the iron core to become magnetized.
2. The magnetic force draws the actuating plate toward the core, and the dot wire, which is connected to the core, rushes toward the platen.
3. When the dot wire impacts the platen, pressing against the ribbon and paper, it prints a dot.
4. When the driving voltage stops energizing the coil, the magnetic force from the iron core vanishes. The actuating plate returns to its original position (the position before coil was energized) with spring action. The dot wire also returns to its original position.

This is the sequence used to print a single dot.

The mechanism is equipped with a built-in thermistor for head temperature detection. The temperature detected by the thermistor is converted to an electric signal and fed back to the control circuit.

The printhead is also used as a beeper. Head driving coils move all the dot wires back and forth at a frequency of 1.98 KHz for 65 ± 5 μ sec without impacting the platen, so that the wires vibrate. The vibrating dot wires create the sound used for beep codes.

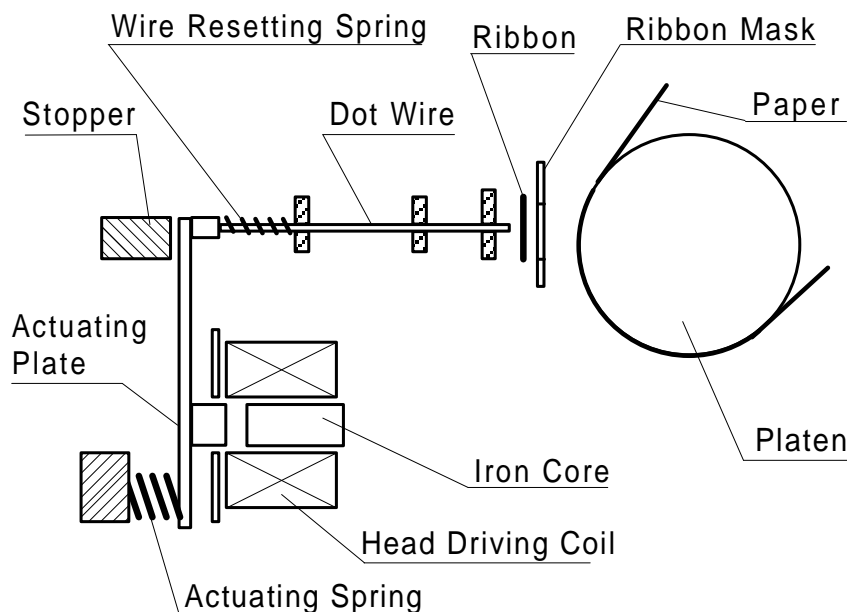

Figure 2-1 Printhead Operation Principles

2.1.2 Carriage Movement Mechanism

The carriage movement mechanism consists of the carriage assembly, carriage (CR) motor, timing belt, driven pulley, home position (HP) sensor, etc. The CR motor drives the timing belt. The carriage assembly is connected to the timing belt, which is moved by the CR motor. Figure 2-2 shows the carriage movement mechanism.

The printer detects the carriage home position with the HP sensor. This sensor is the basis for determining the carriage position. The HP sensor informs the CPU when the carriage is at the home position. The sensor is ON, when the carriage is pushed to the right or left. The striker on the carriage activates the sensor to indicate the carriage is at the home position, which toggles the sensor to OFF.

Table 2-1. CR Motor Assembly Specifications

Category	Requirement
Type	4-phase, 200-pole, HB-type pulse motor
Drive Voltage	35 ± 2.1 VDC
Coil Resistance	2.7 Ω ± 10%, per phase, at 25° C (77° F)
Inductance	3.7 μH ± 20% (per phase, at 1K Hz 1 V rms)

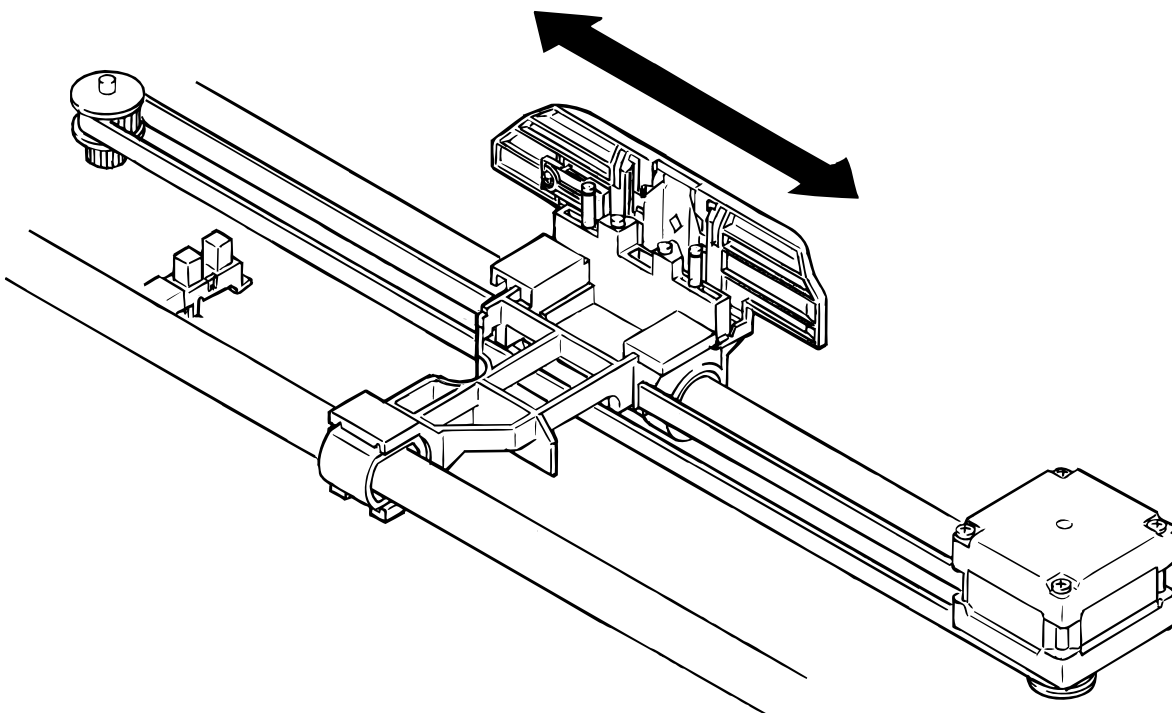

Figure 2-2 Carriage Movement Mechanism

2.1.3 Platen Gap Adjustment

You can adjust the platen gap (the gap between the platen and printhead) to allow the printer to use paper of different weights or thicknesses. When you move the platen gap adjust lever forward or backward, the carriage guide shaft rotates. This rotation moves the carriage either toward or away from the platen and changes the platen gap. This adjustment function has nine ranges for the adjustment, and the adjustment position is detected by platen gap (PG) switches.

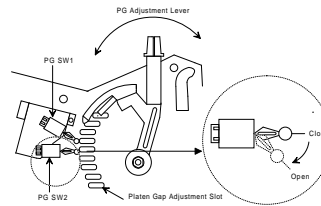

Figure 2-3 Platen Gap Adjustment Lever

Moving the platen gap adjust lever beyond position 2 changes the print speed mode to Copy mode, and the speed slows down to about $\frac{2}{3}$ normal to protect the printhead. The following table show you the relationship between the platen gap and the print speed.

Table 2-2. Platen Gap and Print Speed

Paper Type	Paper Thickness (mm)	Adjust Lever Position	PG SW	Print Speed
Single Sheet	0.065	0	Closed	Normal
	0.1	0	Closed	Normal
	0.14	1	Closed	Normal
Continuous Paper (Single Sheet)	0.065	0	Closed	Normal
	0.09	0	Closed	Normal
Continuous Paper (Multipart)	~0.18	1	Closed	Normal
	~0.25	2	Open	Copy
	~0.32	3	Open	Copy
	~0.39	5	Open	Copy
Labels	0.07 / 0.19	2	Open	Copy
Envelopes	0.16 / 0.32	2	Open	Copy
	0.16 / 0.40	3	Open	Copy
	0.22 / 0.44	4	Open	Copy
	0.23 / 0.46	4	Open	Copy
	0.26 / 0.52	6	Open	Copy
Card Stock	0.22	2	Open	Copy

2.1.4. Paper Handling Mechanisms

During the normal operation, paper is fed to the printer, advanced to the specified position, and ejected from the printer. These paper-handling operations are performed by various paper handling mechanisms, such as tractors, platens, rollers, and gears. This section describes the printer's paper handling mechanisms.

2.1.4.1. Release Lever

The release lever is used to select friction for rear /front tractor feed or to release the paper for pull tractor feed. Changing the release lever position moves the paper guide rollers, and the new lever position is detected by 2 release switch sensors (RLSW1 and RLSW2). See the following table.

Table 2-3. Release Lever Position

Release Lever Position	Status of Paper Guide Rollers	RL SW 1	RL SW 2
Friction mode	The paper guide rollers are pressed against the platen	Open	Open
Front push tractor mode	The paper guide rollers are separated from the platen	Closed	Open
Rear push tractor mode	The paper guide rollers are separated from the platen	Closed	Open
Pull tractor mode	The paper guide rollers and the rollers for the lower paper guide are separated from each position.	Closed	Closed

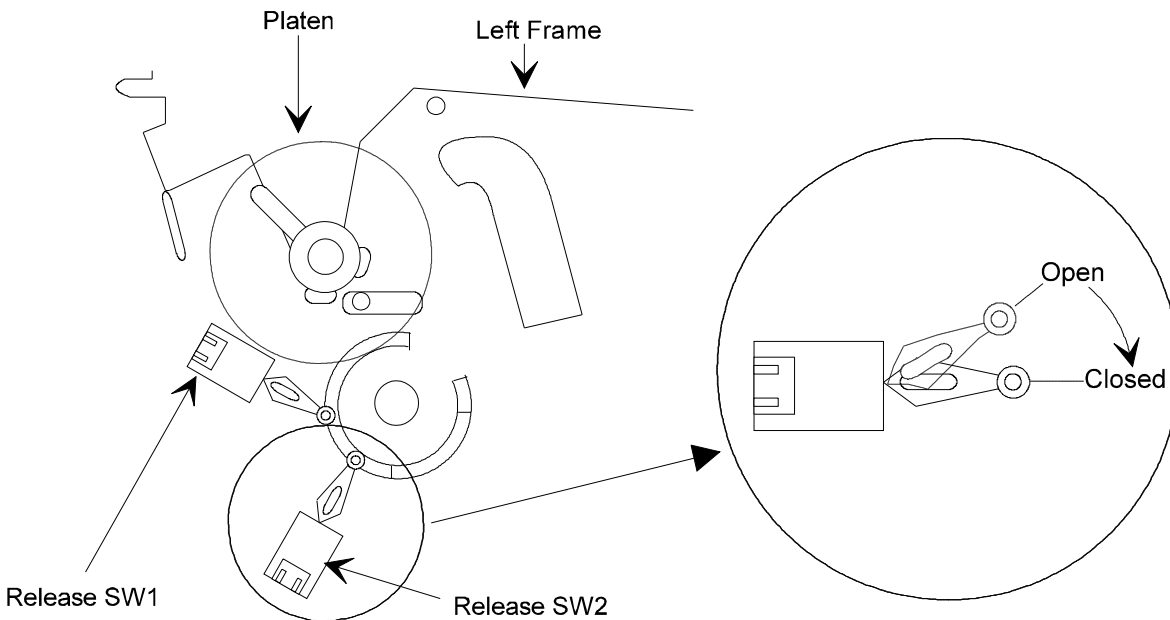

Figure 2-4 Release Switch

2.1.4.2. Paper Advance Mechanism

This section describes how the friction and tractor advance mechanisms work to move the paper through the printer.

1. Friction Advance Method

Paper is held between the platen and the paper guide rollers and between the paper tension roller and paper tension unit cover. The paper feed (PF) motor pinion gear, turns in the direction of the black arrow, driving the paper advance reduction gear. The paper advance reduction gear turns the platen gear and paper tension roller gear. Paper advances in the direction of the white arrow. Figure 2-5 shows the friction advance method when paper is fed through the top paper entrance.

In the friction advance method, the paper guide roller spring holds the paper against the platen. Paper can be released by setting the release lever to the tractor feed position.

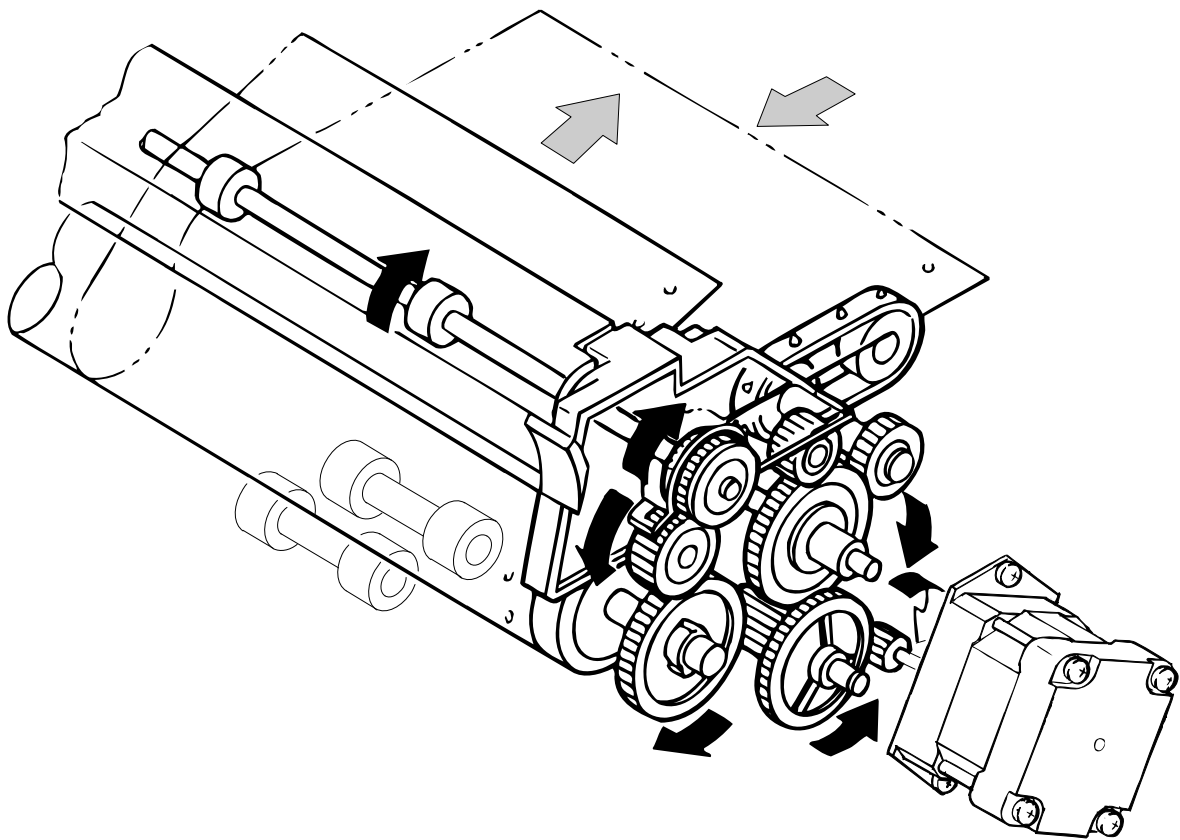

Figure 2-5 Friction Advance Operation Using the Top Entrance

2. Push Tractor Method

The push tractor method is used with the rear or front entrance.

When the push tractor method is used with the rear entrance, the torque generated by the PF motor is transmitted to the push tractor gear through the PF motor pinion gear, paper advance reduction gear, and tractor reduction gear. When the PF motor pinion gear turns in the direction of the black arrow, the tractor gear rotates in the direction of the black arrow, and thus feeds paper into the printer. Paper is advanced by the platen and paper tension roller, which are also driven by the PF motor through the gear train.

When the push tractor method is used with the front entrance, the torque generated by the PF motor is transmitted to the push tractor gear through the PF motor pinion gear, paper advance reduction gear, platen gear, and gear train in the front part of the printer. When the PF motor pinion gear turns in the direction of the black arrow, the tractor gear rotates in the direction of the black arrow and thus feeds paper into the printer. Paper is advanced by the paper drive roller and platen, which are also driven by the PF motor through the gear train.

In the push tractor method, the release lever is set to one of the tractor positions to release the pressure between the paper guide roller and the platen. Figure 2-6 illustrates push tractor operation when paper is fed through the rear paper entrance. Figure 2-7 illustrates push tractor operation when the paper is fed through the front paper entrance.

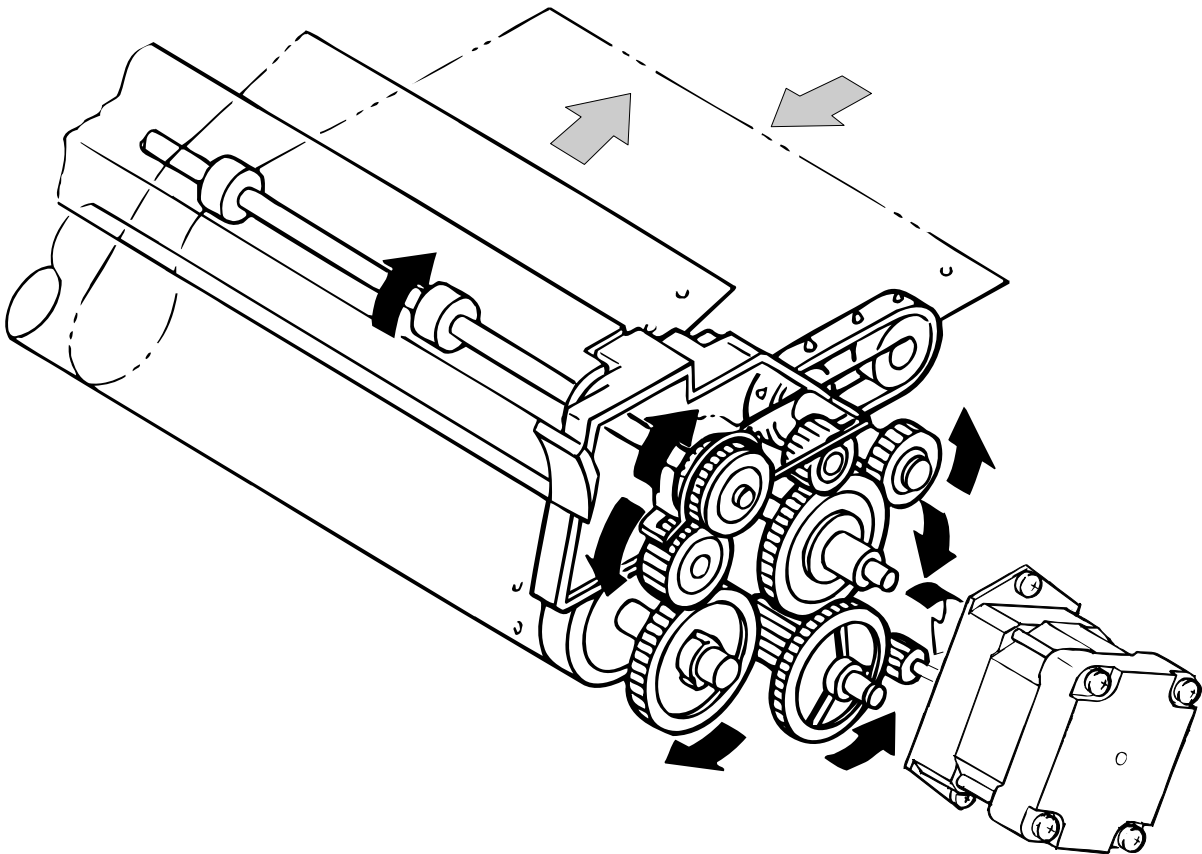

Figure 2-6 Push Tractor Operation Using the Rear Paper Entrance

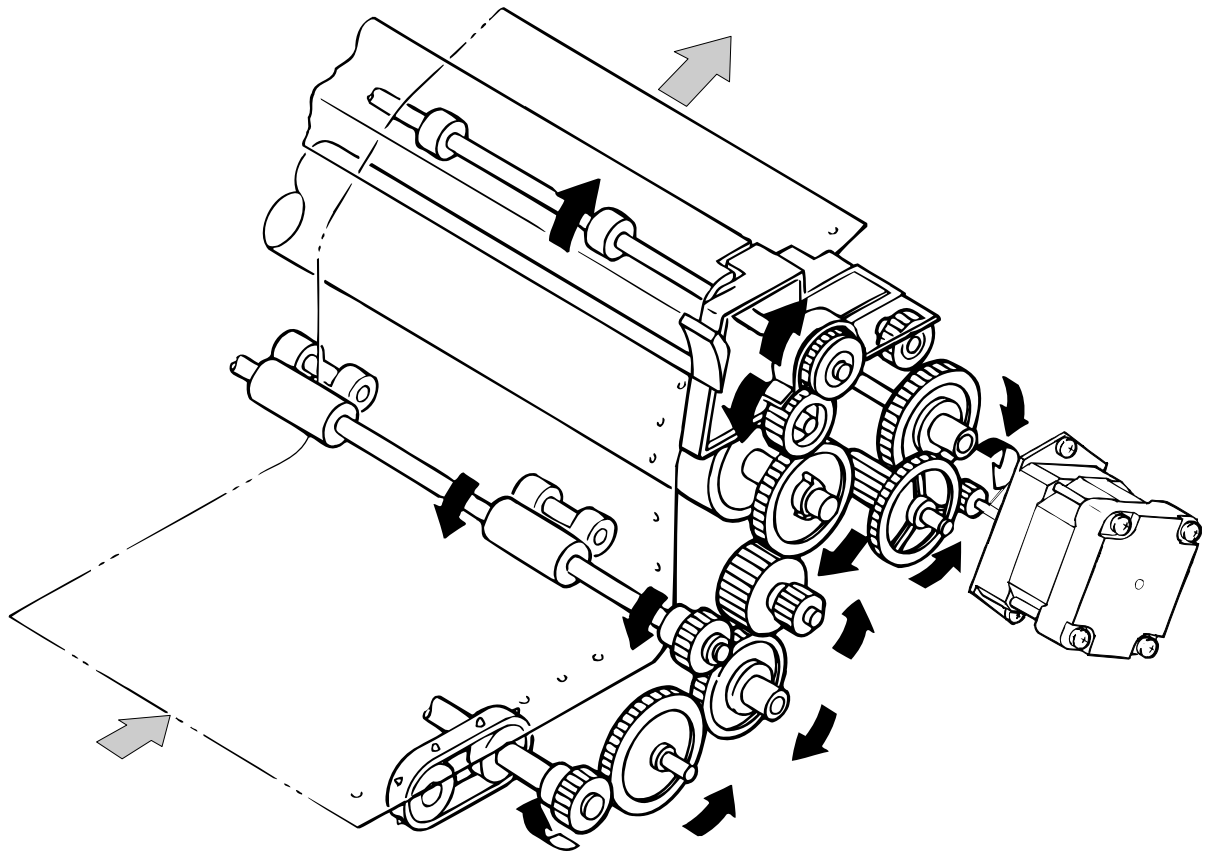
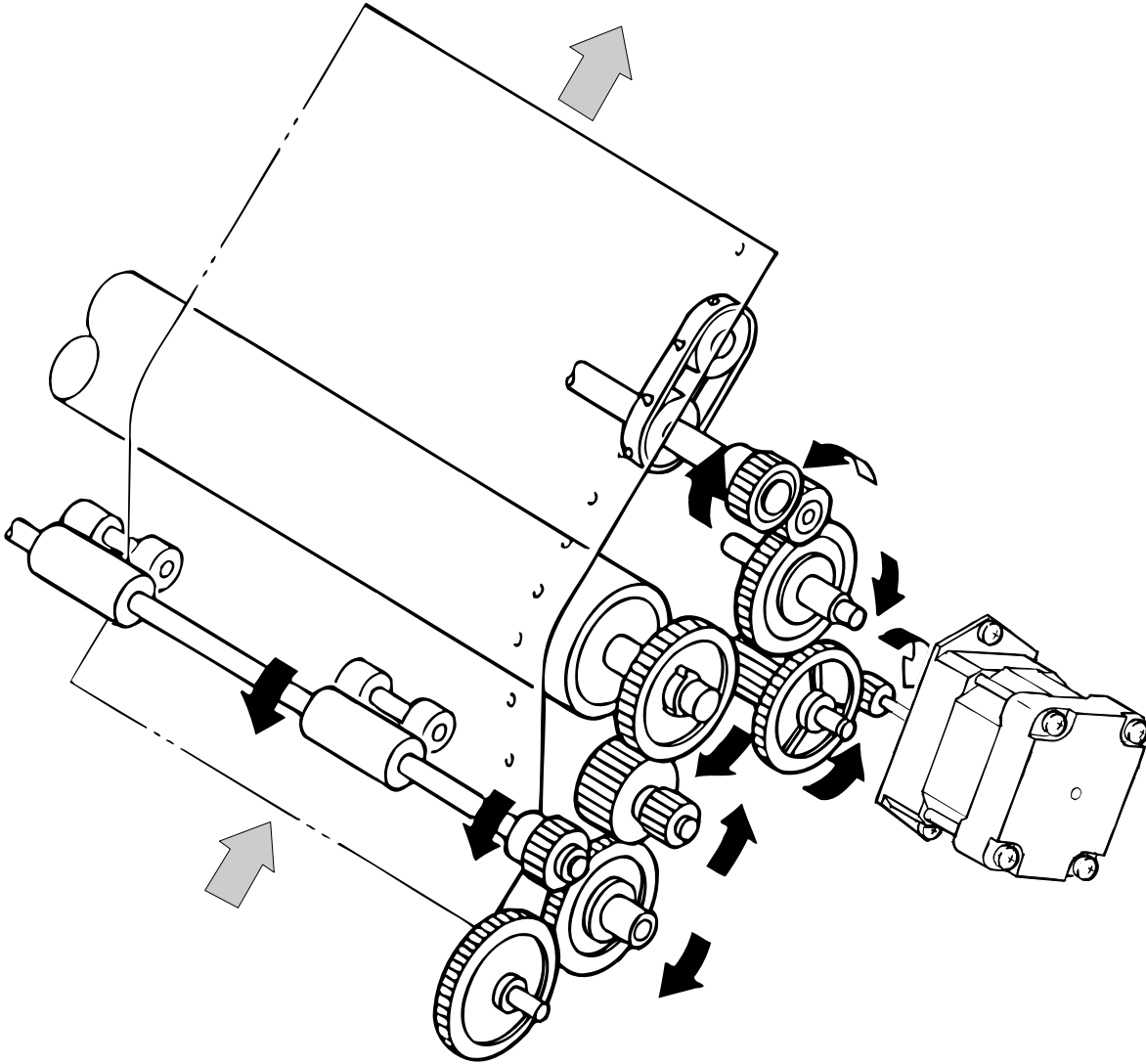

Figure 2-7. Push Tractor Operation Using the Front Paper Entrance

3. Pull Tractor Method

The pull tractor advances paper in basically the same way as the push tractor. The push tractor is installed at the paper entrance and pushes paper into the printer. On the other hand, the pull tractor is installed at the paper exit and pulls paper out of the printer mechanism. As a result, the paper tension unit is not required. Figure 2-8 illustrates pull tractor operation when paper is fed through the bottom paper entrance.

Figure 2-8 Pull Tractor Operation Using the Bottom Paper Entrance



4. Push-Pull Tractor Method

The push-pull tractor method is a combination of the push and pull tractor methods. Two tractors are used to advance the paper: one at the front paper entrance and the other at the rear paper entrance. They operate simultaneously to push and pull the paper through the printer mechanism. Figure 2-9 illustrates push-pull tractor operation when paper is fed through the rear paper entrance. Figure 2-10 illustrate push-pull tractor operation when paper is fed through the front entrance.

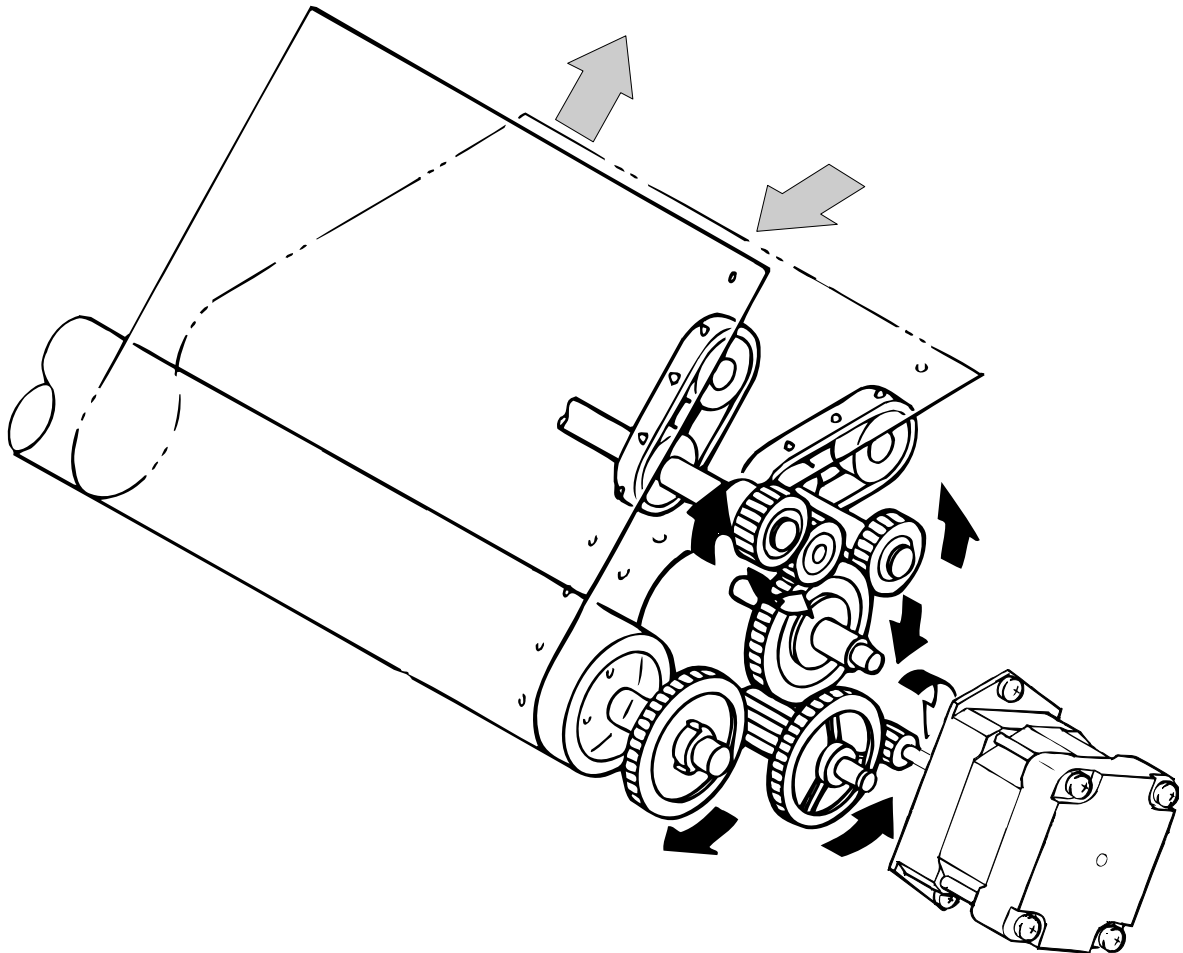

Figure. 2-9 Push-Pull Tractor Operation Using the Rear Paper Entrance

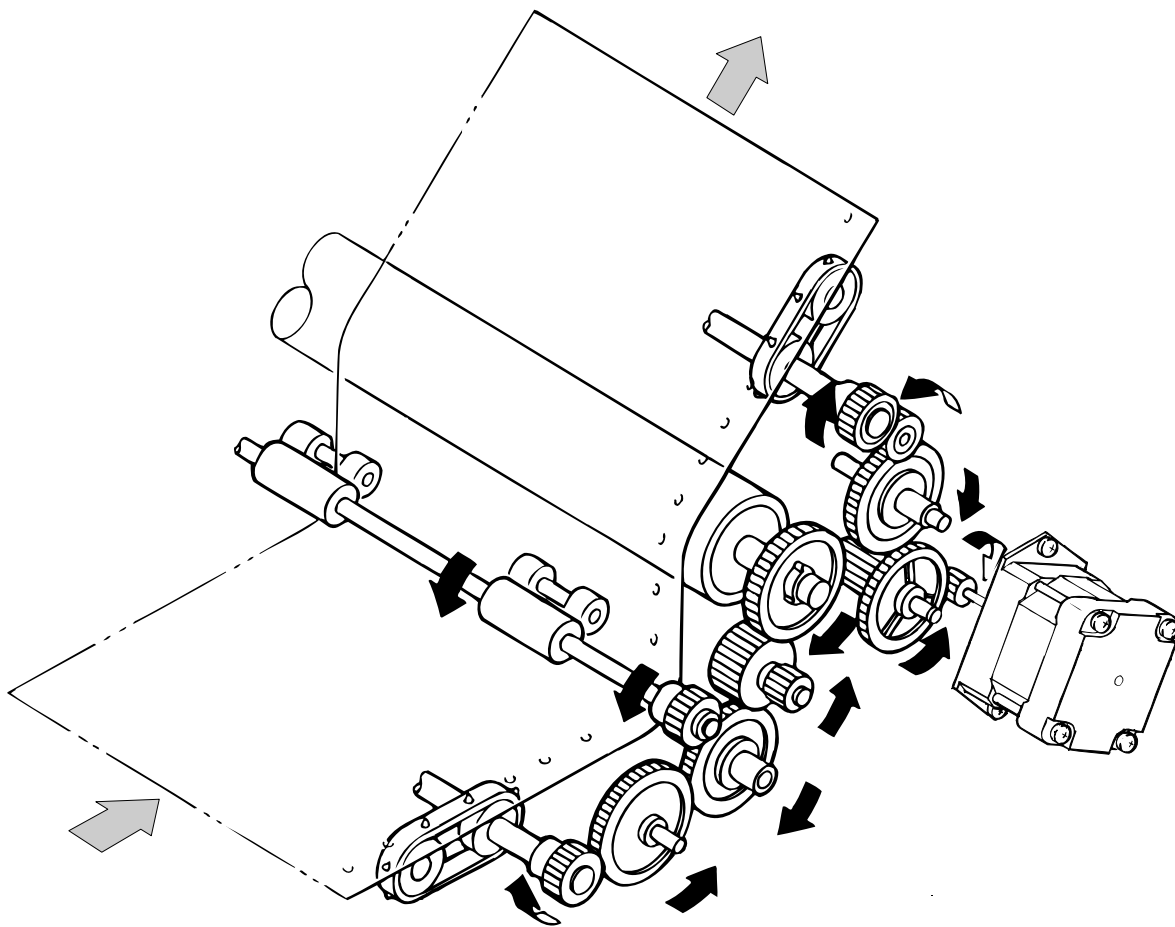

Figure 2-10 Push-Pull Tractor Operation Using the Front Paper Entrance

2.1.5 Paper Paths

This section describes various paper paths through the printer mechanism. These paper paths are divided into four groups, depending on which entrance (top, rear, bottom, or front) is used to feed paper. The printer has two PE (paper end) sensors. The front PE sensor is located in front of the printer mechanism. The rear PE sensor is located behind the printer mechanism. Refer to the following figure.

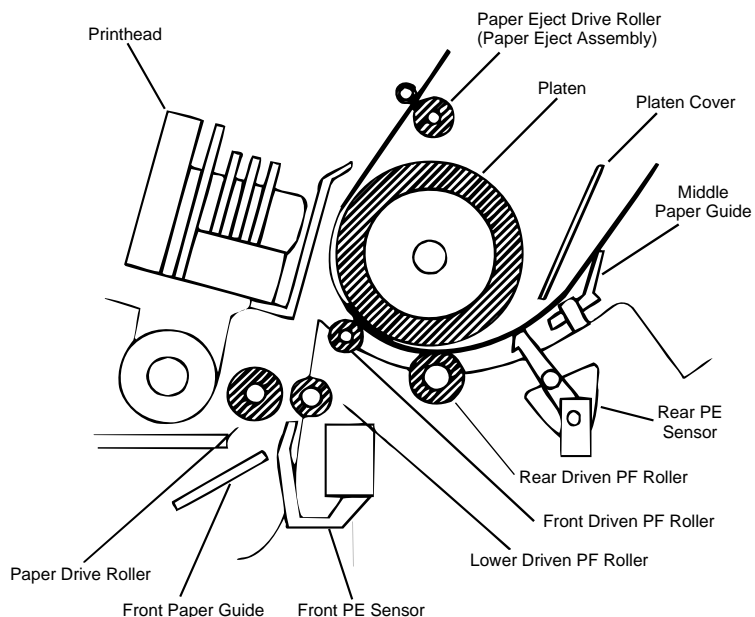
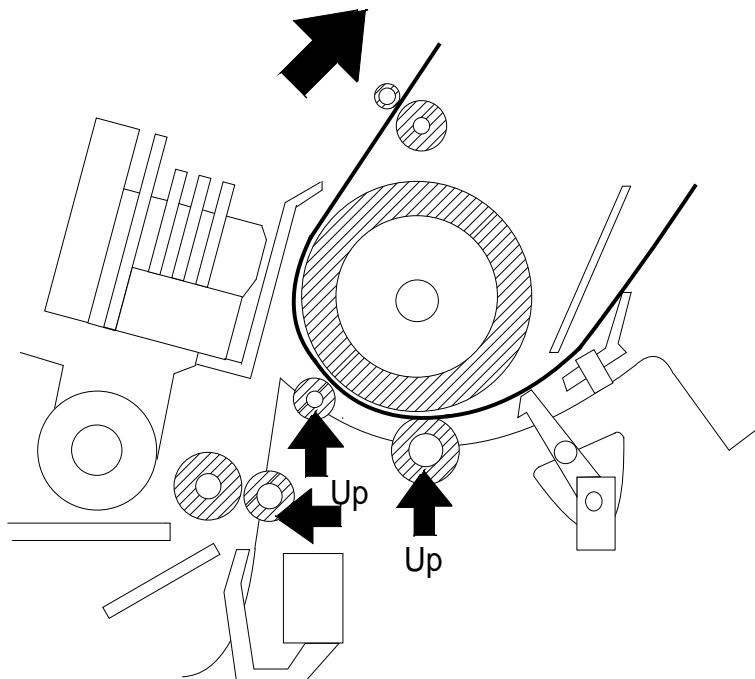

Figure 2-11. Paper Paths and PE Sensor Locations

1. Top Entrance

Figure 2-12 shows the paper path for friction feed using the top entrance. The top entrance is only used with the friction feed method. When the top entrance is used, the rear PE sensor detects when the paper is out.

Figure. 2-12. Friction Feeding Using the Top Entrance



2. Rear Entrance

Figures 2-13, 2-14, and 2-15 show the paper paths for tractor feeding using the rear entrance. You can use the rear entrance with any of the following paper feed methods: push tractor feed, pull tractor feed, or push-pull tractor feed. When you use the rear entrance, the rear PE sensor detects when paper is out.

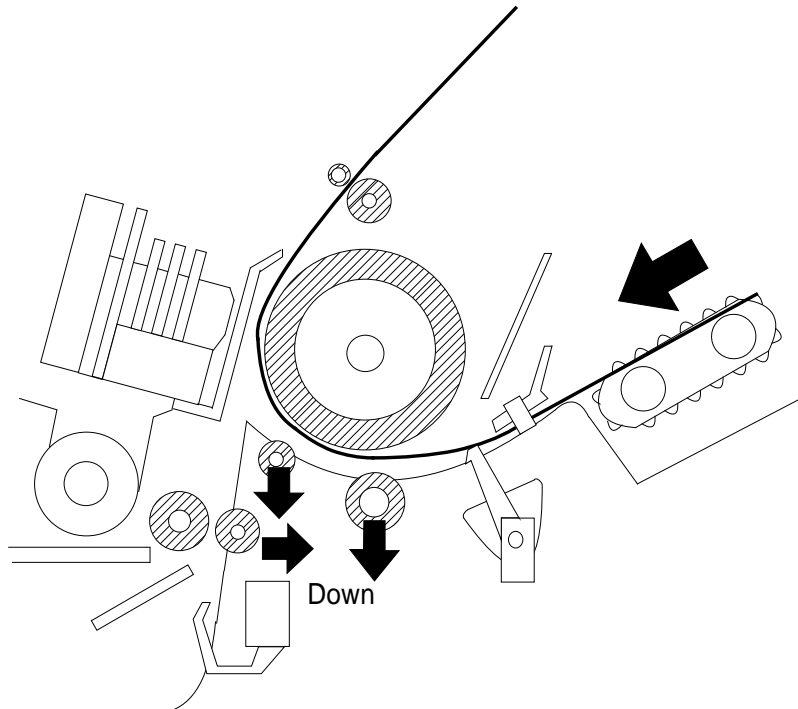

Figure. 2-13. Push Tractor Feeding Using the Rear Entrance

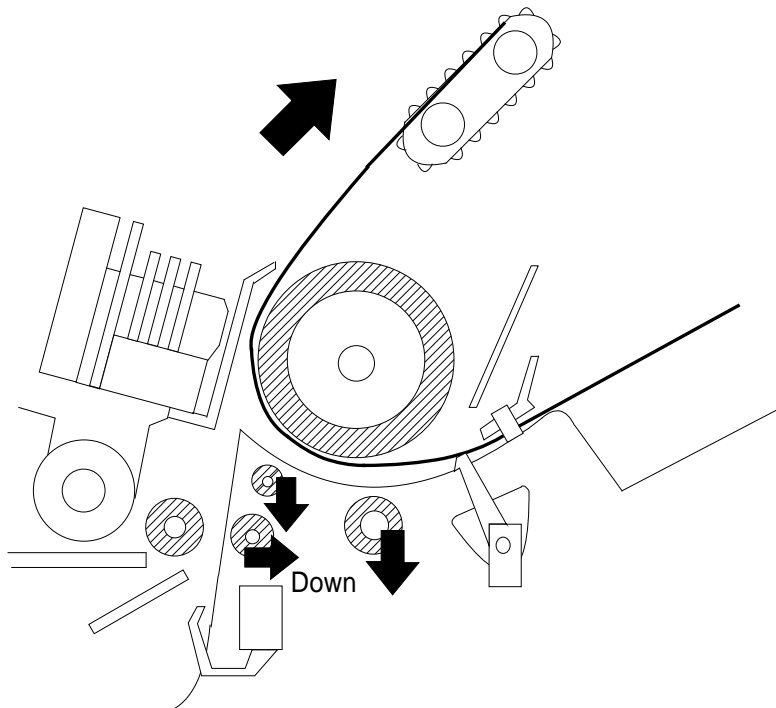

Figure. 2-14. Pull Tractor Feeding Using the Rear Entrance

As shown above in Figure 2-14, when you use the pull tractor in this printer, you must remove the paper eject cover, which includes the paper tension roller, from the printer mechanism.

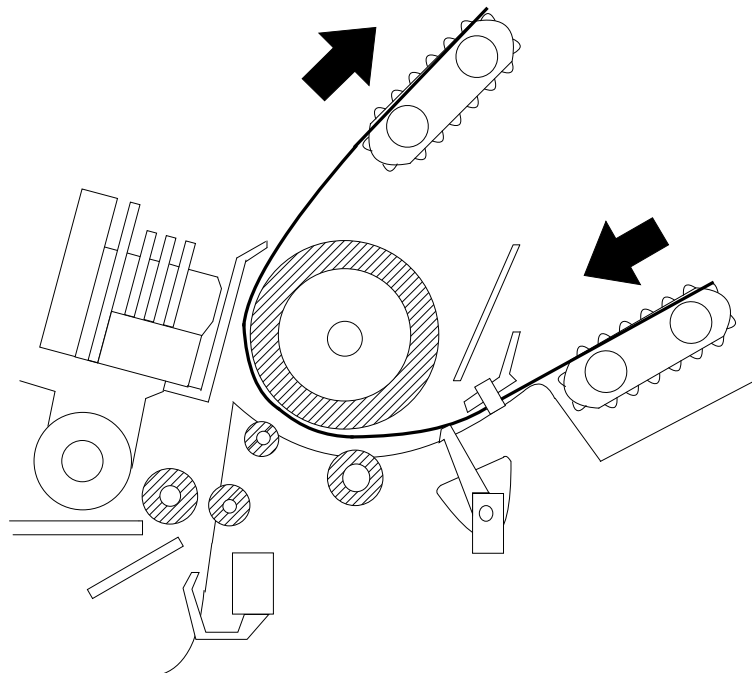

Figure 2-15. Push-Pull Tractor Feeding Using the Rear Entrance

As shown above in Figure 2-15, when you use the pull tractor with this printer, you must remove the paper eject cover, which includes the paper tension roller, from the printer mechanism.

3. Bottom Entrance

Figure 2-16 shows the paper path for tractor feeding using the bottom entrance. The bottom entrance is used only for pull tractor feed. When the bottom entrance is used, the front PE sensor detects when paper is out.

Figure. 2-16. Pull Tractor Feeding Using the Bottom Entrance

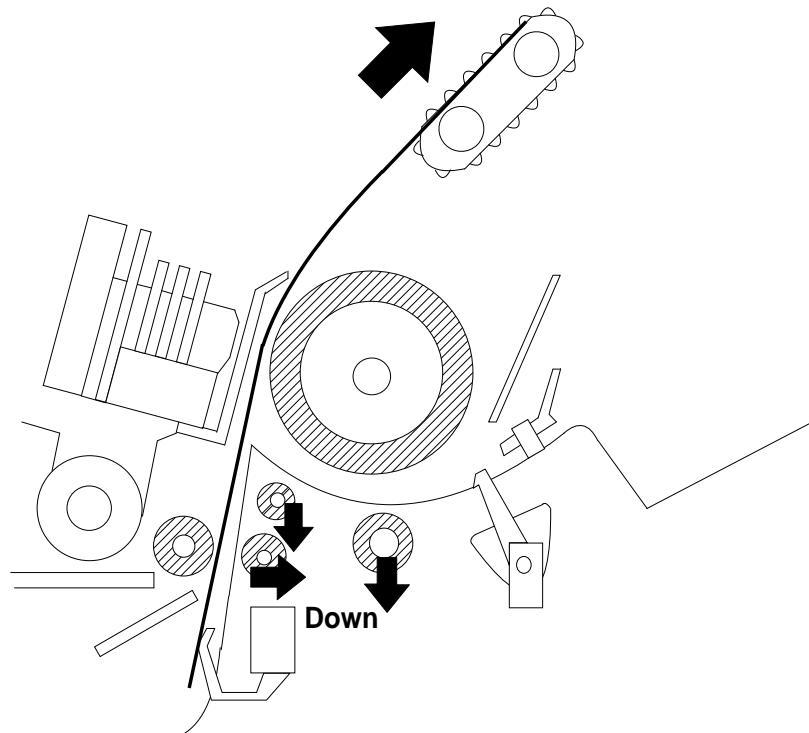

4. Front Entrance

Figures 2-17 through 2-20 show the paper paths for the front entrance. The front entrance can be used with any of the following paper feed methods: friction feed, push tractor feed, pull tractor feed, or push-pull tractor feed. When the front entrance is used, the front PE sensor detects when paper is out.

Figure 2-17 Friction Feeding Using the Front Entrance

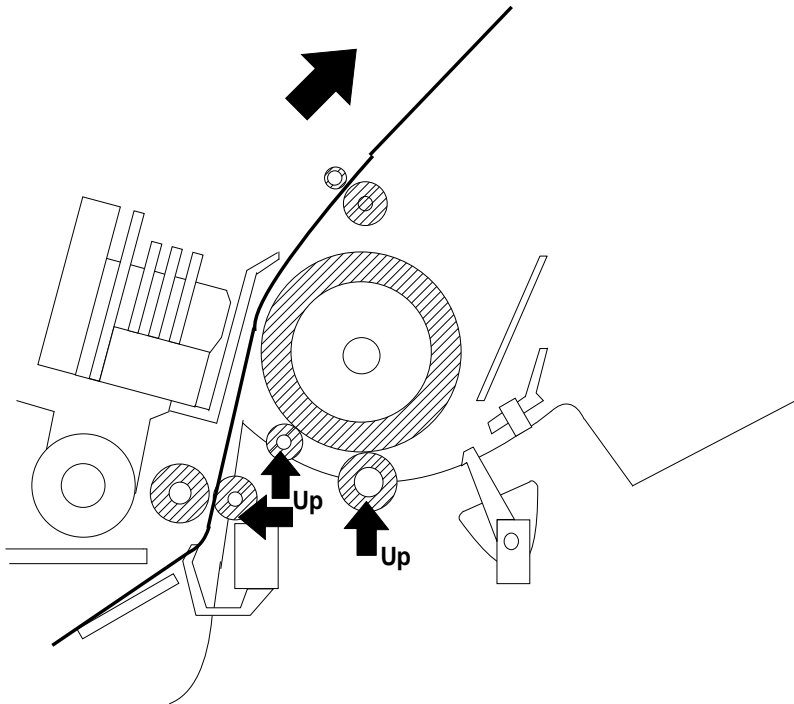
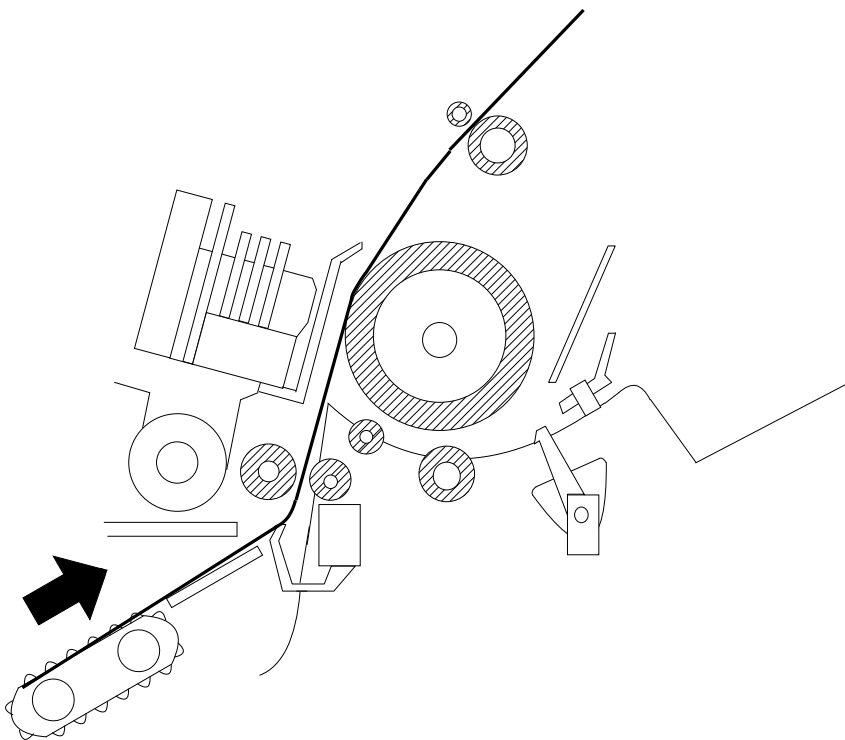

Figure 2-18 Push Tractor Feeding Using the Front Entrance



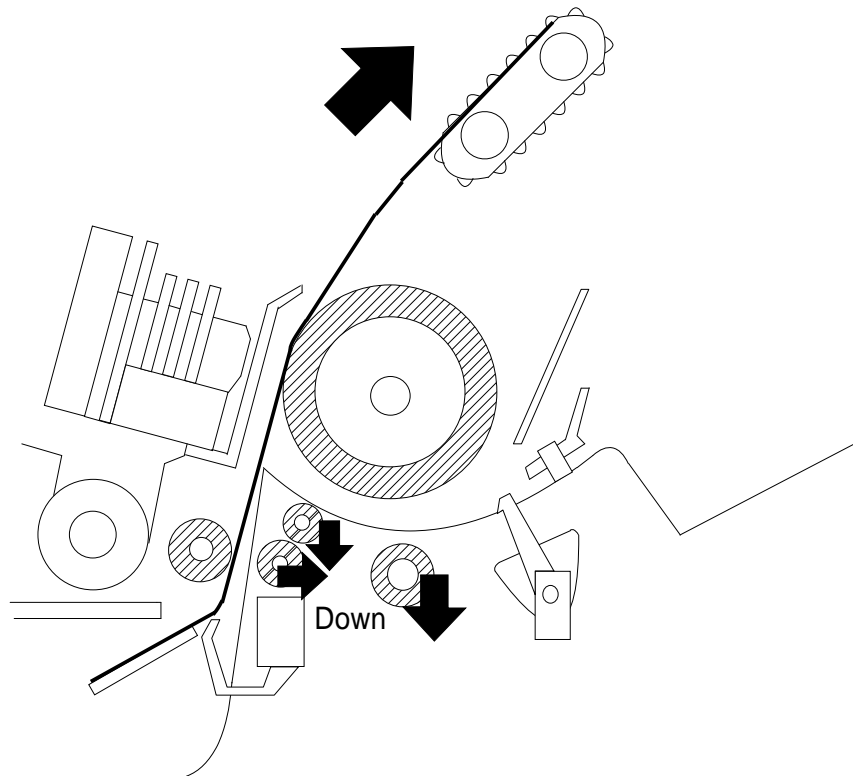

Figure 2-19 Pull Tractor Feeding Using the Front Entrance

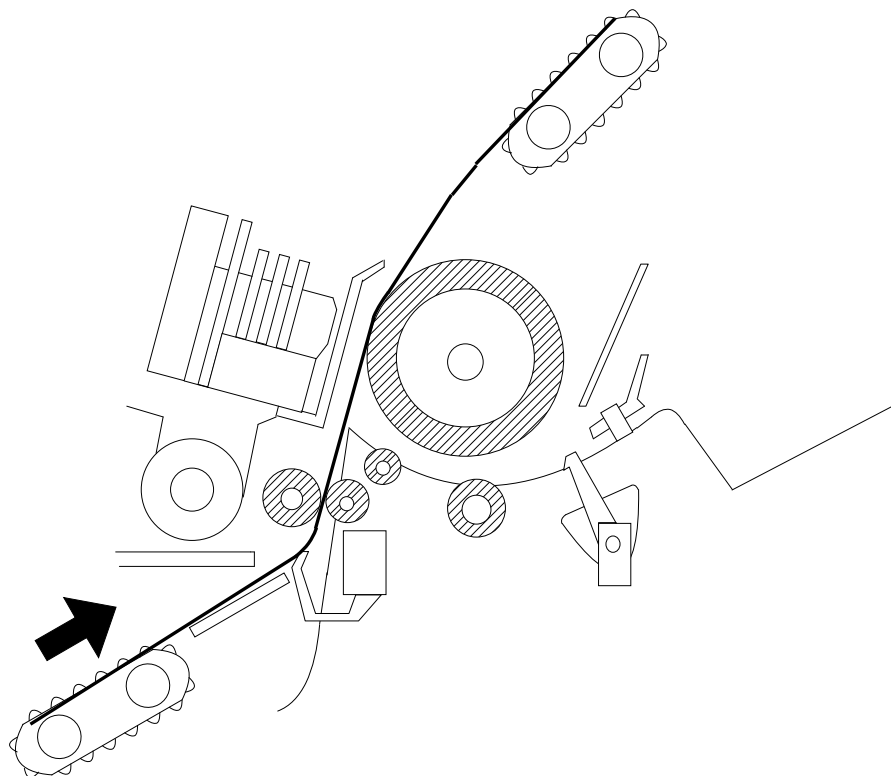

Figure 2-20 Push-Pull Tractor Feeding Using the Front Entrance

2.1.6 Ribbon Advance Mechanism

The ribbon is held between the ribbon advance roller (ribbon driven gear) and the ribbon pressure roller. When the carriage moves from left to right and vice versa on the CR guide shaft, the timing belt turns the belt-driven pulley. Then the torque is transmitted to the ribbon driving gear through the gear trains. The ribbon driving gear rotates counterclockwise, no matter what direction the carriage moves, because a planetary gear is used in the gear linkage.

Table 2-4. Ribbon Advance Gear Linkage

Direction of Carriage Movement	Gear Linkage
Left to right (indicated by the black arrow)	Belt driven pulley → Gear (1) → Gear (2) → Ribbon driving gear
Right to left (indicated by the white arrow)	Belt driven pulley → Gear (1) → Gear (3) → Gear (4) → Ribbon driving gear

The ribbon brake spring, attached to the exit of the cartridge case, prevents slack in the ribbon and keeps the ribbon tension at an appropriate level. The ribbon mask prevents the ribbon from brushing against the paper.

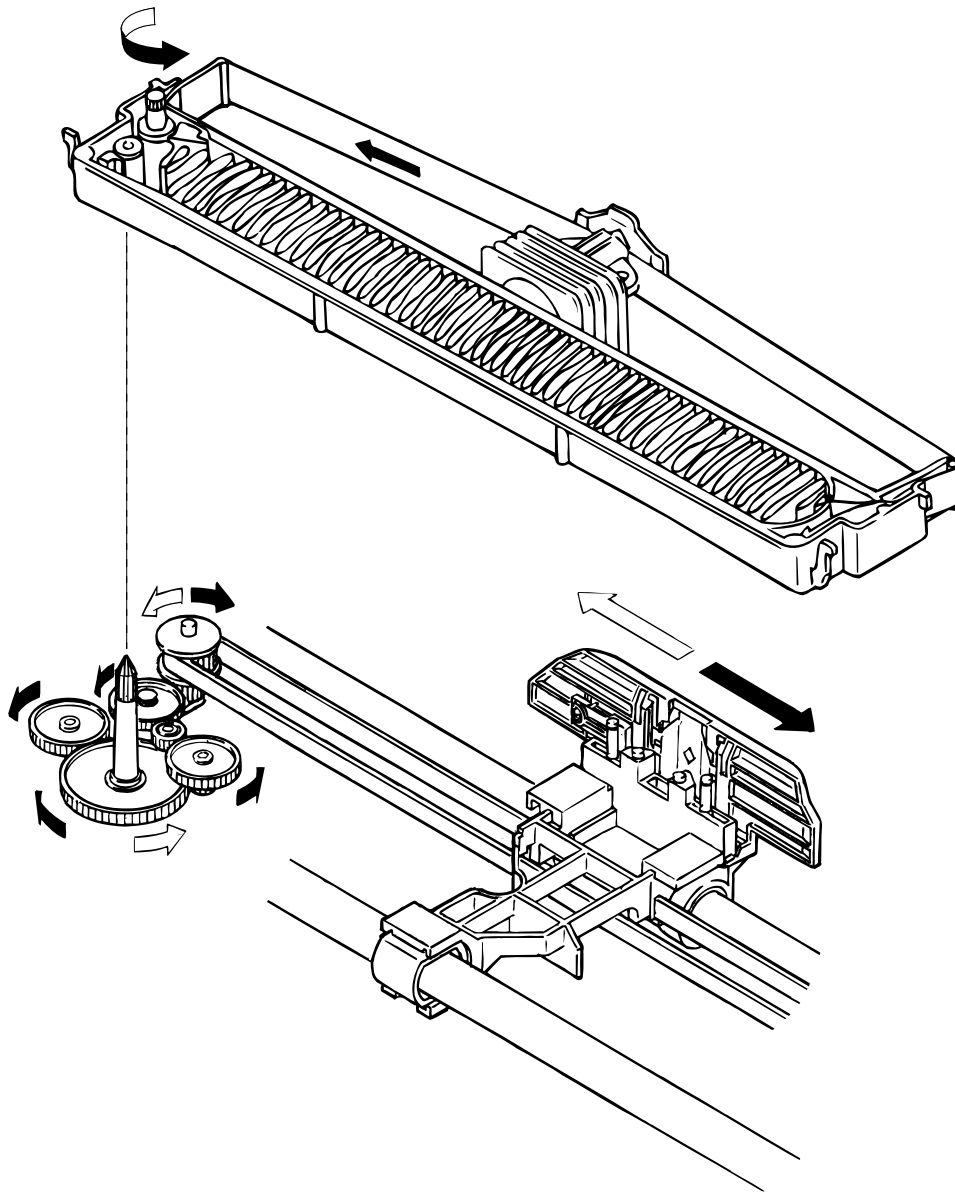

Figure 2-21 Ribbon Advance Mechanism

2.2 POWER SUPPLY OPERATION

The printer can be powered by either of two power supply boards: the C165 PSB (120 V) or C165 PSE (230 V) power supply. These boards are the same for both the LQ-2170 and FX-2170. Additionally, the PSB and PSE boards function the same, except for a difference in primary circuitry. The power supply board outputs the DC current necessary to drive the printer control circuits and drive mechanism. Table 2-5 shows the input voltages and fuse ratings for these boards.

Table 2-5. Power Supply Board

Board	Input Voltage	Fuse F1 Rating
C165 PSB	103.5 to 132 VAC	6.3 A / 125 V
C165 PSE	198 to 264 VAC	T3.15 AH / 250 V

2.2.1 Power Supply Overview

The power supply board has two power outputs for use by the various control circuits and drive mechanisms. Table 2-6 lists the applications for the two DC output supply voltages.

Table 2-6 Power Supply Output Voltages and Applications

Output Voltage (DC)	Applications		
+5 V	Main Board Logic Circuit	Sensors	Control Panel LEDs
+35 V	CR Motor	PF Motor	Printhead Drive

Figure 2-22 shows a block diagram of the power supply circuitry.

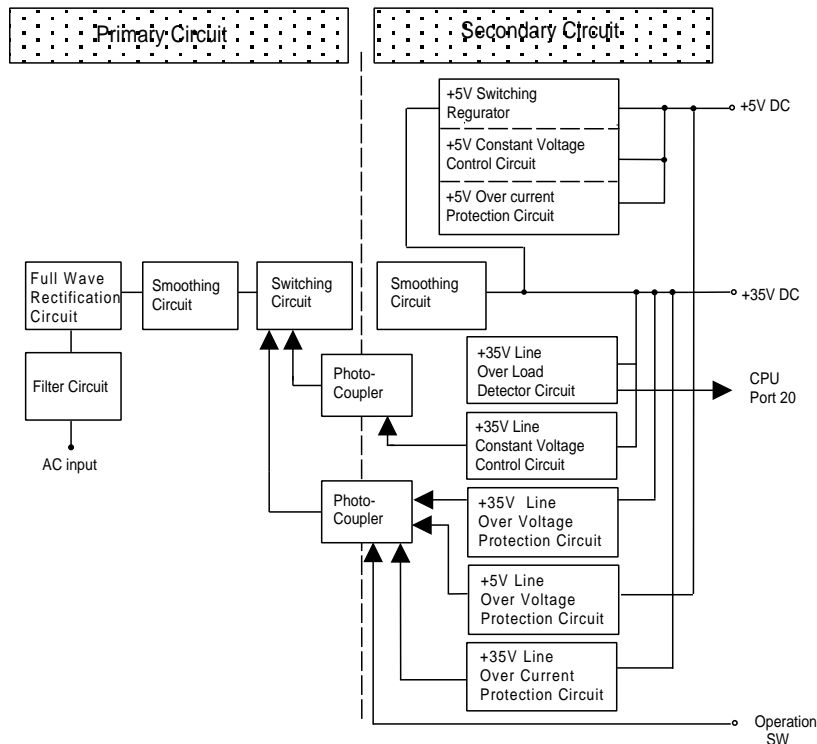

Figure 2- 22 Power Supply Circuit Block Diagram

As shown in the figure above, when AC power enters the printer from an external power source, the filter circuit removes the noise. The AC voltage then undergoes full-wave rectification and is smoothed to produce direct voltage. The voltage is fed to the gate port for the switching FET (Q1: K1531 or K1692) through resistors R18 and R31, and then the switching circuit operates. The secondary smoothing circuit produces a stepped down +35 VDC voltage. The +5 VDC voltage is generated by feeding the +35 VDC voltage through the +5 VDC power supply circuit, where the +35 VDC is stepped down to a stable +5 VDC from the 35 VDC line.

2.2.2 Power Supply Circuit Operation

The power supply circuit is composed of an RCC (ringing choke converter) system and the power switch circuit in the secondary circuitry. The power supply circuit has several protection and control circuits. This section describes these circuits.

1. Power Switch Circuit

The power switch circuit is in the secondary circuitry. It is shown in the illustration below.

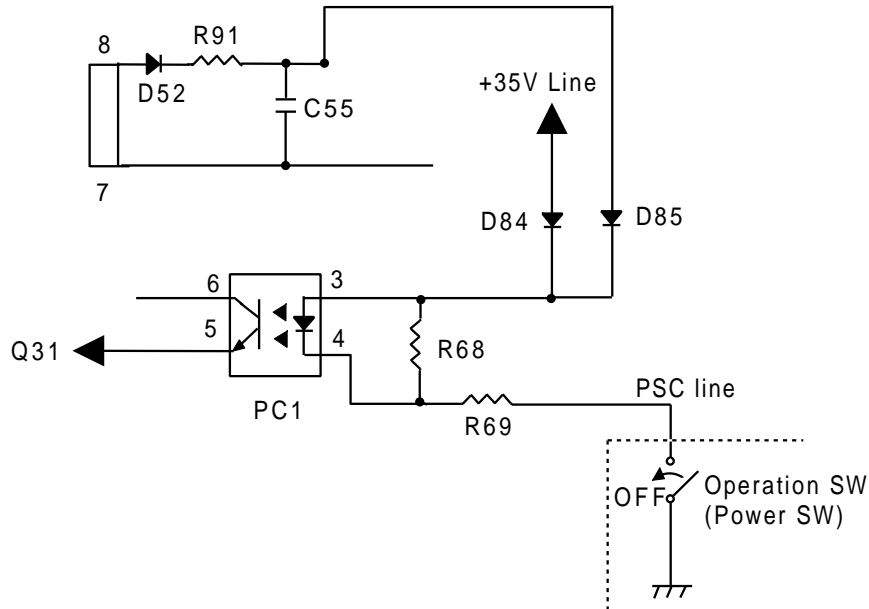

Figure 2-23 Power Switch Circuit

When printer power is off, the PSC line is connected to a ground line and the current is loaded from C55 to PC1. Consequently, Q32 and Q31 are turned on, and the switching FET is shut off.

(2) +35 V/+5 VDC Line Over Voltage Protection Circuit

This circuit is shown below.

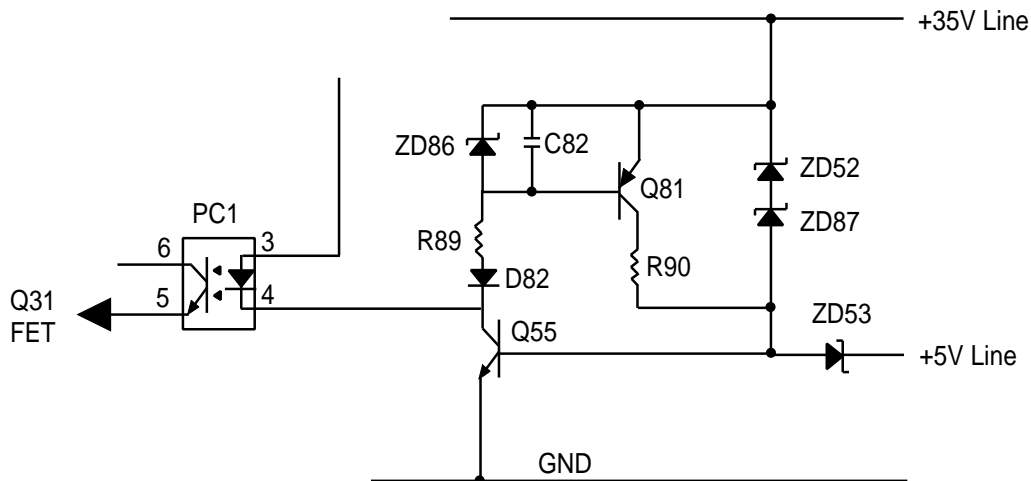

Figure 2-24 Over Voltage Protection Circuit

The +35 VDC over voltage protection circuit operates when voltage exceeds 42.42 V between ZD52 and ZD87 and shuts off the switching FET (Q1: K1692 or K1531). The +5 VDC over voltage protection circuit operates when voltage exceeds 7.5 V between ZD53, and shuts off the switching FET (Q1: K1692 or K1531). When either of these protection circuits operate, the protection cannot be removed without turning power off and on again.

3. +35 V Constant Voltage Control Circuit

The +35 V constant voltage control circuit is illustrated below.

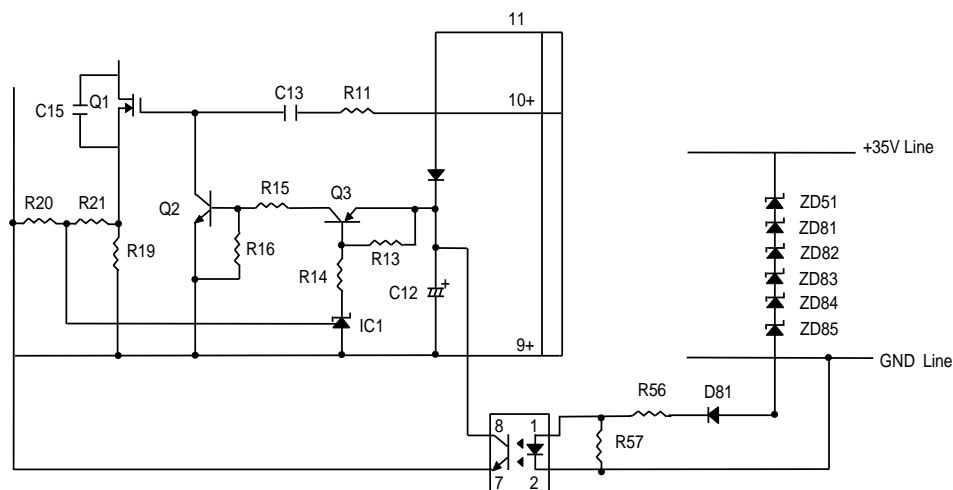

Figure 2-25 +35 V Line Constant Voltage Control Circuit

The constant voltage control circuit operates to keep the 35 V line at $35\text{ V} \pm 6\%$. When the voltage between ZD51 and ZD85 becomes $32.7\text{ V} \pm 2.75\%$, PC1 turns on, and then Q2 also turns on. Consequently, switching FET Q1 shuts off. When the voltage between ZD51 and ZD85 becomes less than $32.7 \pm 2.75\text{ V}$, PC1 turns off, and then Q2 also turns off. Consequently, switching FET Q1 operates again. Repeating the above operation keeps the +35 V line at $35\text{ V} \pm 6\%$.

4. +35V Line Overload Detection Circuit

The +35 V line voltage drop protection circuit is shown in the figure below.

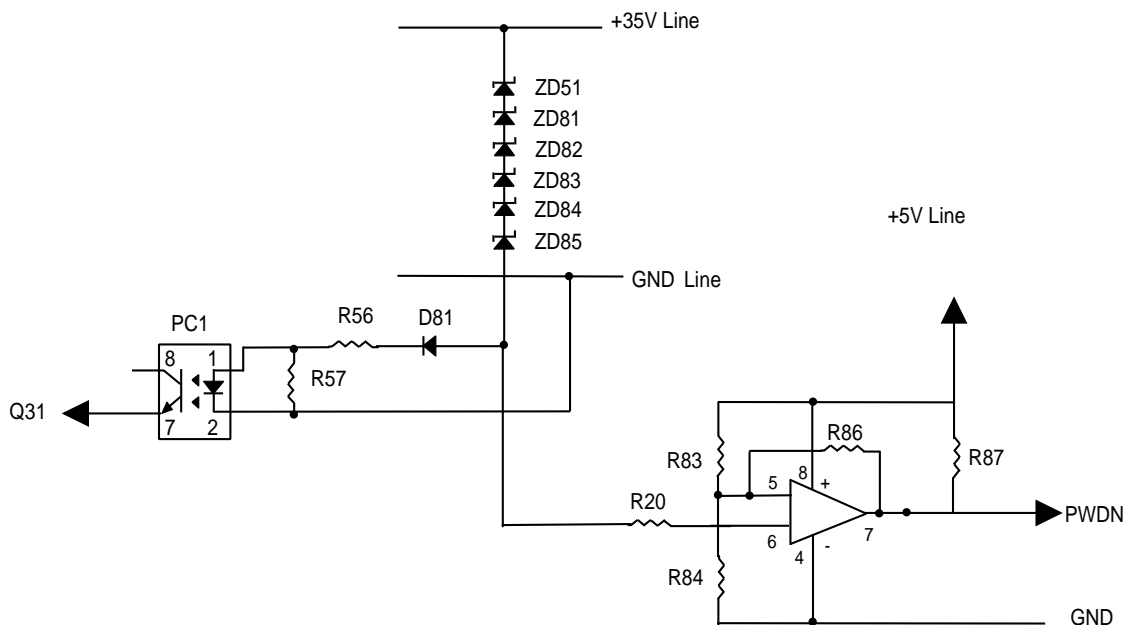

Figure 2-26 +35 V Line Overload Detection Circuit

When the +35 V line is overloaded, it means that constant voltage control is not being maintained. In this condition, the forward current of PC1 drops to 0 A. Consequently, voltage V_f between PC1 and D81 also drops. On this circuit, when the V_f voltage drops below 1.3 V (+35 V line: 33.1 V), IC528 detects the overload and outputs the PWDN signal (+5 V: HIGH active) to port 20 of the CPU. When the CPU receives this PWDN signal, printing stops. When the +35 V line becomes normal again, the voltage between PC1 and D81 also becomes normal. When the V_f voltage goes above 1.6 V (+35 V line: 33.4 V), the PWDN signal is removed.

5. +35 V Line Over Current Protection Circuit

The +35 V line over current control circuit is illustrated below.

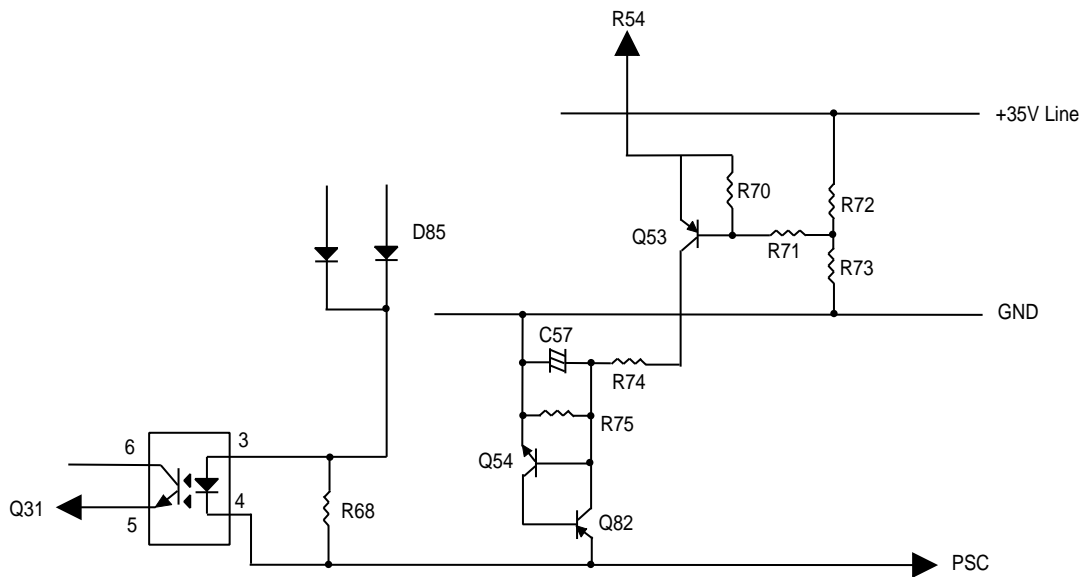

Figure 2-27 +35 V Line Over Current Protection Circuit

When the +35 V line becomes less than 27 V, Q82 and Q54 turn on, and PC1 turns on. Consequently, Q32 and Q31 turn off, and then switching FET Q1 shuts off. When the protection circuit operates, this protection can only be removed by turning the power off and on again.

6. +5 V Line Over Current Protect Circuit

+5 V line over current control circuit is shown below.

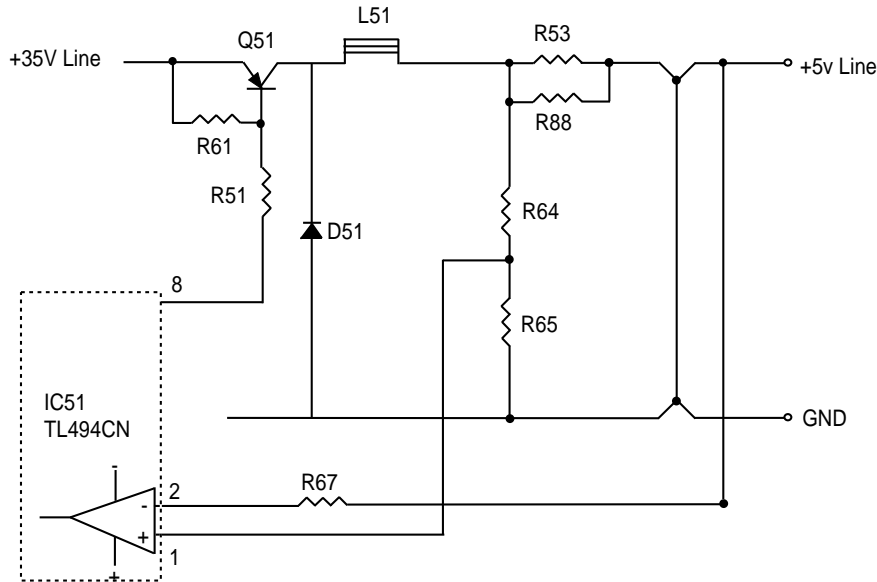

Figure 2-28 +5 V Line Over Current Protection Circuit

Port 2 of IC51 (TL494CN) monitors the +5 V line, and this protection circuit operates when the +5 V line goes below 4.75 V. When this circuit operates, port 8 signal output of the PWM pulse stops, and Q51 stops its switching operation. Consequently, the +5 V line stops generating.

7. +5 V Line Constant Voltage Control Circuit

The +5 V line constant voltage control circuit is shown below.

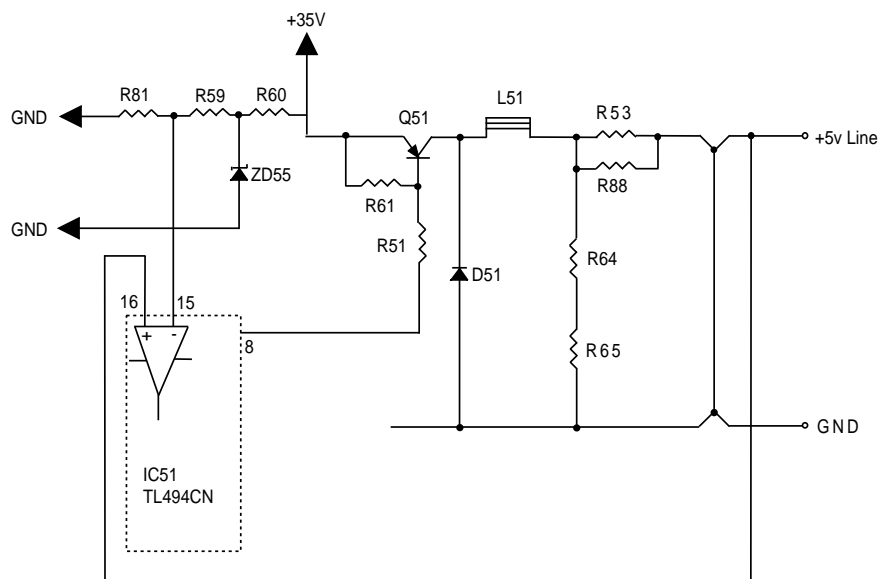

Figure 2-29 +5 V Line Constant Voltage Control Circuit

Port 16 of IC51 (TL494CN) monitors the + 5 V line, and the voltage is compared with the standard voltage, which is input into port 15. When the voltage of port 16 goes below 4.81 V or above 5.17 V, the pulse width of the PWM signal, which is output from port 8, changes and the +5 V line is kept between 4.81 V to 5.17 V.

2.3 CONTROL CIRCUIT

The control circuit consists of the C165 MAIN board assembly and C165 PNL board. This section describes the major components and explains how the boards work.

2.3.1 Overview of Control Circuit Operation

The printer's control circuit includes a TMP96C141AF CPU that runs at 17.20 MHz, an E05B13YA gate array, a 1M bit PS-RAM (8-bit bus, less than 80ns), a 2M bit PROM (8-bit bus, less than 120ns), 4M CG (Standard Version) or 8M CG (NLSP Version). It oversees control of all the components in the printer. The following chart shows you a block diagram of the control circuit.

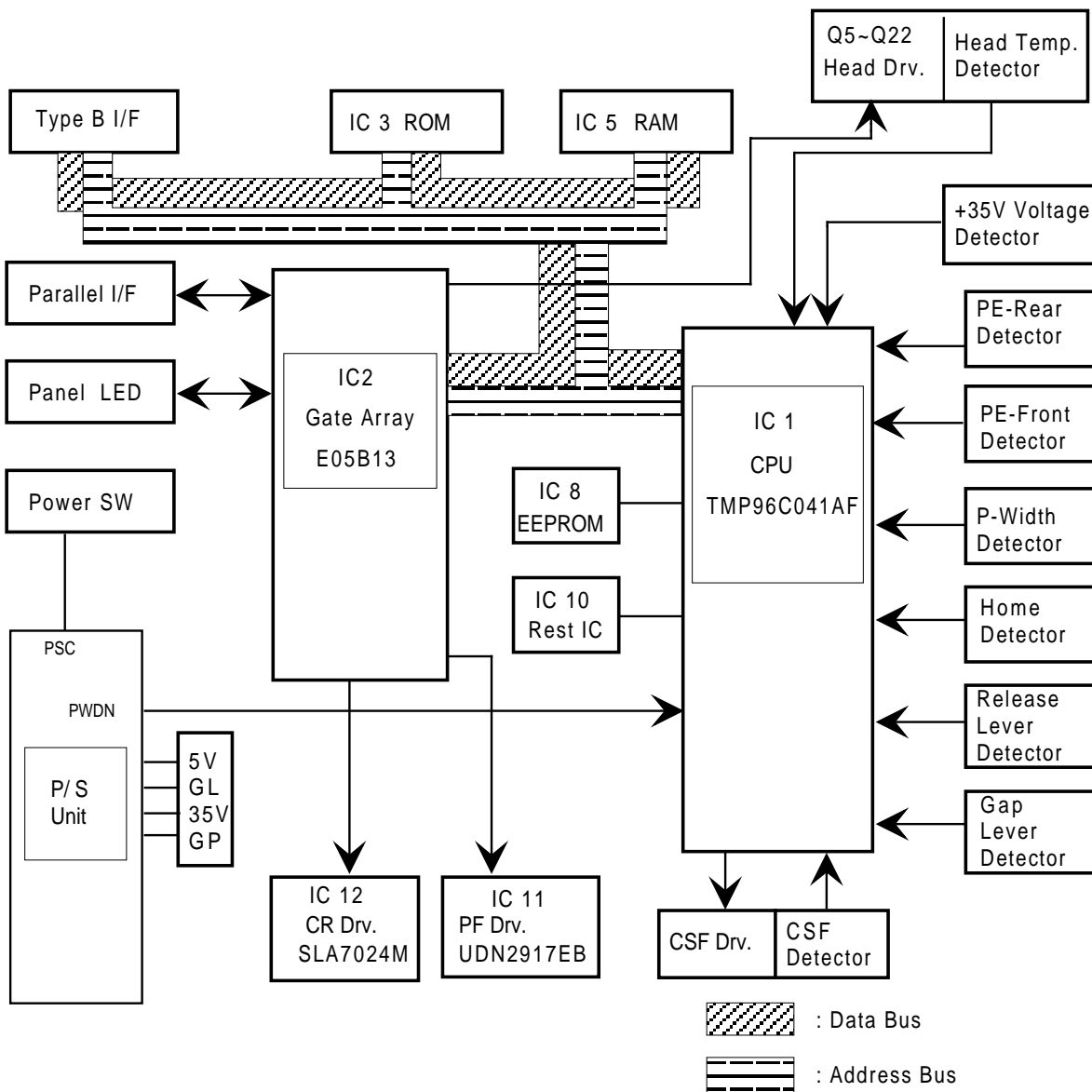

Figure 2-30 Control Circuit Block Diagram

The following figure shows the data flow from the host computer to the printhead. Data sent from the host computer is converted to image data and transmitted to the printhead through the gate array.

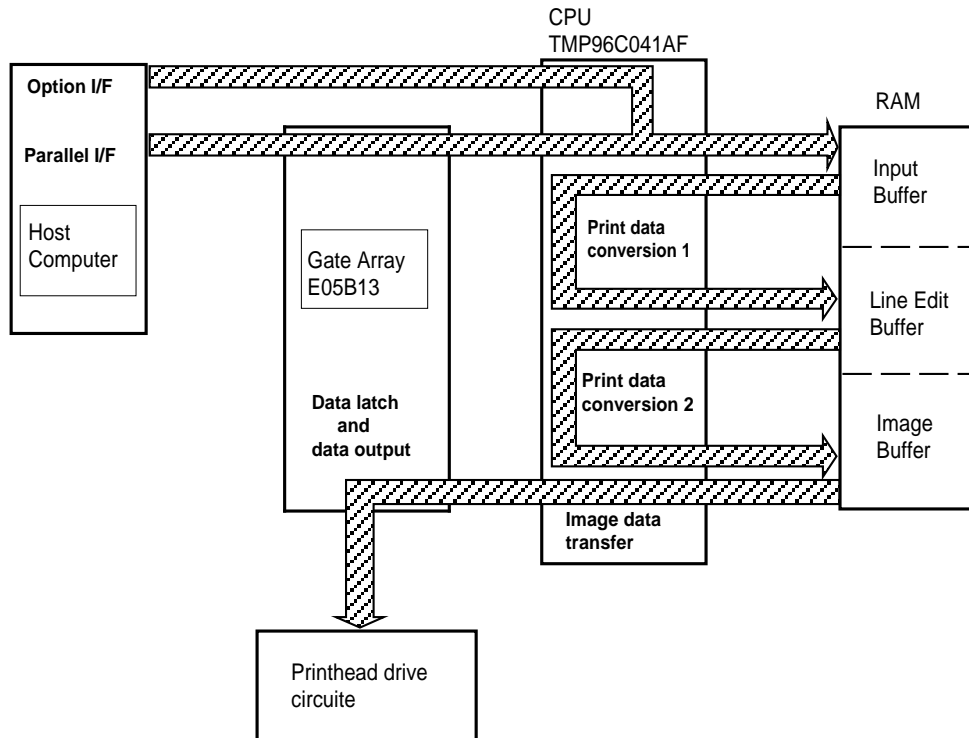

Figure 2-31 Data Flow

The following table lists the each function of the main components of the C165 MAIN board.

Table 2-7 Functions of the Main Board

IC	Location	Function
CPU	IC1	Receives data from the host computer and sends it to the input buffer in RAM (under interrupt processing control). Extends the input data held in the buffer to create image data. Loads this image data to the image buffer in RAM. Transfers the image data to the printhead drive circuit.
Gate Array	IC2	Controls the functions below: <ul style="list-style-type: none"> • Controls output data from the internal block • Memory management • Address latch of the address/data bus from the CPU • Clock control unit • Bit manipulation • Interface control • Expanded parallel port • Printhead control • Motor control
EEPROM	IC 8	An electrically writable and erasable ROM used to hold such information as the TOF position and bidirectional adjustment value.
ROM	IC 3	The ROM contains the program that runs the CPU and holds the character design (also called the character generator).
RAM	IC 5	The RAM contains the CPU working area and the buffers
CG	IC 6	The CG contain the bit map font of each character table
SLA7024M	IC 12	Drive circuit for the CR motor
UDN2917EB	IC 11	Drive circuit for the PF motor

2.3.2 System Reset Circuit

Control circuits IC1 and IC2 are initialized when a $\overline{\text{RESET}}$ signal (LOW level) is output from port 1 (VOUT) of IC10. IC10 monitors the +5 V line on port 3, and resets under the following conditions:

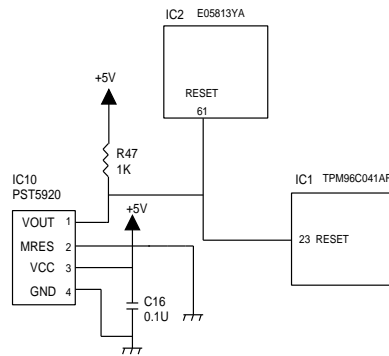

Figure 2-32 Reset Circuit

1. When the power supply is turned on, a $\overline{\text{RESET}}$ signal is output. $\overline{\text{RESET}}$ is canceled when the +5 V line goes up to 4.2 V, and then 100 ms passes.
2. When the +5 V line goes below +4.2 V, a $\overline{\text{RESET}}$ signal is output. $\overline{\text{RESET}}$ is canceled when the +5 V line goes back up to 4.2 V and then 100 ms passes.

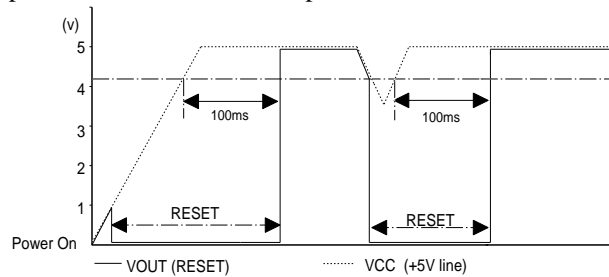

Figure 2-33 Reset Signal Output Timing

2.3.3 Printhead Driver Circuit

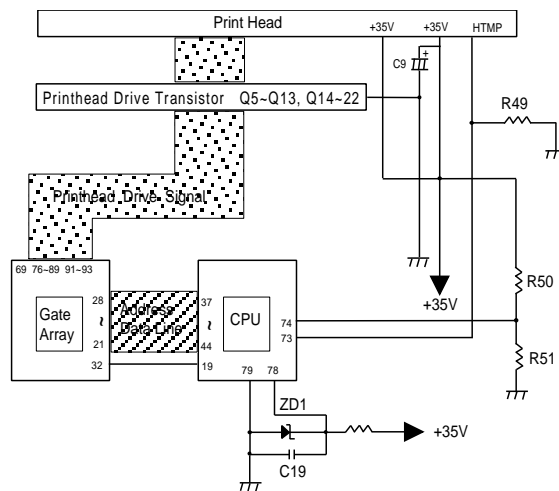

Figure 2-34 Printhead Drive Circuit

The standard voltage for the A/D converter is made in ZD1 and input to CPU port 78. Based on this standard voltage, the A/D converter in the CPU operates. Port 74 monitors the +35 V line between R50 and R51 to determine the printhead drive pulse width. Using the monitored voltage, the CPU converts the voltage to a digital value and decides the printhead drive pulse width, and then transports the data to the gate array via CPU port 19. Based on the monitored voltage, the CPU decides the printing interval. Port 73 monitors the printhead temperature to protect the printhead. If the temperature exceeds 110° C (228° F) , printing is stopped.

2.3.4 CR Motor Driver Circuit

The CR motor driver circuit is shown below.

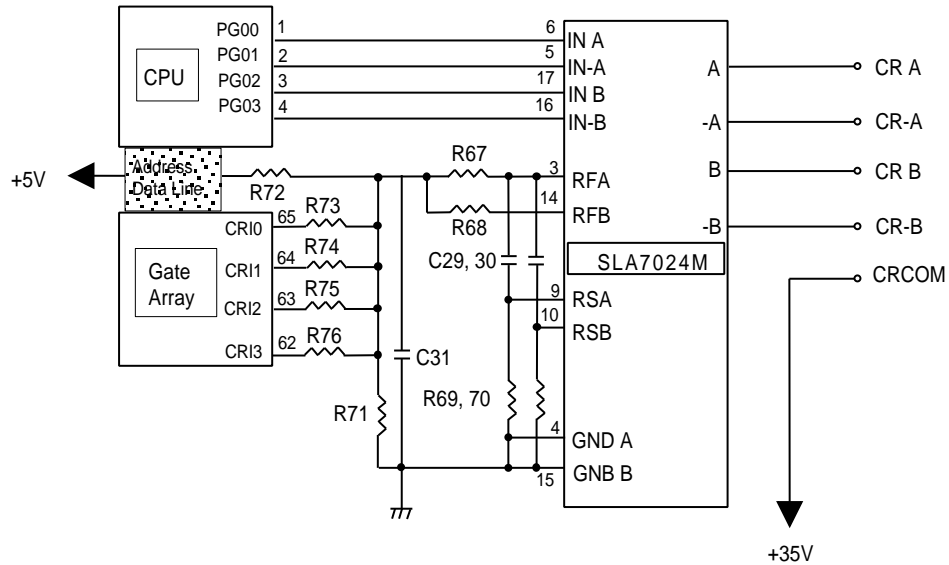

Figure 2-35 CR Driver Circuit

The carriage motor driver circuit controls the CR motor, using an open-loop, constant drive arrangement. 2-2 and 1-2 phases excite the motor. A 2-2 phase step is equivalent to a 1-2 phase step doubled. Ports 1 to 4 of the SLA7024M are used to change the excitation phase, depending on the selected print mode. Table 2-8 describes the motor driver modes.

Table 2-8 CR Motor Driver Modes

Speed Mode	Print Speed (CPS)	Drive Frequency (PPS)	Excitation Phase	Applications
8/3	440	5280	2-2	Super Draft
3	330	3960	2-2	Draft
8/3	293.3	3520	2-2	Super Draft and Copy
2	220	5280	1-2	Super Draft & Power down Draft & Copy
3/2	165	3960	1-2	Draft & Power down
1	110	2640	1-2	Super draft & Copy & Power down Draft & Copy & Power down LQ
3/4	82.5	1980	1-2	Bit Image & Power down
2/3	73.4	1760	1-2	LQ & Copy
1/2	52.5	1320	1-2	LQ & Power down LQ & Copy & Power down

The SLA7024M (IC12) CR motor driver circuit detects and regulates the amount of current flowing in the carriage motor coil. The current flowing through the coil varies, depending on the speed of the CR motor. The CPU sets the amount of current via the Address /Data line. Signals are sent to ports 3 (RFA) and 14 (RFB) of the SLA7024M. The SLA7024M sets the coil current, depending on the CR speed.

2.3.5 PF Motor Driver Circuit

The figure below shows the PF motor driver circuit.

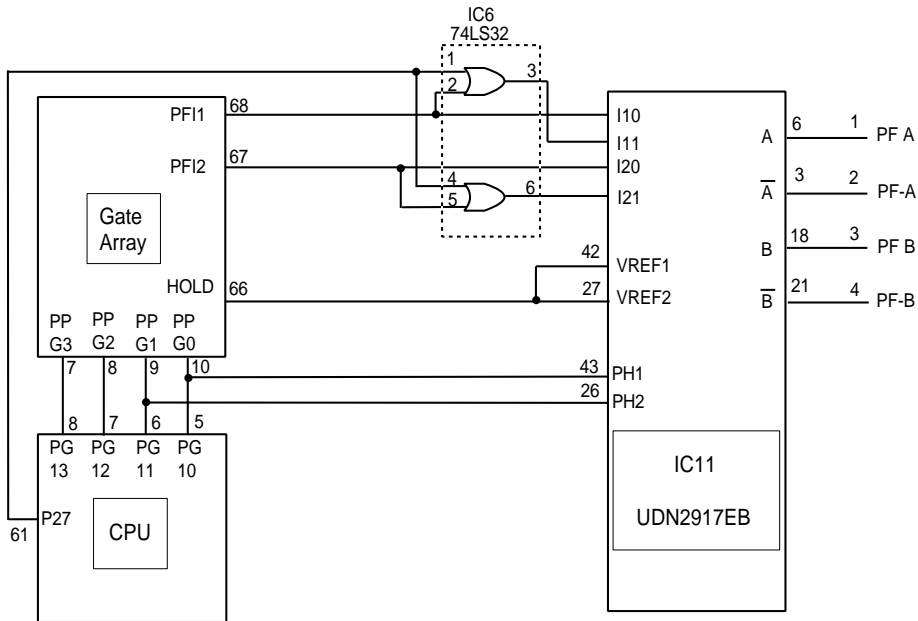

Figure 2-36 PF Motor Driver Circuit

The gate array receives phase data from the CPU via ports 5 (PG10), 6 (PG11), 7 (PG12), and 8 (PG13), converts the data to UDN2917 form, and then sends that phase data to ports 43 (PH1) and 26 (PH2). The PF driver current is controlled by the 74LS32 using port 68 (PF1) and 67 (PF2) signals output from the gate array and port 61 (P27) output from the CPU. These controlled drive currents are output to ports 2 (I10), 1 (I11), 23 (I20), and 24 (I21) of the UDN2917EB.

2.3.6 EEPROM Control Circuit

The EEPROM is non-volatile memory that stores information even if the printer power is off. The figure below shows the EEPROM control circuit.

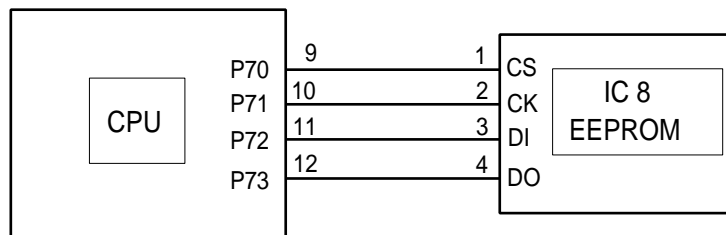

Figure 2-37 EEPROM Control Circuit

The EEPROM is controlled by CPU ports 9 (P70), 10 (P71), 11 (P72), and 12 (P73). Port 11 is the data output line used to save the information to the EEPROM, and port 12 is the data input line used to read the saved data from the EEPROM. Port 70 is the chip select line, and port 71 is the clock timing line. When the PWDN signal (power down) is detected on port 20 (INTO), the CPU writes the necessary data to the EEPROM before the +5 V line drops to 4.75 V.

2.3.7 Sensor Circuits

The CPU detects conditions of the following sensors: home position (HP) sensor, release sensors 1 and 2, platen gap (PG) sensor, rear and front paper end (PE) sensors, paper width (PW) sensor, and cover open sensor.

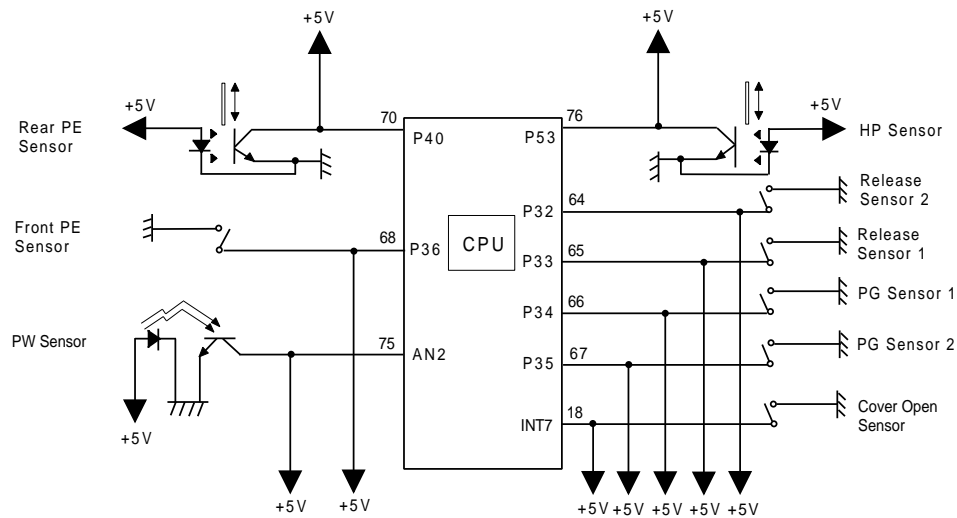

Figure 2-38 Sensor Circuits

Two types of sensors are used in this printer. Release sensors 1 and 2, PG sensors, the front PE sensor, and cover open sensor are momentary switches. Pages 2-3 and 2-4 describe the relationship between release and PG sensor operation and actual print operation.

The other type of sensor is used for the HP sensor, rear PE sensor, and PW sensor, which are photo diode switches. The HP sensor detects CR home position when the photo diode rays are cut off by the printhead. The rear PE sensor detects that paper has been loaded when the photo diode rays are cut off by the sensor plate, which is included in the rear PE sensor. The PW sensor, used for paper width measurement and paper loading positioning, detects the paper edge by comparing the measured voltage with standard voltage, which was measured during the power on sequence.

Additionally, as mentioned on the page 2-24, the +35 V line and head temperature are monitored to set the pulse length of the head drive signal.

CHAPTER 3 Disassembly and Assembly

Table of Contents

3.1 OVERVIEW	3-1
3.1.1 Precautions	3-1
3.1.2 Tools	3-1
3.1.3 Service Checks After Repair	3-2
3.1.4 Specifications for Screws	3-3
3.2 PRINTER DISASSEMBLY AND ASSEMBLY	3-4
3.2.1 Before Starting Disassembly Procedures	3-5
3.2.2 Removing the Panel Board Assembly	3-6
3.2.3 Removing the Printhead	3-7
3.2.4 Removing the HP Sensor	3-8
3.2.5 Removing the PW Sensor Assembly	3-8
3.2.6 Removing the Platen Assembly	3-10
3.2.7 Removing the Upper Housing Assembly	3-11
3.2.8 Removing the Case Open Sensor Assembly,	3-12
3.2.9 Removing the CR Motor Assembly	3-12
3.2.10 Removing the Printer Mechanism	3-13
3.2.10.1 Removing the PF Motor Assembly	3-14
3.2.10.2 Removing the PG Sensor Assembly	3-15
3.2.10.3 Removing the Right Frame Assembly	3-16
3.2.10.4 Disassembling the Right Frame Assembly	3-16
3.2.10.5 Removing the Left Frame Assembly	3-19
3.2.10.6 Removing the Ribbon Drive (RD) Assembly	3-20
3.2.10.7 Removing the CR Assembly	3-21
3.2.10.8 Removing the Rear PE Sensor Assembly	3-23
3.2.10.9 Removing the Front PE Sensor Assembly	3-23
3.2.11 Removing the C165 MAIN Board Assembly	3-24
3.2.12 Removing the C165 PSB/E Board Assembly	3-25
3.3 DISASSEMBLY AND ASSEMBLY OF CSF BIN 1	3-26
3.3.1 Disassembling the Right Side Block	3-26
3.3.2 Disassembling the Paper Support Block Assembly	3-28
3.3.3 Removing the Paper Eject Cover Assembly	3-30
3.4 DISASSEMBLY AND ASSEMBLY OF CSF BIN 2	3-31
3.4.1 Disassembly Right Side Block	3-31
3.4.2 Disassembly Paper Support Block Assembly	3-32

List of Figures

Figure 3-1. Screw Types and Abbreviations	3-3
Figure 3-2. Flowchart for Disassembling the Printer	3-4
Figure 3-3. Before Starting Disassembly Procedures	3-5
Figure 3-4. Removing the Panel Board Assembly	3-6
Figure 3-5. Lock Cover for CN1 and the FFC	3-6
Figure 3-6. Removing the Printhead	3-7
Figure 3-7. Connecting the Printhead FFCs	3-7
Figure 3-8. Removing the HP Sensor	3-8
Figure 3-9. Removing the PW Sensor Assembly	3-8
Figure 3-10. Mounting Position for the PW Sensor Assembly	3-9
Figure 3-11. Releasing the Locks for the Bushings	3-10
Figure 3-12. Removing the Platen Assembly	3-10
Figure 3-13. Releasing the Upper Housing Assembly Hooks	3-11
Figure 3-14. Removing the Upper Housing Assembly	3-11
Figure 3-15. Removing the Case Open Sensor Assembly	3-12
Figure 3-16. Removing the CR Motor Assembly	3-12
Figure 3-17. Removing the Printer Mechanism	3-13
Figure 3-18. Removing the PF Motor	3-14
Figure 3-19. Removing the PG Sensor Assembly	3-15
Figure 3-20. Removing the Right Frame Assembly	3-16
Figure 3-21. Removing the Right Sub Frame	3-16
Figure 3-22. Engaging Gears 1	3-17
Figure 3-23. Engaging Gears 2	3-18
Figure 3-24. Engaging the Tractor Clutch Cam	3-18
Figure 3-25. Removing the Left Frame Assembly	3-19
Figure 3-26. Cable Connection for the Release Lever Sensors	3-19
Figure 3-27. Removing the RD Assembly	3-20
Figure 3-28. Engaging Gears for the RD Assembly	3-20
Figure 3-29. Disconnecting the FFC	3-21
Figure 3-30. Removing the CR Assembly	3-21
Figure 3-31. Inserting the Timing Belt	3-22
Figure 3-32. Inserting the Oil Pad into the CR Assembly	3-22
Figure 3-33. Assembling the Rear CR Guide Shaft	3-22
Figure 3-34. Removing the Rear PE Sensor Assembly	3-23
Figure 3-35. Removing the Front PE Sensor Assembly	3-23
Figure 3-36. Removing the C165 MAIN Board Assembly	3-24
Figure 3-37. Removing the C165 PSB/E Board Assembly	3-25
Figure 3-38. Direction for Mounting the Fan Motor	3-25
Figure 3-39. Releasing the Clips for the Right CSF Cover	3-26
Figure 3-40. Cable Alignment	3-27
Figure 3-41. Engaging 13 Gears	3-27
Figure 3-42. Removing the E-ring	3-28
Figure 3-43. Removing 1 Gear (29 mm)	3-28
Figure 3-44. Removing the CPB Tight Screw	3-28
Figure 3-45. Removing the Paper Support Block Assembly	3-29
Figure 3-46. Removing the Paper Feed Roller Cover	3-29
Figure 3-47. Removing the Paper Eject Cover Assembly	3-30
Figure 3-48. Assembling the Paper Eject Cover Assembly	3-30

Figure 3-49. Removing the Right CSF Cover	3-31
Figure 3-50. Engaging 5 Gears	3-31
Figure 3-51. Removing the E-ring and 2 CBS Screws	3-32
Figure 3-52. Removing the Paper Feed Roller Cover	3-32

List of Tables

Table 3-1. Recommended Tools	3-1
Table 3-2. Equipment Required for Maintenance	3-1
Table 3-3. Inspection Check List for Repaired Printer	3-2
Table 3-4. Screw Types and Abbreviations	3-3

3.1 OVERVIEW

This section describes various points to note when disassembling and assembling the printer.

3.1.1 Precautions

Follow the precautions below for disassembly or assembly.

WARNING

Before disassembling, assembling, or adjusting the printer, disconnect the power supply cable from the AC power socket. Failure to do so can cause physical injury. The power switch is wired in the secondary circuitry. Therefore, the printer's primary circuitry remains live even after the power switch is turned off.

Never touch primary parts of the power supply unit (including the heat sink) while the power supply cable is connected to the AC power socket.

CAUTION

To maintain efficient printer operation:

- *Use only recommended tools for maintenance work.*
- *Use only recommended lubricants and adhesives (see Chapter 6).*
- *Adjust the printer only in the manner described in this manual.*

3.1.2 Tools

Tables 3-1 and 3-2 list the tools recommended for disassembling, assembling, or adjusting the printer. Use only tools that meet these specifications.

Table 3-1. Recommended Tools

Tool	Part No.
Round-nose pliers	B740400100
Nippers	B740500100
Tweezers	B741000100
Soldering iron	B740200100
E-ring holder #2.5	B740800400
Phillips screwdriver No.2	B743800200
Standard screwdriver	B743000100
Thickness gauge	B776702201

Note: All tools are commercially available.

Table 3-2. Equipment Required for Maintenance

Description	Specification
Multimeter	—
Oscilloscope	50 MHz

Note: An oscilloscope is required only for servicers who repair to the component level.

3.1.3 Service Checks After Repair

Before returning the printer after service, use the check list in Table 3-3, which provides a record to make servicing and shipping more efficient.

Table 3-3. Inspection Check List for the Repaired Printer

Category	Component	Item to Check	Is Check Required?
Printer units	Printhead	Are any wires broken?	<input type="checkbox"/> Checked <input type="checkbox"/> Not necessary
		Are any wires worn out?	<input type="checkbox"/> Checked <input type="checkbox"/> Not necessary
^	Carriage mechanism	Does the carriage move smoothly? <input type="checkbox"/> Movement noisy <input type="checkbox"/> Mechanism dirty <input type="checkbox"/> Mechanism oily	<input type="checkbox"/> Checked <input type="checkbox"/> Not necessary
^		Is the CR motor at the correct temperature (not overheating)	<input type="checkbox"/> Checked <input type="checkbox"/> Not necessary
^	Paper advance mechanism	Is paper advancing smoothly? <input type="checkbox"/> Movement noisy <input type="checkbox"/> Mechanism dirty <input type="checkbox"/> Mechanism oily	<input type="checkbox"/> Checked <input type="checkbox"/> Not necessary
^		Is the paper feed motor running at the correct temperature (not overheating)	<input type="checkbox"/> Checked <input type="checkbox"/> Not necessary
^	Paper path	Is the <i>type</i> of paper in the printer feeding smoothly?	<input type="checkbox"/> Checked <input type="checkbox"/> Not necessary
		Is the tractor feeding the paper correctly?	<input type="checkbox"/> Checked <input type="checkbox"/> Not necessary
		Is the paper path clear of all obstructions?	<input type="checkbox"/> Checked <input type="checkbox"/> Not necessary
		Is the platen free of damage?	<input type="checkbox"/> Checked <input type="checkbox"/> Not necessary
	Ribbon mask	Is the ribbon mask free of distortion?	<input type="checkbox"/> Checked <input type="checkbox"/> Not necessary
	Self-test	Was the self-test successful?	<input type="checkbox"/> Checked <input type="checkbox"/> Not necessary
	On-line test	Was the on-line test successful?	<input type="checkbox"/> Checked <input type="checkbox"/> Not necessary
Adjustment	Printhead printing	Is the platen gap adjusted correctly?	<input type="checkbox"/> Checked <input type="checkbox"/> Not necessary
		Is the bidirectional print position adjusted correctly?	<input type="checkbox"/> Checked <input type="checkbox"/> Not necessary
	Default settings	Have user-changeable settings been reset to the default values?	<input type="checkbox"/> Checked <input type="checkbox"/> Not necessary
System upgrade	ROM version	ROM version _____.	<input type="checkbox"/> Checked <input type="checkbox"/> Not necessary
	Shipment	Has the ribbon been removed?	<input type="checkbox"/> Checked <input type="checkbox"/> Not necessary
		Have all relevant parts been included in the shipment?	<input type="checkbox"/> Checked <input type="checkbox"/> Not necessary

3.1.4 Specifications for Screws

Table 3-4 lists the abbreviations used in the following sections for small parts, such as screws and washers.

Table 3-4. Screw Types and Abbreviations

Abbreviation	Part Name
CPS	Cross-recessed pan head S-tight screw
CBB	Cross-recessed bind head B-tight screw
CBS	Cross-recessed bind head S-tight screw
CBN	Cross-recessed bind head N-tight screw
CBC	Cross-recessed bind head C-Lamitite screw
CBA	Cross-recessed bind head A-lamitite screw
CB(O)	Cross-recessed bind head with outside-toothed lock washer

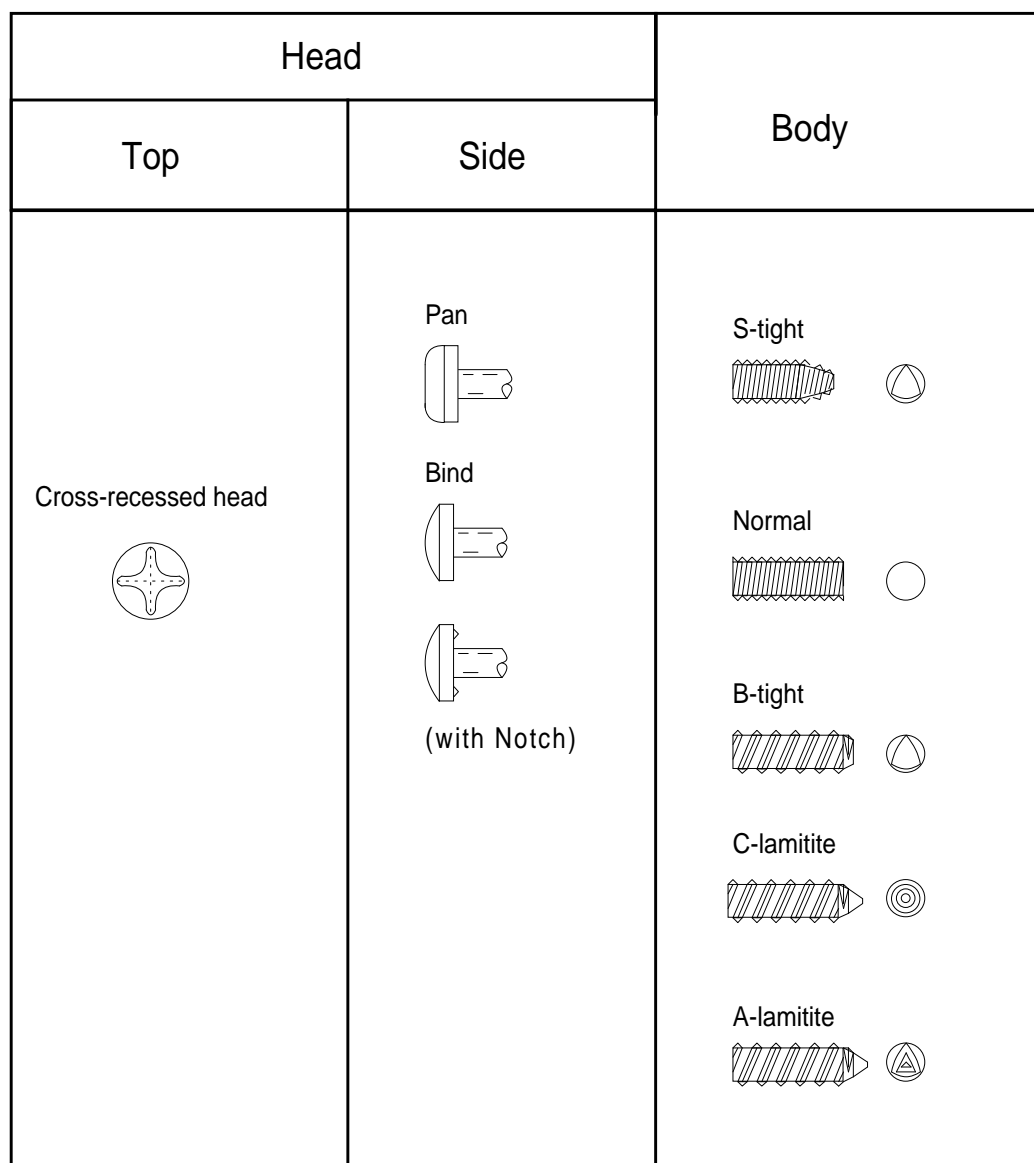

Figure 3-1 Screw Types and Abbreviations

3.2. PRINTER DISASSEMBLY AND ASSEMBLY

This section describes procedures for disassembling and assembling the main components of the printer. When the procedure for installing a component is simply the reverse of removing the component, this chapter does not describe the assembly procedure. If necessary, special notes on assembling or adjusting a component are given at the end of the description of each procedure. Be sure to follow the instructions in these notes.

CAUTION

- Before disassembling any part of the printer, note the warnings in Section 3.1.
- Before beginning to disassemble the printer, remove the paper and the ink ribbon. Also disconnect the interface cable.
- Whenever the printer is repaired, wipe the surface of the paper width (PW) sensor assembly with a soft cloth, and keep it clean to avoid abnormal operation. If the surface is dirty from any adhering material, sensor sensitivity goes down and operation is not correct.

Note: Exploded diagrams in the appendix show you how the components fit together. Refer to them as necessary. The flowchart below shows the order you need to use to disassemble the printer. For details of the required adjustments, refer to Chapter 4.

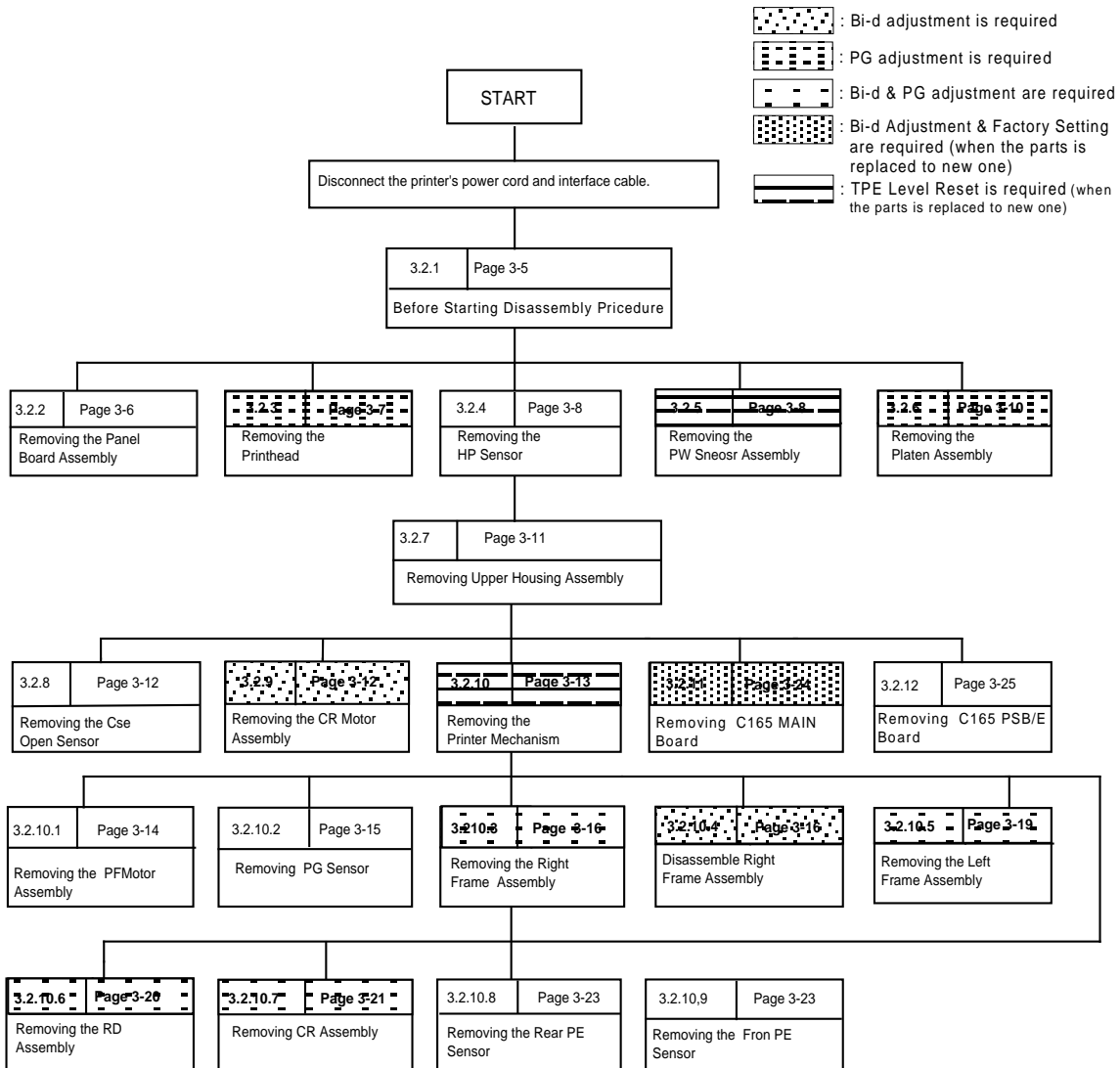

Figure 3-2 Flowchart for Disassembling the Printer

3.2.1. Before Starting Disassembly Procedures

1. Remove the following parts:

Front edge guide assembly

Front cover

Bottom cover

Rear edge guide assembly

Printer cover

Paper eject assembly

Front/rear tractor assembly

Ribbon cartridge

Refer to the following figure.

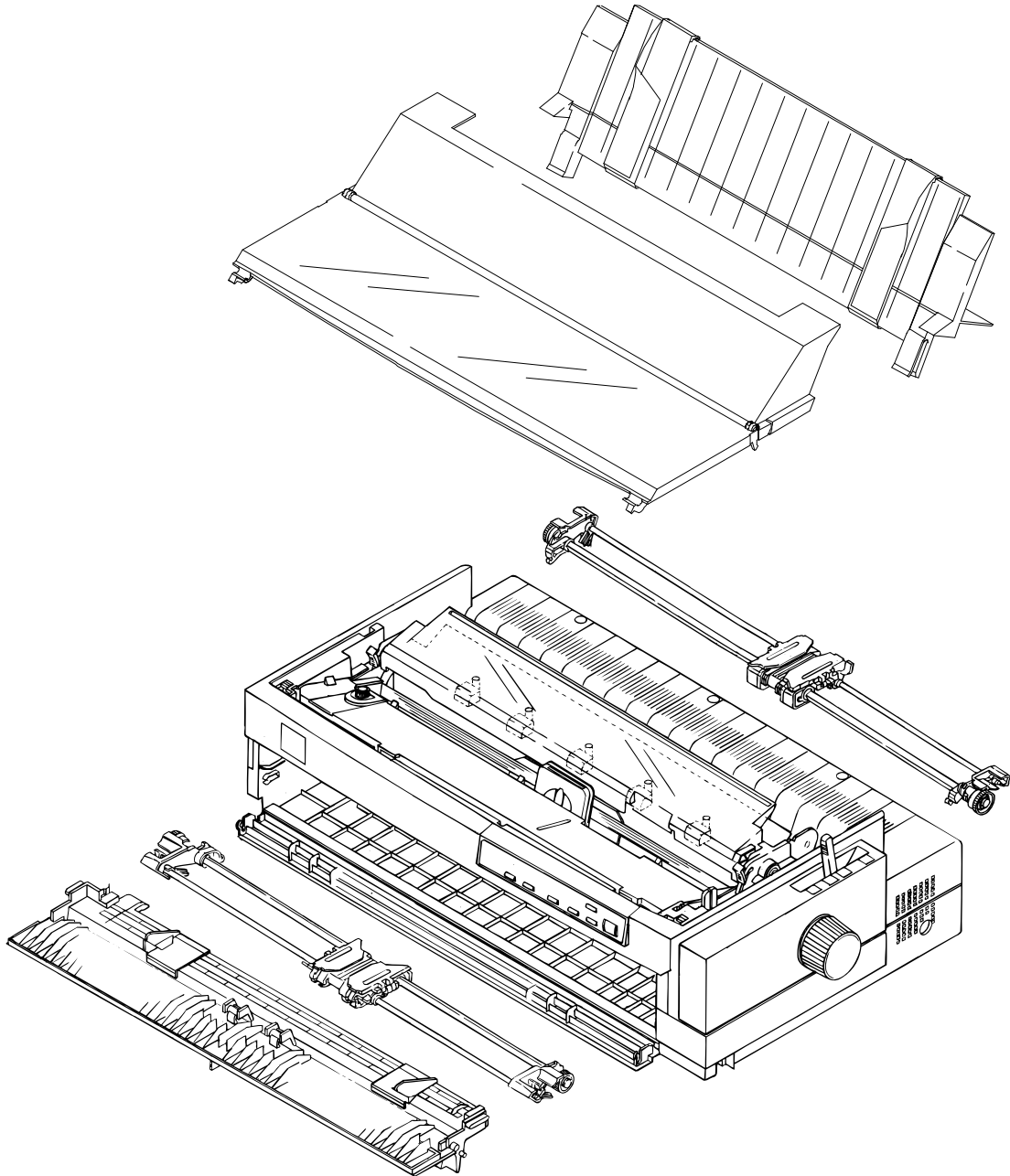

Figure 3-3 Before Starting Disassembly Procedures

Note

Remove the paper eject cover and the front/rear tractor assembly by pushing to release the hooks at both sides. When remounting them, be sure to snap the hooks on the projecting parts.

3.2.2. Removing the Panel Board Assembly

1. Remove the printer cover and ribbon cartridge (see Section 3.2.1).
2. Release the left clips for the panel board assembly by pushing them from the cutout located on the inside front of the upper housing assembly.
3. Release the flexible flat cable (FFC) by pulling the lock cover for CN1, and then disconnect the FFC for CN1 and connector CN2 from the C165 PNL board assembly.

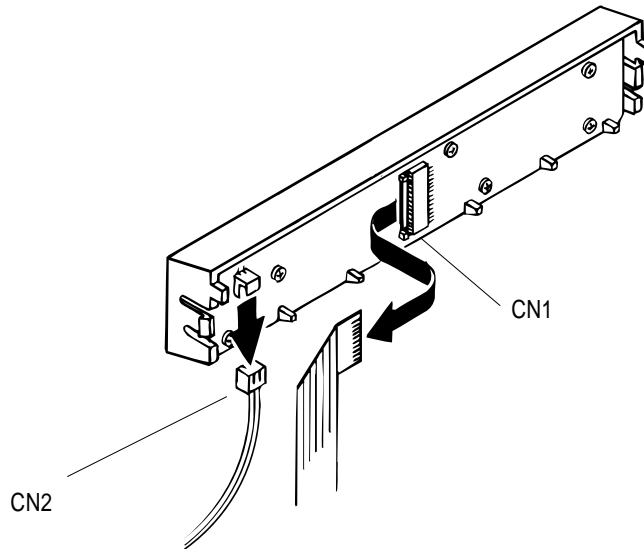

Figure 3-4 Removing the Panel Board Assembly

4. Remove the panel board assembly from the upper housing assembly.

Assembly Notes

Before disconnecting the FFC from CN1, slide the lock cover for CN 1 as shown in Figure 3-5, and release the FFC from CN1. After reconnecting the FFC for CN1, lock the lock cover .

The FFC must be connected properly, as shown in Figure 3-5. Exposed terminals must be connected face upward against the C165 PNL board.

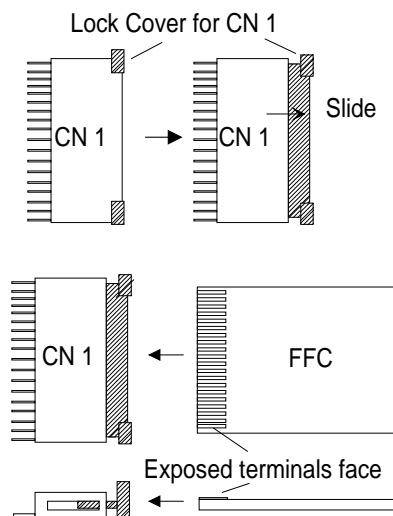

Figure 3-5 Lock Cover for CN1 and the FFC

3.2.3. Removing the Printhead

1. Remove the printer cover and ribbon cartridge (see Section 3.2.1).
2. Remove 2 CBS screws (3×10 , F/Zn) securing the printhead to the CR assembly.
3. Remove the printhead from the CR assembly.
4. Disconnect 2 wide FFCs from the printhead and then disconnect the narrow FFC from the connector on the CR cover.

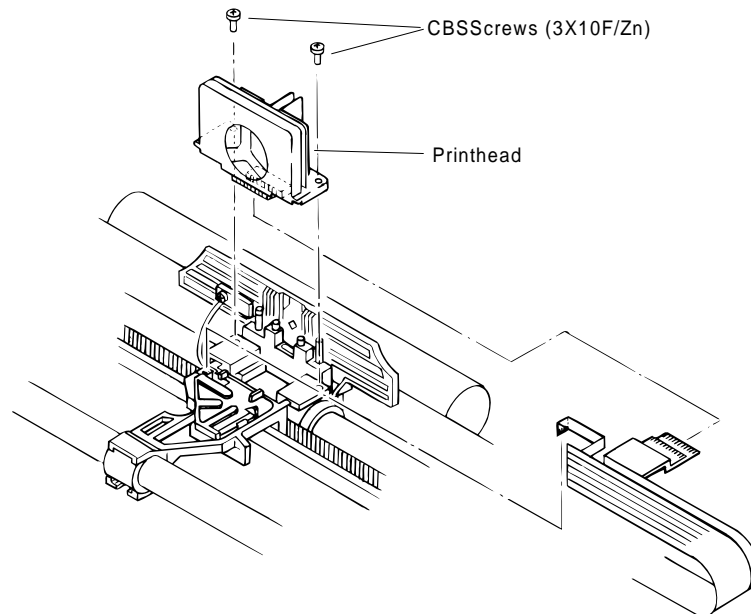

Figure 3-6 Removing the Printhead

Assembly Notes

The FFC must be connected properly, as shown in the following figure.

The tightening torque for the 2 CBS screws (3×10 , F/Zn) = $0.59 \sim 0.78 \text{ Nm}$ ($6 \sim 8 \text{ Kg f. cm}$)

Adjust the platen gap. Refer to Chapter 4.

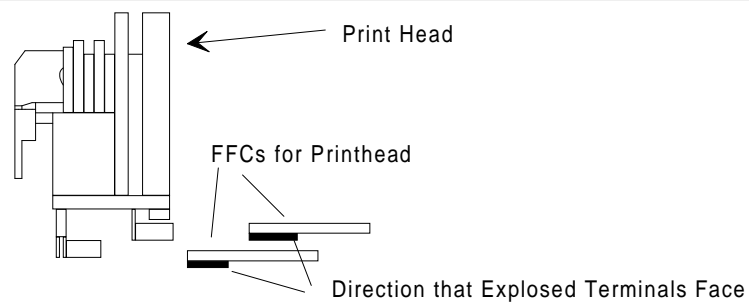

Figure 3-7 Method for Connecting the Printhead FFC

3.2.4 Removing the HP Sensor

1. Remove the printer cover, ribbon cartridge, front edge guide, and front cover (see Section 3.2.1).
2. Disconnect the connector cable for the HP sensor.
3. Remove the HP sensor by pushing up and releasing the 2 clips at the bottom of the HP sensor from the front paper entrance.

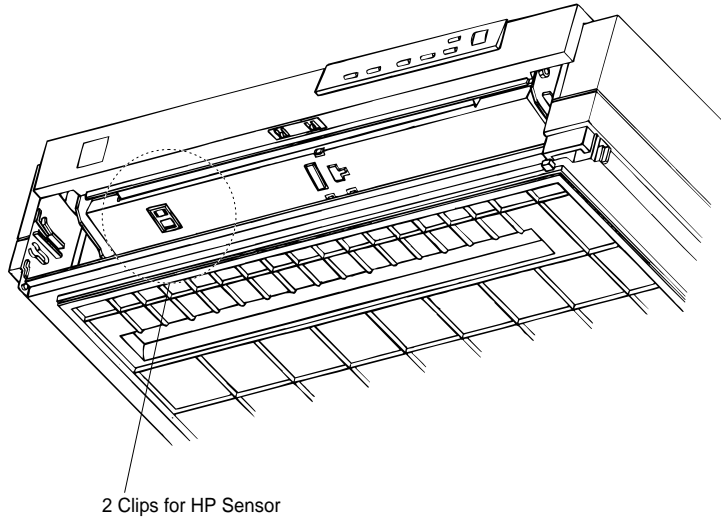

Figure 3-8 Removing the HP Sensor

Assembly Note

Notice the direction for mounting the HP sensor. Refer to the figure above.

3.2.5 Removing the PW Sensor Assembly

1. Remove the printer cover and ribbon cartridge (see Section 3.2.1).
2. Remove the CB screw (2.5 × 5, F/Zn) securing the PW sensor to the ribbon mask holder. Then, remove the FFC from the PW sensor connector, mounted onto the CR cover.
3. Remove the PW sensor assembly along with the CR cover by pushing and releasing the 2 clips for the CR cover, as shown in the following figure.

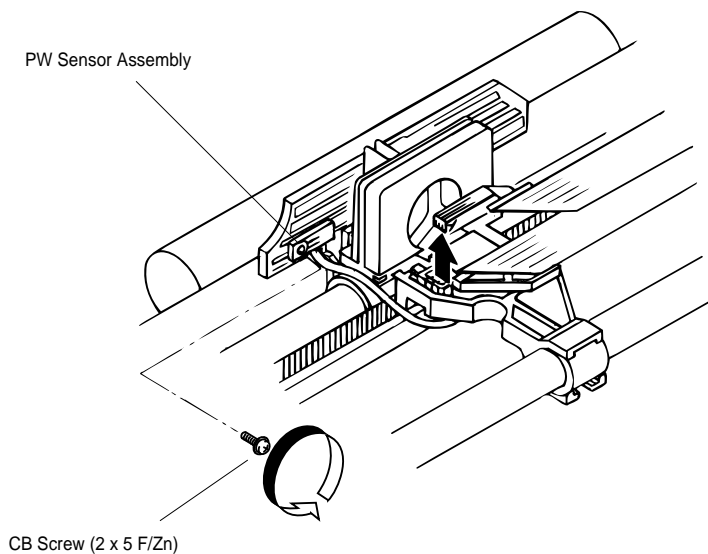

Figure 3-9 Removing the PW Sensor Assembly

Assembly Notes

Mount the PW sensor assembly onto the ribbon mask holder groove, aligning the bottom line of micro photo sensor to the bottom line of the groove.

Whenever you remove the PW sensor assembly, clean the surface of the sensor by wiping it with a soft material. If the surface is not clean, abnormal operations may occur, such as printing on the platen surface.

*The tightening torque for the CB screw (2.5 × 5, F/Zn) = 0.08 ~ 0.12 Nm (0.8 ~ 0.12 Kg f-cm)
When you replace the PW sensor assembly, reset the TPE level. Refer to Chapter 4.*

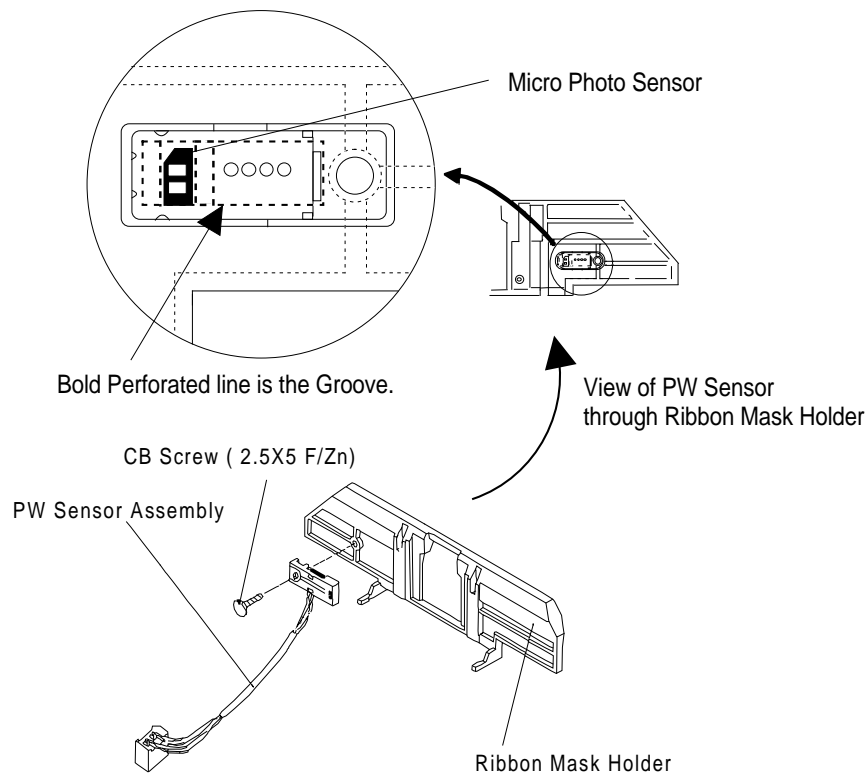

Figure 3-10 Mounting Position for the PW Sensor Assembly

3.2.6 Removing the Platen Assembly

1. Remove the printer cover, ribbon cartridge, and platen knob (see Section 3.2.1).
2. Release both locks for the left and right bushings (8 mm) by pushing the lever holder for the bushings outside, and then pulling the holder lever forward.

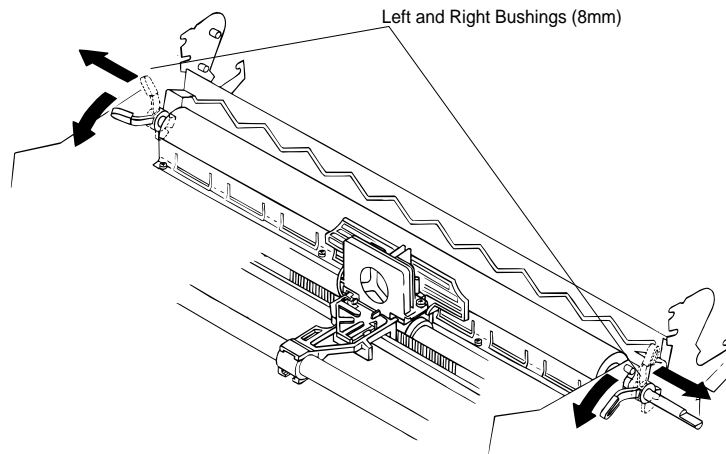

Figure 3-11 Releasing the Locks for the Bushings

3. Slide the platen assembly to the right, and move the printhead to the right edge.
4. Pull the left edge of the platen assembly upward by tilting it backward, and then pull up the right edge of the platen assembly.

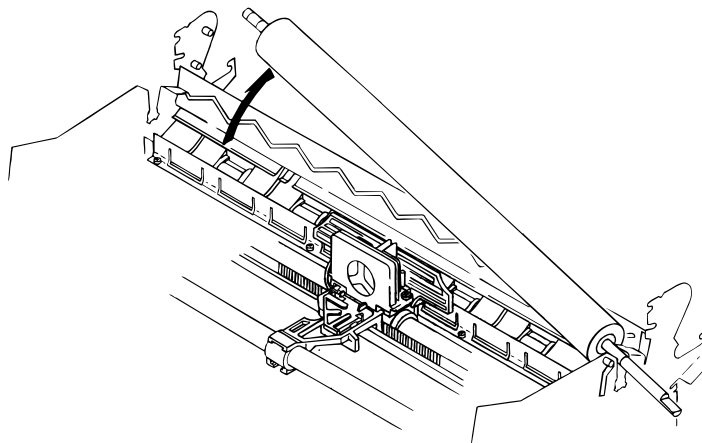

Figure 3-12 Removing the Platen Assembly

Assembly Notes

Before reinstalling the platen assembly into the printer mechanism, move the printhead to the right edge of the CR shaft, and set the release lever to the tractor position. This pre-assembly operation helps you mount the platen assembly more easily.

After installing the platen assembly into the printer mechanism, make sure both locks for left and right bushings (8 mm) are locked completely.

Be careful handling the lever holders for the left and right bushings (8 mm). These are fragile.

Adjust the platen gap. Refer to Chapter 4.

3.2.7 Removing the Upper Housing Assembly

- 1 Remove the rear edge guide assembly, paper eject assembly, rear tractor unit, and printer cover (see Section 3.2.1).
- 2 Remove the panel board assembly (see Section 3.2.2).
- 3 Remove 4 CBB screws (4×14 , F/Zn) securing the upper housing assembly.
- 4 Remove the platen knob.
- 5 Lift up the front side of the upper housing assembly by releasing 2 hooks from the holes located on right and left of the front bottom side.

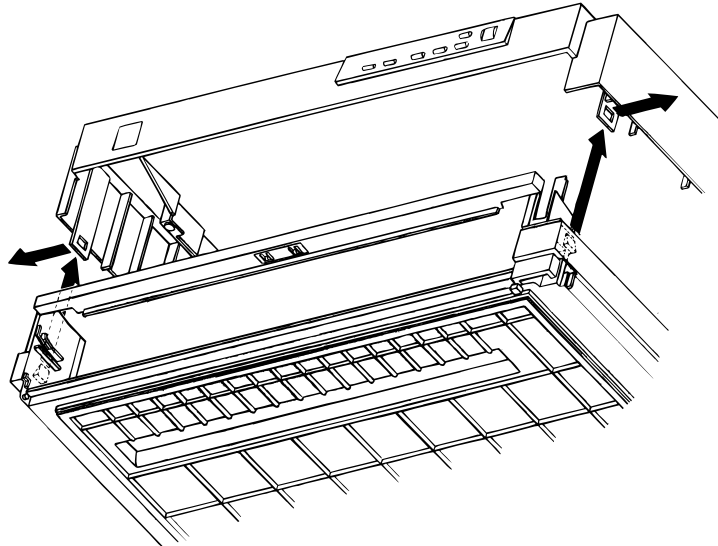

Figure 3-13 Releasing the Upper Housing Assembly Hooks

- 6 Remove the upper housing assembly.

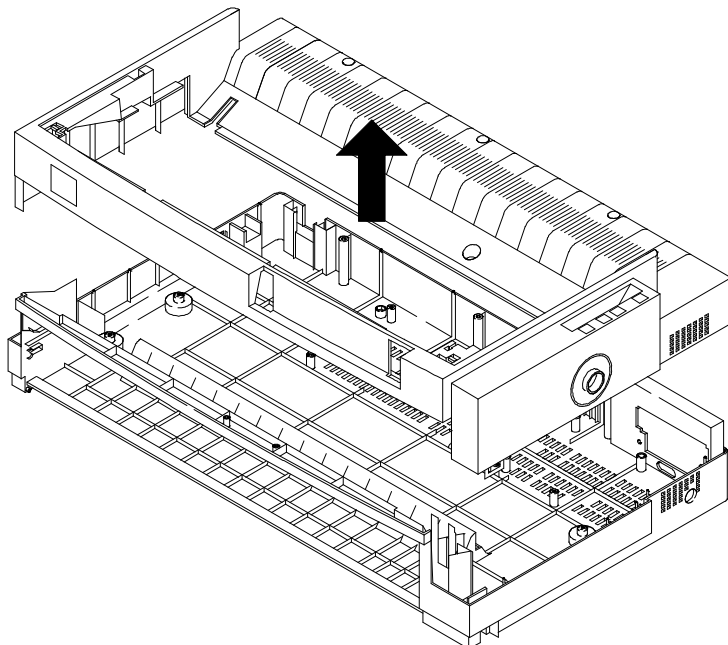

Figure 3-14 Removing the Upper Housing Assembly

Assembly Note

The tightening torque for the CBB (4×14 , F/Zn) = 0.98 Nm (10 ~ 12 Kg - cm)

3.2.8 Removing the Case Open Sensor Assembly

1. Remove the rear edge guide assembly, paper eject assembly, rear tractor unit, and printer cover (see Section 3.2.1).
2. Remove the panel board (see Section 3.2.2) and upper housing assemblies (see Section 3.2.7).
3. Turn the upper housing assembly over and remove the case open sensor assembly by loosening the CBB screw (3×8 , F/Zn) fixing the sensor holder to the upper housing assembly.

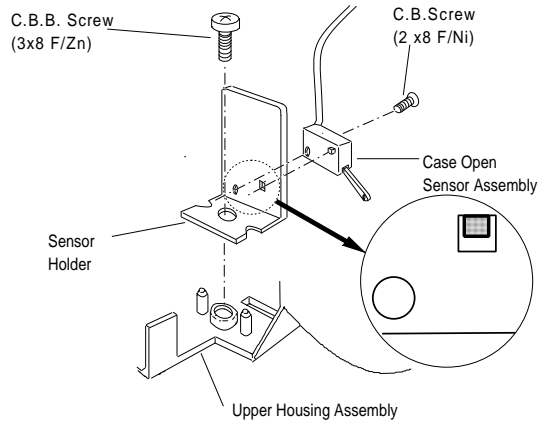

Figure 3-15 Removing the Case Open Sensor Assembly

3.2.9 Removing the CR Motor Assembly

1. Remove the rear edge guide assembly, paper eject assembly, rear tractor unit, and printer cover. (see Section 3.2.1).
2. Remove the panel board (see Section 3.2.2) and upper housing assemblies (see Section 3.2.7).
3. Remove the 2 CR mounting screws securing the CR motor assembly. After releasing the extension spring (15.7 g), disengage the timing belt from the CR motor assembly.
4. Disconnect the cable for CN11 from the C165 MAIN board assembly.
5. Remove the CR motor assembly from the printer mechanism.

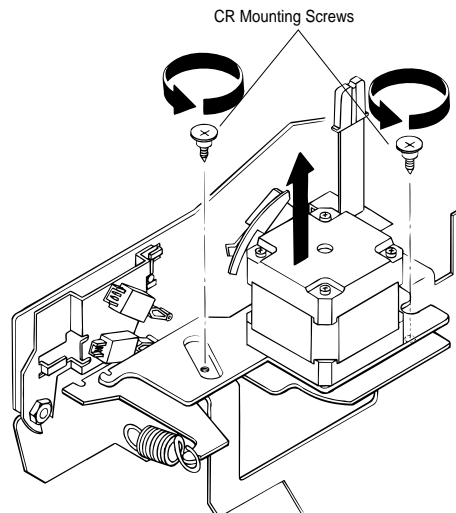

Figure 3-16 Removing the CR Motor Assembly

Assembly Notes

The tightening torque for the 2 CR mounting screws = 0.78 ~ 0.98 Nm (8~10 Kg - cm)

Adjust the bidirectional print alignment. Refer to Chapter 4.

3.2.10 Removing the Printer Mechanism

1. Remove the rear/front edge guide assembly, front cover, paper eject assembly, rear/front tractor units, and printer cover (see Section 3.2.1).
2. Remove the panel board assembly (see Section 3.2.2) and upper housing assembly (see Section 3.2.7).
3. Remove 4 printer mechanism mounting screws securing the printer mechanism.
4. Disconnect the following connectors on the C165 MAIN board assembly:

CN4 (3-pin, white)	CN5 (3-pin, black)	CN6 (2-pin, white)
CN7 (4-pin, white FFC)	CN8 (18-pin, white FFC)	CN9 (16-pin, white FFC)
CN10 (4-pin, blue)	CN11 (5-pin, blue)	CN12 (4-pin, white)
CN13 (2-pin, black)		

* Disconnect the cables for CN10 and CN11 after releasing the connector locks by pulling up.
5. Remove the printer mechanism.

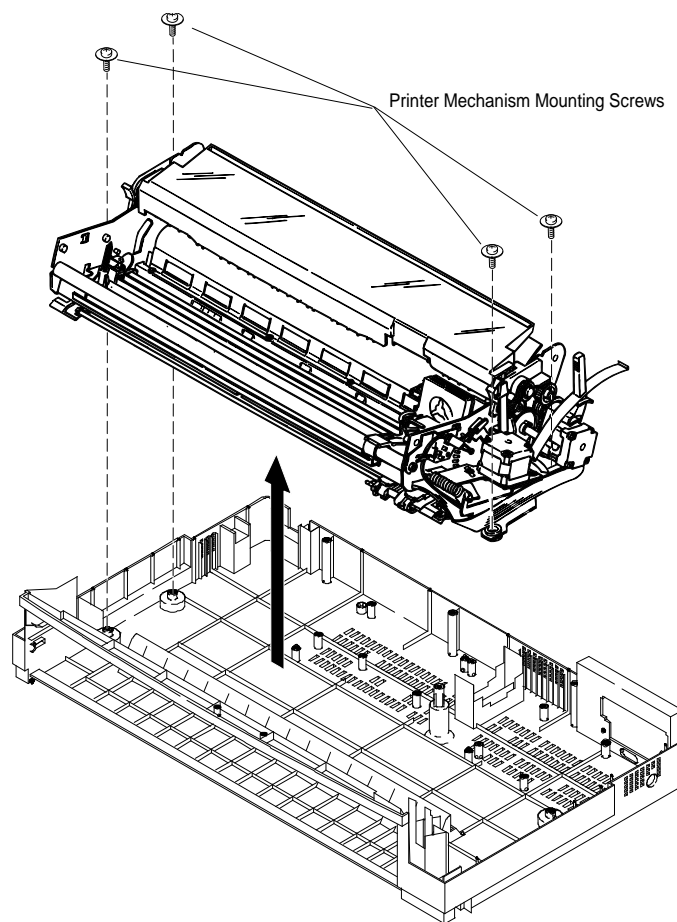

Figure 3-17 Removing the Printer Mechanism

Assembly Notes

Notice the connection for cables CN10 and CN11 and align the red colored cable to pin 1 of the connector.

*The tightening torque for the printer mechanism mounting screw =
0.98 Nm ~ 1.18 Nm (10 ~ 12 Kg - cm)*

Adjust the bidirectional print alignment and reset the TPE level. Refer to Chapter 4.

3.2.10.1 Removing the PF Motor

1. Remove the rear/front edge guide assembly, front cover, paper eject assembly, rear/front tractor unit, and printer cover (see Section 3.2.1).
2. Remove the panel board (see Section 3.2.2) and upper housing assemblies (see Section 3.2.7).
3. Remove the printer mechanism (see Section 3.2.10).
4. Remove the CBS screw (3×6 , F/Zn) and CB screw (3×8 , F/Zn) securing the PF motor.
5. Disconnect connector CN10 from the C165 MAIN board assembly.
6. Remove the PF motor from the right sub frame.

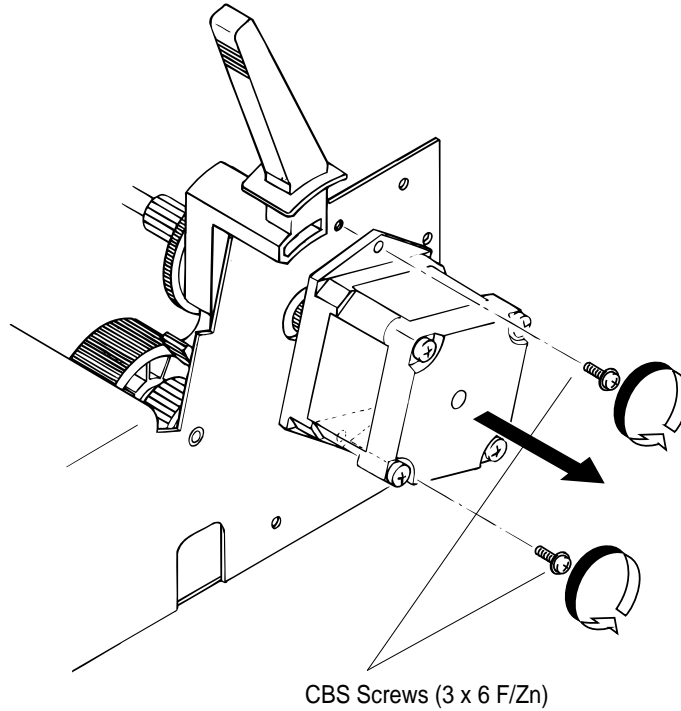

Figure 3-18 Removing the PF Motor

Assembly Note

Before attaching the PF motor to the proper position on the right sub frame, set the release lever to the full release position.

The CB screw (3×8 , FZ/n) is used to secure the upper part of the PF motor. The CBS screw (3×6 , FZ/n) is used to secure the lower part of the PF motor.

The tightening torque for the CB and CBS screws (3×8 , F/Zn) = 0.78 ~ 0.98 Nm (8 ~ 10 Kg - cm)

3.2.10.2 Removing the PG Sensor Assembly

1. Remove the rear/front edge guide assembly, front cover, paper eject assembly, rear/front tractor unit, and printer cover (see Section 3.2.1).
2. Remove the panel board (see Section 3.2.2) and upper housing assemblies (see Section 3.2.7).
3. Remove the printer mechanism (see Section 3.2.10).
4. Remove the hexagon nut (standard, M4) securing the PG sensor assembly to the right frame assembly.

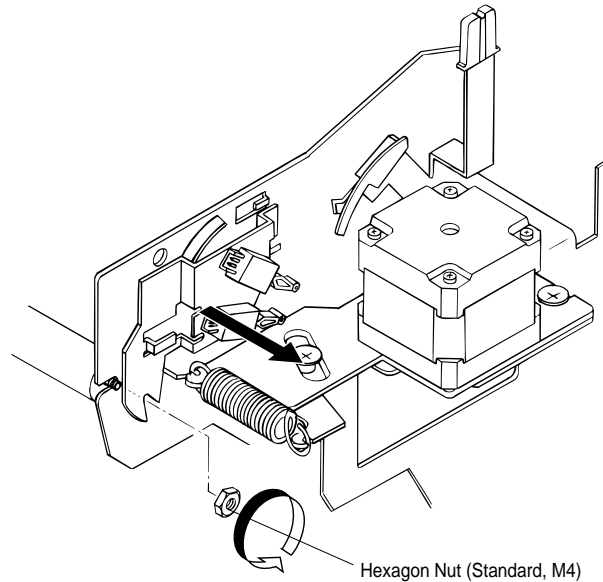

Figure 3-19 Removing the PG Sensor Assembly

Assembly Notes

The tightening torque for the hexagon nut (standard, M4) = 1.18 ~ 1.37 Nm (12 ~ 14 Kg f - cm)

When securing the shaft, push the front CR guide shaft to the bottom of the cutout.

3.2.10.3 Removing the Right Frame Assembly

1. Remove the rear/front edge guide assembly, front cover, paper eject assembly, rear/front tractor unit, and printer cover (see Section 3.2.1).
2. Remove the panel board (see Section 3.2.2) and upper housing assemblies (see Section 3.2.7).
3. Remove the printer mechanism (see Section 3.2.10), CR motor assembly (see Section 3.2.9), PF motor, (see Section 3.2.10.1) and PG sensor assembly (see Section 3.2.10.2).
4. Remove the hexagon nut (standard, M4) securing the gap adjust lever. Then, remove the gap adjust lever from the right frame assembly.
5. Remove 2 CBS screws (3 × 6, F/Zn) securing the platen cover.
6. Remove 3 CBS screws (3 × 6, F/Zn) securing the right frame assembly at the positions illustrated.

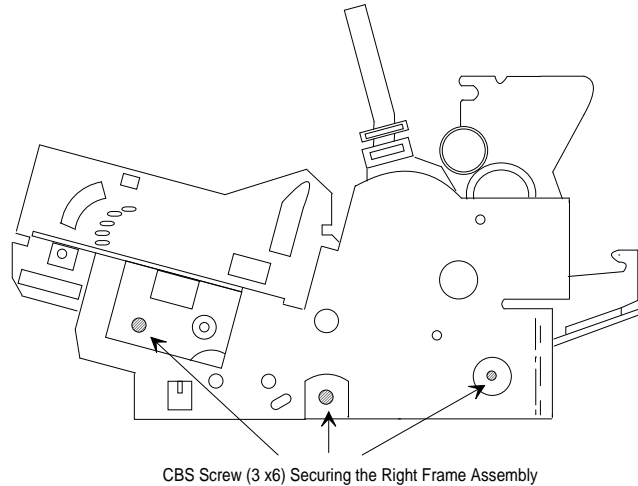

Figure 3-20 Removing the Right Frame Assembly

7. Remove the right frame assembly.

Assembly Notes

Adjust the platen gap and bidirectional print alignment. Refer to Chapter 4.

3.2.10.4 Disassembling the Right Frame Assembly

1. Remove 1 CBS screw (3 × 6, F/Zn) and 1 CBS screw (3 × 8, F/Zn) securing the right sub frame. (The bold line in the illustration is the right sub frame.)

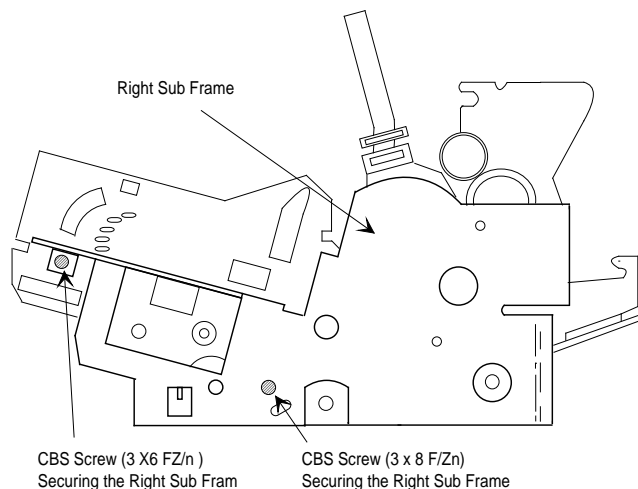

Figure 3-21 Removing the Right Sub Frame

2. Remove the right sub frame from the right frame assembly.
3. Remove the following 11 parts from the right frame assembly.

2 compression springs (200 g)	2 plain washers	1 spur gear (27 mm)
2 spur gears (34.5 mm)		1 spur gear (34 mm) 1 spur gear (21 mm)
1 combination gear (8 mm, 31.5 mm)		1 intermittent gear

Assembly Notes

Adjust the bidirectional print alignment. Refer to Chapter 4.

Mount the 11 parts above on the right frame assembly, as shown in the following figures.

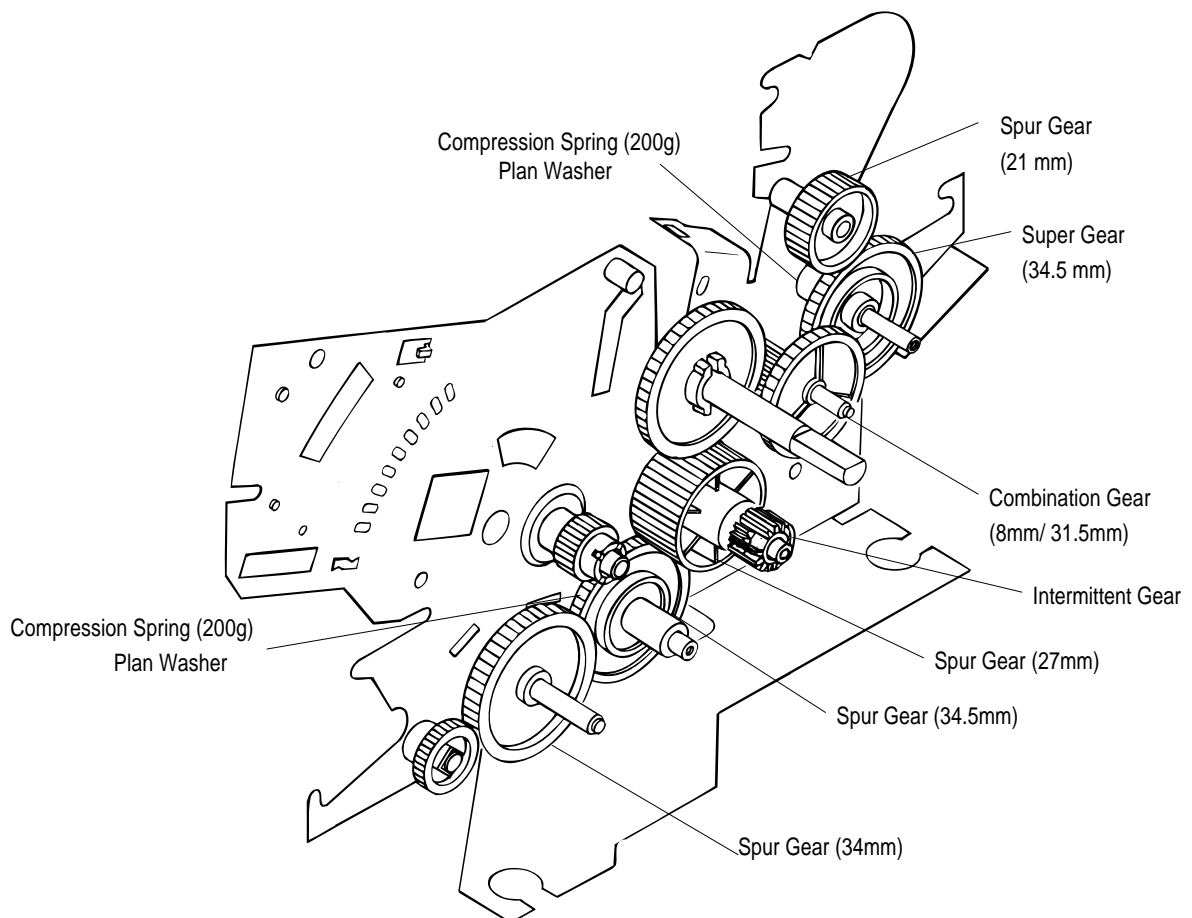

Figure 3-22 Engaging Gears 1

Assembly Notes

When you engage the release lever and release lever transmission to the tractor clutch cam, notice the points in the following figure.

The tightening torque for the CBS screws (3×6 , F/Zn) and (3×8 , F/Zn)
 $0.78 \sim 0.98 \text{ N.m}$ ($8 \sim 10 \text{ Kg - cm}$)

The tightening torque for the hexagon nut (standard, M4) =
 $1.18 \sim 1.37 \text{ N.m}$ ($12 \sim 14 \text{ Kg f - cm}$)

Notice how the intermittent gear, release lever, and release lever transmission are engaged.

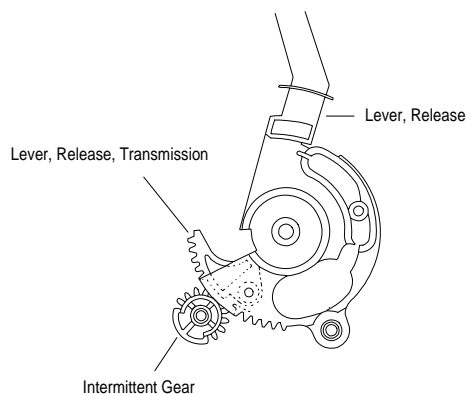

Figure 3-23 Engaging Gears 2

Pay attention to how the tractor clutch cam is engaged. Refer to the following figure.

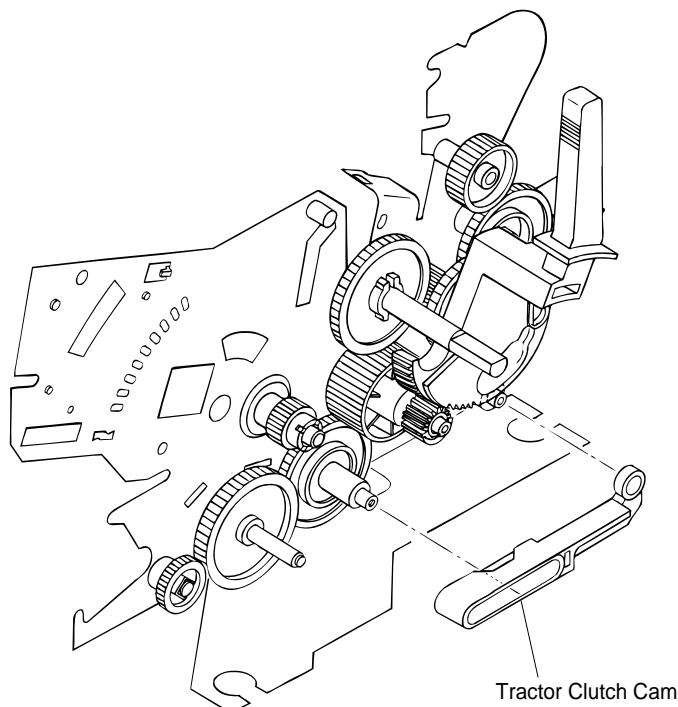

Figure 3-24 Engaging the Tractor Clutch Cam

3.2.10.5 Removing the Left Frame Assembly

1. Remove the rear/front edge guide assembly, front cover, paper eject assembly, rear/front tractor unit, and printer cover (see Section 3.2.1).
2. Remove the panel board assembly (see Section 3.2.2), upper housing assembly (see Section 3.2.7), and then remove the printer mechanism (see Section 3.2.10).
3. Remove 2 CBS screws (3×6 , F/Zn) securing the platen cover.
4. Remove the hexagon nut (standard, M4) securing the front CR guide shaft and left frame.
5. Remove 4 CBS screws (3×6 , F/Zn) securing the left frame assembly.

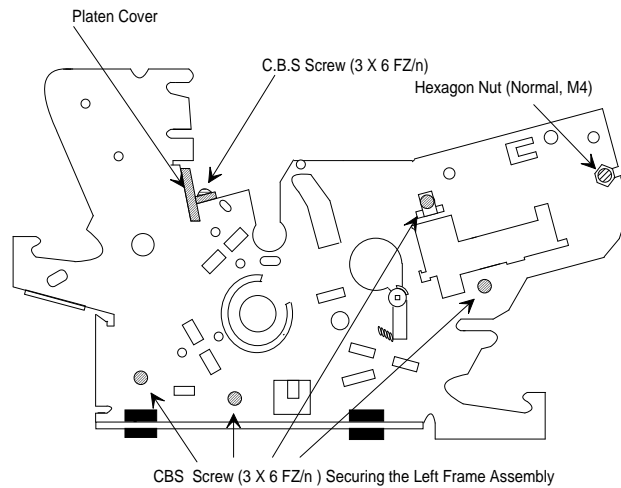

Figure 3-25 Removing the Left Frame Assembly

6. Disconnect 2 connector cables from the 2 release lever sensors, and then disconnect the connector cable from the HP sensor.
7. Remove the left frame assembly.

Assembly Notes

Notice the connection of the release lever sensor cables. The white connector's cable should be connected to the SW1 sensor, as shown in the following figure.

The tightening torque for the CBS screw (3×6 , F/Zn) = $0.78 \sim 0.98 \text{ Nm}$ ($8 \sim 10 \text{ Kg f - cm}$)

The tightening torque for the hexagon nut (standard, M4) = $1.18 \sim 1.37 \text{ Nm}$ ($12 \sim 14 \text{ Kg f - cm}$)

Adjust the platen gap and bidirectional print alignment. Refer to Chapter 4.

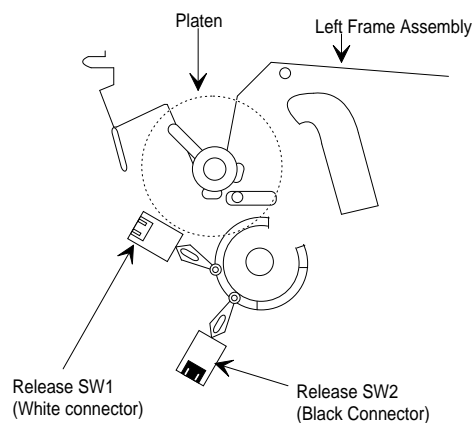

Figure 3-26 Cable Connections for the Release Lever Sensors

3.2.10.6 Removing the Ribbon Drive (RD) Assembly

1. Remove the rear/front edge guide assembly, front cover, paper eject assembly, rear/front tractor unit, and printer cover (see Section 3.2.1).
2. Remove the panel board (see Section 3.2.2) and upper housing assemblies (see Section 3.2.7).
3. Remove the printer mechanism (see Section 3.2.10).
4. Remove the left frame assembly (see Section 3.2.10.5).
5. Remove 2 CBS screws (3×8 , F/Zn) securing the RD assembly to the front frame.
6. Remove the RD assembly from the front frame.
7. Remove the timing belt from the RD assembly.

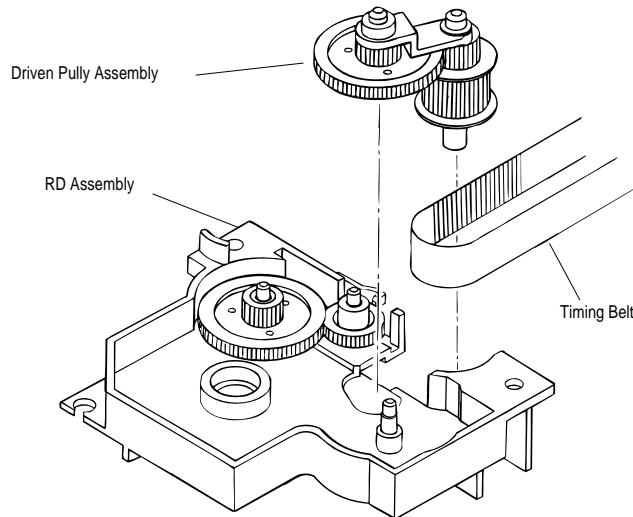

Figure 3-27 Removing the RD Assembly

Assembly Notes

Notice how the gears in the RD assembly are engaged. Refer to the following figure.

The tightening torque for the CBS screw (3×8 , F/Zn) = $0.78 \sim 0.98 \text{ N.m}$ ($8 \sim 10 \text{ Kg-cm}$)

Adjust the platen gap and perform the bidirectional print alignment. See Chapter 4.

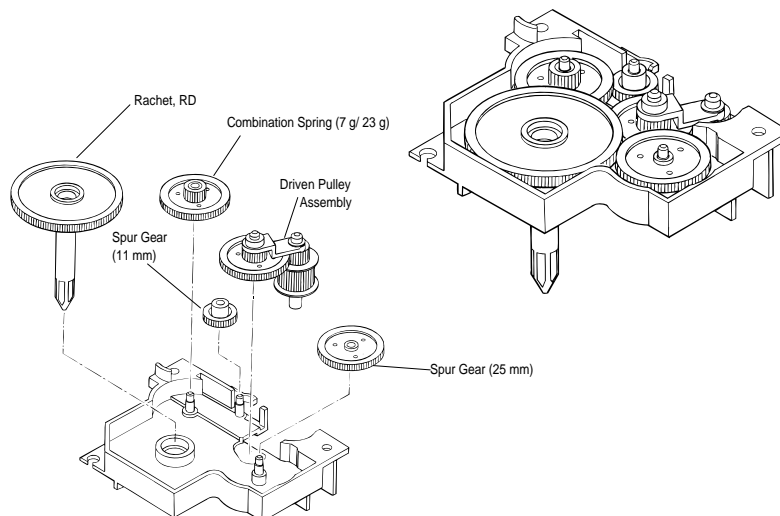

Figure 3-28 Engaging Gears for the RD Assembly

3.2.10.7 Removing the CR Assembly

1. Remove the rear/front edge guide assembly, front cover, paper eject assembly, rear/front tractor unit, and printer cover.
2. Remove the panel board (see Section 3.2.2) and upper housing assemblies (see Section 3.2.7).
3. Remove the printer mechanism (see Section 3.2.10).
4. Remove the left frame assembly (see Section 3.2.10.5) and RD assembly (see Section 3.2.10.6).
5. Disconnect 3 FFCs from the printhead and PW sensor assembly.

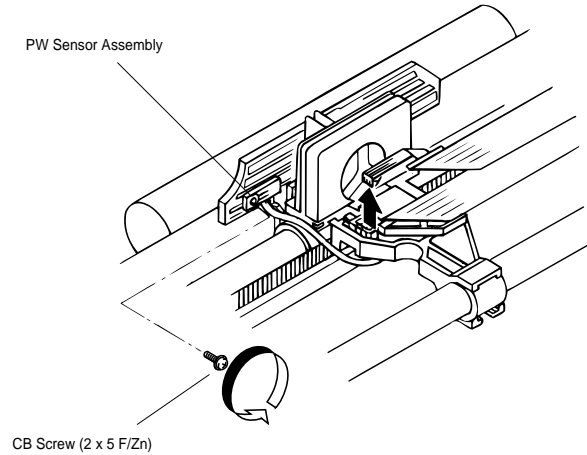

Figure 3-29 Disconnecting the FFCs

6. Disengage the timing belt from the CR motor pinion gear.
7. Remove the CR assembly from the rear/front CR guide shaft.

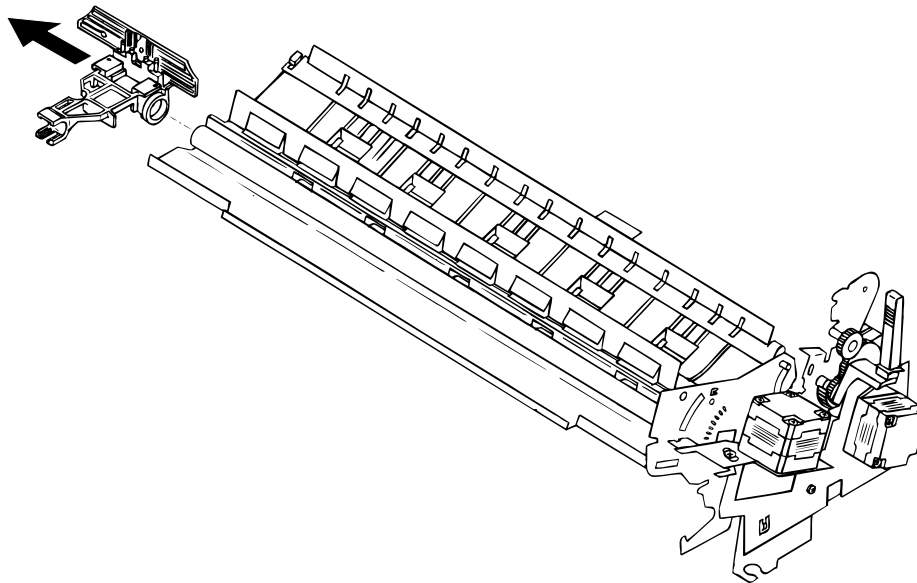

Figure 3-30 Removing the CR Assembly

8. Remove the timing belt from the 2 holding slots under CR assembly.
9. Remove the CR assembly.

Assembly Note

Adjust the platen gap and the bidirectional print alignment. Refer to Chapter 4.

Assembly Notes

Insert the timing belt properly into the 2 holding slots at the bottom of the CR assembly. Take up the timing belt slack between the two slots completely, as shown in the following figure.

Insert the 2 oil pads into the proper positions in the CR assembly, as shown.

If you remove the rear CR guide shaft along with the CR assembly, be sure to reinstall the rear CR guide shaft in the printer mechanism. The rear CR guide shaft has been drilled through the shaft near the right edge, and one side of the hole has a chamfered edge. This edge should be up.

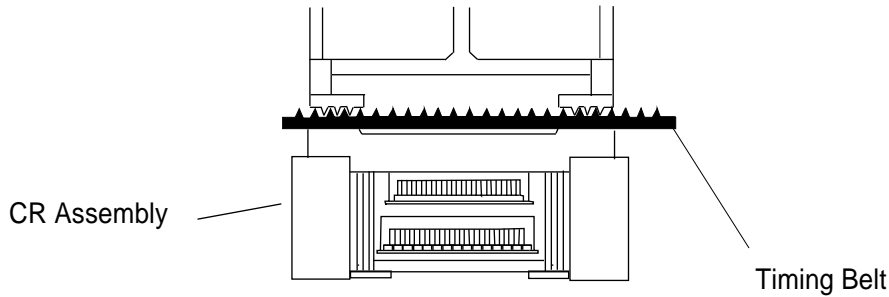

Figure 3-31 Inserting the Timing Belt

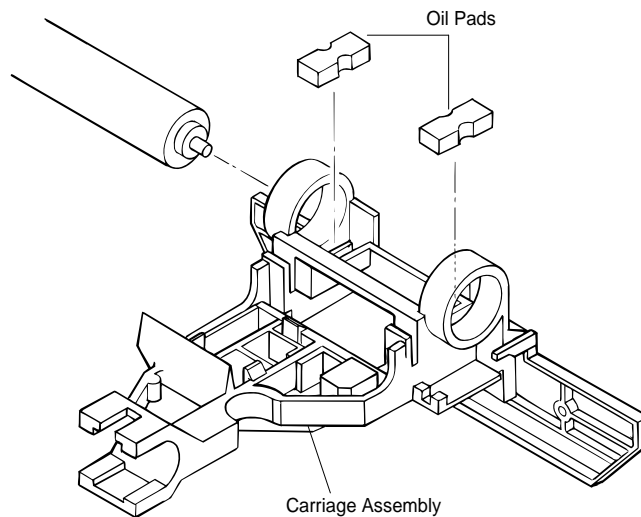

Figure 3-32 Installing the Oil Pad in the CR Assembly

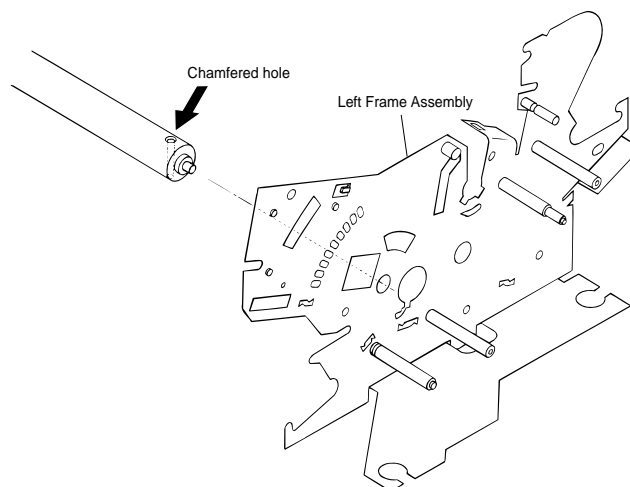

Figure 3-33 Assembling the Rear CR Guide Shaft

3.2.10.8 Removing the Rear PE Sensor Assembly

- 1 Remove the rear/front edge guide assembly, front cover, paper eject assembly, rear/front tractor unit, and printer cover.
- 2 Remove the panel board (see Section 3.2.2) and upper housing assemblies (see Section 3.2.7).
- 3 Remove the printer mechanism (see Section 3.2.10).
- 4 Turn the printer mechanism over, and insert a standard screwdriver or other prying tool into hole in the rear frame shown in the figure.
- 5 Release 2 clips while pushing up the rear PE sensor with the screwdriver or other prying tool.

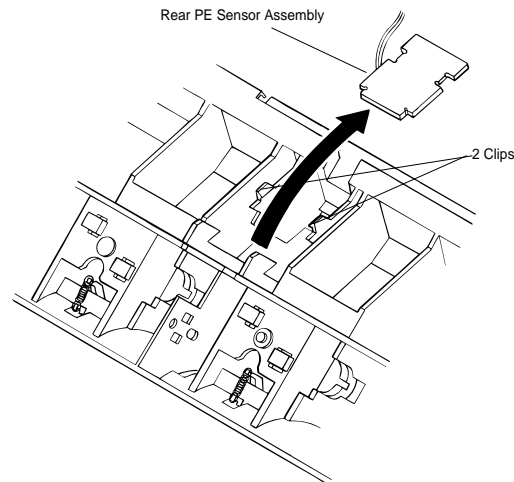

Figure 3-34 Removing the Rear PE Sensor Assembly

- 6 Remove the rear PE sensor after disconnecting the connector.

3.2.10.9 Removing the Front PE Sensor Assembly

- 1 Remove the rear/front edge guide assembly, front cover, paper eject assembly, rear/front tractor unit, and printer cover.
- 2 Remove the panel board (see Section 3.2.2) and upper housing assemblies (see Section 3.2.7).
- 3 Remove the printer mechanism (see Section 3.2.10).
- 4 Turn the printer mechanism over on the reverse side and remove the front PE sensor by pushing and releasing the 2 clips.

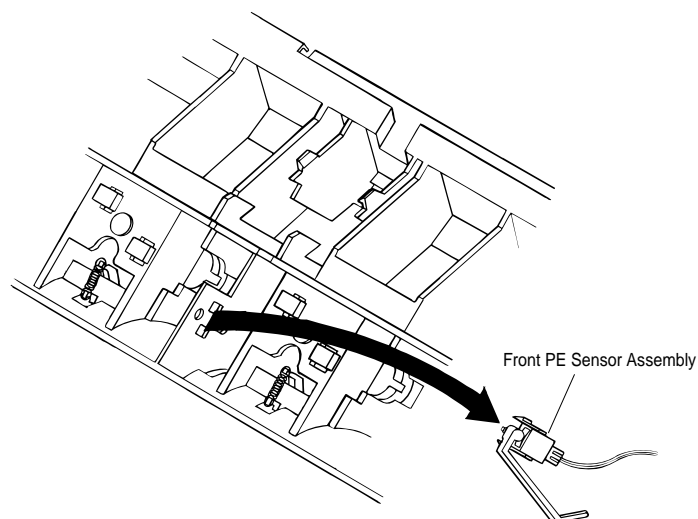

Figure 3-35 Removing the Front PE Sensor Assembly

3.2.11 Removing the C165 MAIN Board Assembly

1. Remove the rear/front edge guide assembly, front cover, paper eject assembly, rear/front tractor unit, and printer cover (see Section 3.2.1)
2. Remove the panel board (see Section 3.2.2) and upper housing assemblies (see Section 3.2.7).
3. Disconnect the following connectors from the C165 MAIN board assembly.

CN3 (12-pin , blue)	CN4 (3-pin, white)	CN5 (3-pin, black)
CN6 (2-pin, white)	CN7 (4-pin, white FFC)	CN8 (18-pin, white FFC)
CN9 (16-pin, white FFC)	CN10 (4-pin, blue)	CN11 (5-pin, blue)
CN12 (4-pin, white)	CN13 (2-pin, black)	CN15 (22-pin FFC)

 - ※ Disconnect the cables for CN10 and CN11 after releasing the connector lock.
 - ※ Disconnect the cable for CN3 by pushing down the connector lock.
4. Remove the 2 CBS screws (3 × 12, F/Zn) securing the upper connector cover.
5. Remove 5 CBB screws (3 × 12, F/Zn) and 1 CBC lamitate screw (3 × 8, F/Zn) securing the C165 MAIN board assembly to the lower housing assembly.
6. Remove the option I/F cage from the C165 MAIN board by releasing the hooks which is fixing it to the C165 MAIN board.

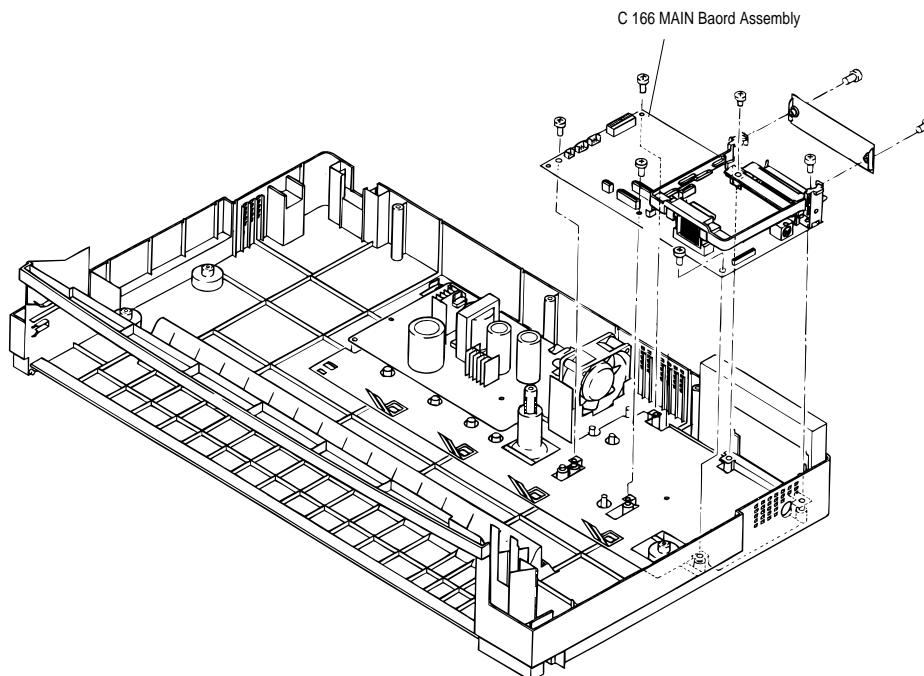

Figure 3-36 Removing the C165 MAIN Baord Assembly

7. Remove the C165 MAIN board assembly.

Assembly Notes

Notice the location of the CBC lamitate screw (3 × 8, F/Zn). Refer to the above figure.

Lock CN10 and CN11 by pushing down each connector's lock after inserting the connector cable.

The tightening torque for the CBB (3 × 12, F/Zn) screw = 0.78 ~ 0.98 Nm (8 ~ 10 Kg f - cm)

The tightening torque for CBB (3 × 8, F/Zn) screw = 0.78 ~ 0.98 Nm (8 ~ 10 Kg f - cm)

If you replace the main board, adjust the bidirectional print alignment and run the default setting program. Refer to Chapter 4.

3.2.12 Removing the C165 PSB/E Board Assembly

1. Remove the rear/front edge guide assembly, front cover, paper eject assembly, rear/front tractor unit, and printer cover.
2. Remove the panel board (see Section 3.2.2) and upper housing assemblies (see Section 3.2.7).
3. Remove the 5 CBB screws (3×12 , F/Zn) securing the C165 PSB/E board assembly.
4. Disconnect the cable for CN3 on the C165 MAIN board assembly.
5. Disconnect the cable for the fan motor from CN3 on the C165 PSB/E board assembly.
6. Remove the C165 PSB/E board assembly while pulling up the fan motor.

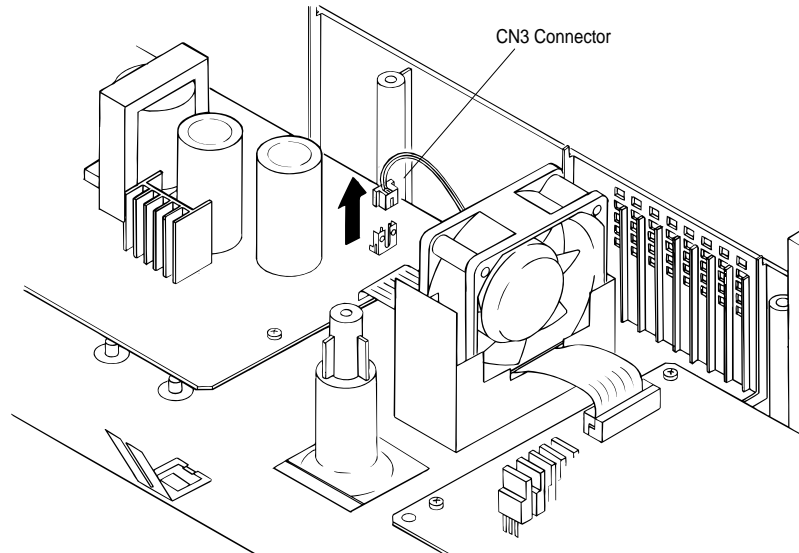

Figure 3-37 Removing the C165 PSB/E Board Assembly

Assembly Notes

Insert the cable for CN2 (C165 PSB/E board assembly side) under the fan motor.

The tightening torque for the CBB screw (3×12 , F/Zn) = 0.78 ~ 0.98 Nm (8 ~ 10 Kg - cm)

Notice the direction for mounting the fan motor. Refer to the following figure.

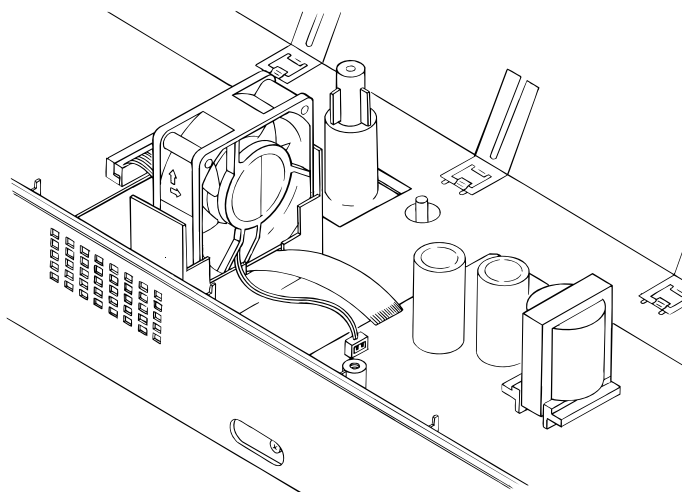

Figure 3-38 Direction for Mounting the Fan Motor

3.3. Disassembly and Assembly of CSF Bin 1

This section describes procedures for disassembling and assembling the optional cut sheet feeder. In general, you can install a component in the CSF simply by reversing the procedure for removing it. Therefore, this section does not describe assembly procedures in most cases. If necessary, special notes on assembling a component are given at the end of the description of each procedure.

3.3.1 Disassembling the Right Side Block

1. Remove the CSF gear cover by pushing and releasing the 4 clips in the following figure.

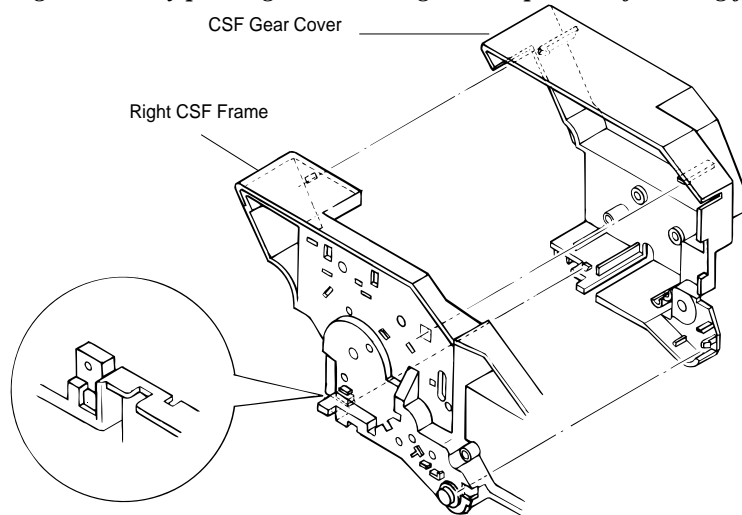

Figure 3-39 Releasing the Clips for the CSF Gear Cover

2. Remove the 3 CPB tight (3×12) screws securing the stepping motor to the right CSF frame.
3. Disconnect connector CN1 from the CSF board assembly, and then remove the stepping motor.
4. Remove the CPB tight (3×12) screw securing the CSF board assembly, and disconnect connector CN2.
5. Remove the CSF board assembly by releasing 1 clip fixing the CSF board assembly to the right CSF frame.
6. Remove the 13 gears mounted on the right CSF frame.

Assembly Notes

Be careful of the cable alignment for the CN1 connector cable and earth cables. Align those cables as shown in the following figure. If these cables is not aligned properly, the CSF gear cover cannot be assembled properly.

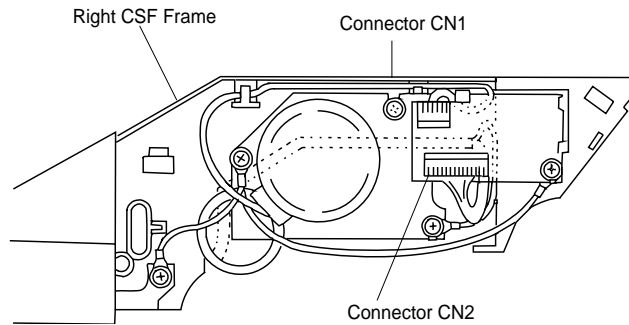

Figure 3-40 Cable Alignment

Use the following figure to assemble the 13 gears onto the right CSF frame.

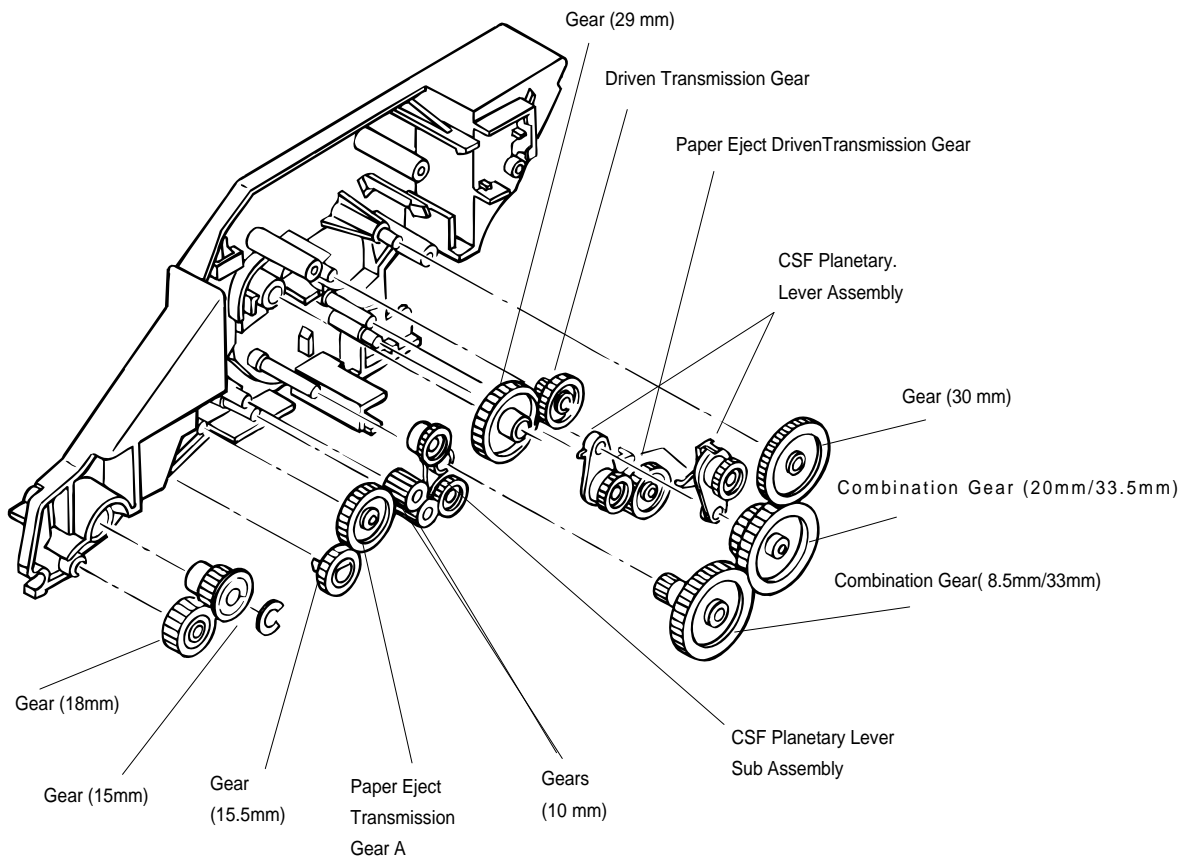

Figure 3-41 Engaging 13 Gears

3.3.2 Disassembling Paper Support Block Assembly

1. Remove the CSF gear cover. Refer to step 1 in Section 3.3.1.
2. Remove the stepping motor. Refer to steps 2 and 3 in the Section 3.3.1.
3. Remove the E-ring fixing the right edge of the paper feed shaft.

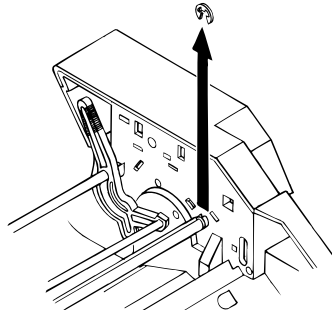

Figure 3-42 Removing the E-ring

4. Remove 1 gear (29 mm) from the right edge of the paper feed shaft.

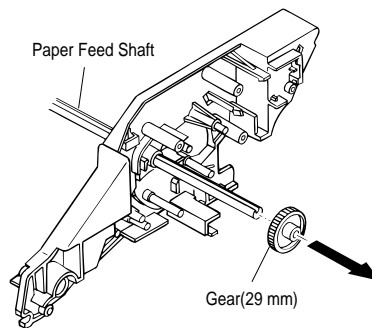

Figure 3-43 Removing 1 Gear (29mm)

5. Remove the paper feed shaft by pulling it toward the right side.
6. Remove the CPB tight (3 × 8) screw securing the paper support shaft to the right CSF frame, as shown in the following figure.

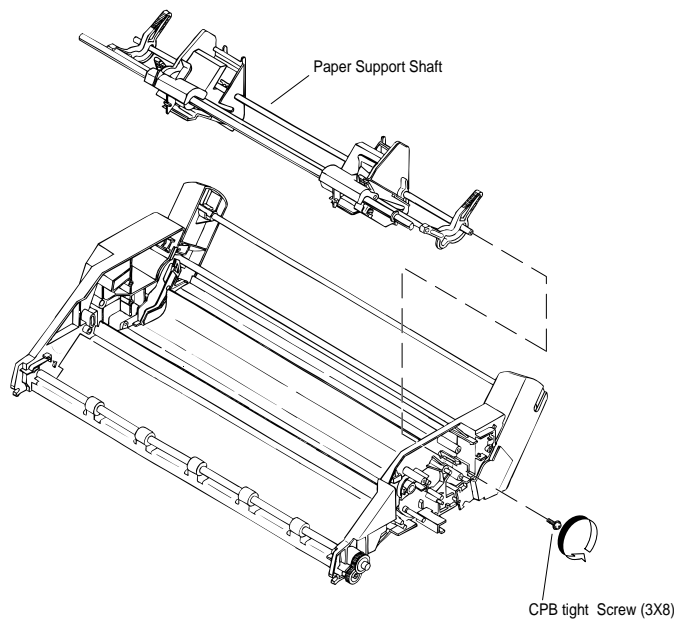

Figure 3-44 Removing the CBP Tight (3 x 8) Screw

7. Remove the paper support assembly along with the paper support shaft and paper shaft holder by pulling upward.

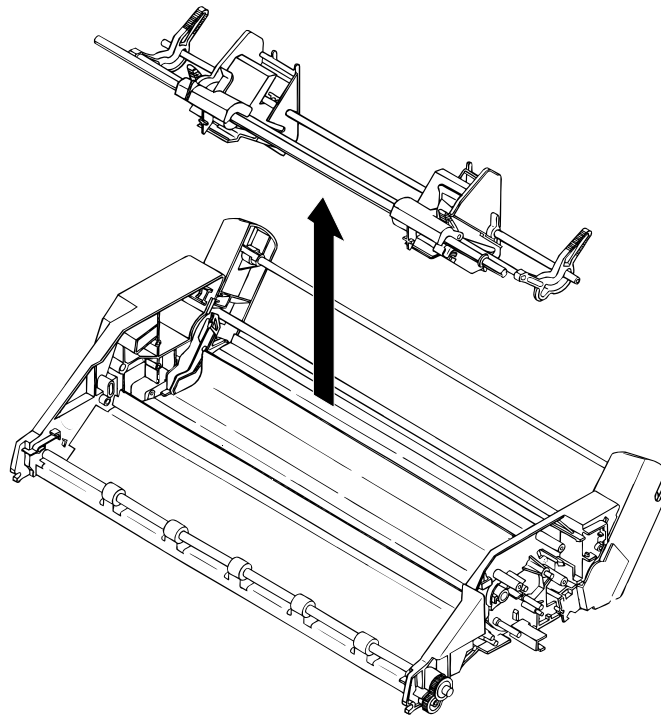

Figure 3-45 Removing the Paper Support Block Assembly

8. Remove both paper feed rollers from both paper support assemblies.
 9. Remove both paper loading roller cover assemblies by releasing the clips fixing them to the paper support assembly.

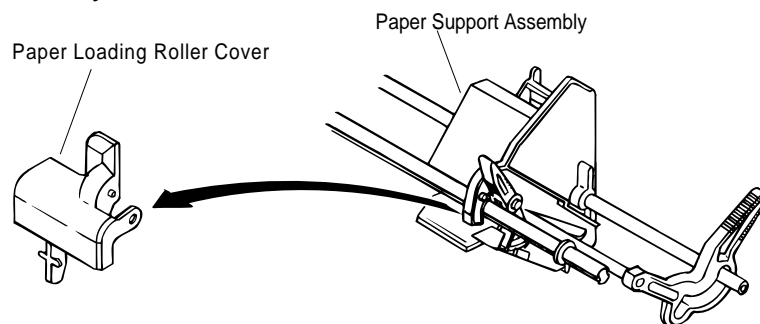

Figure 3-46 Removing the Paper Loading Roller Cover Assembly

10. Remove the paper support shaft by pulling it toward the right or left side.
 11. Remove the paper holder spring.

Assembly Note

Be sure to assemble the paper feed roller into the proper side. The right and left rollers are not interchangeable.

3.3.3 Removing the Paper Eject Assembly Cover

1. Remove the paper eject assembly cover by releasing 2 clips located along both edges of the paper eject assembly cover, as shown in the following figure.

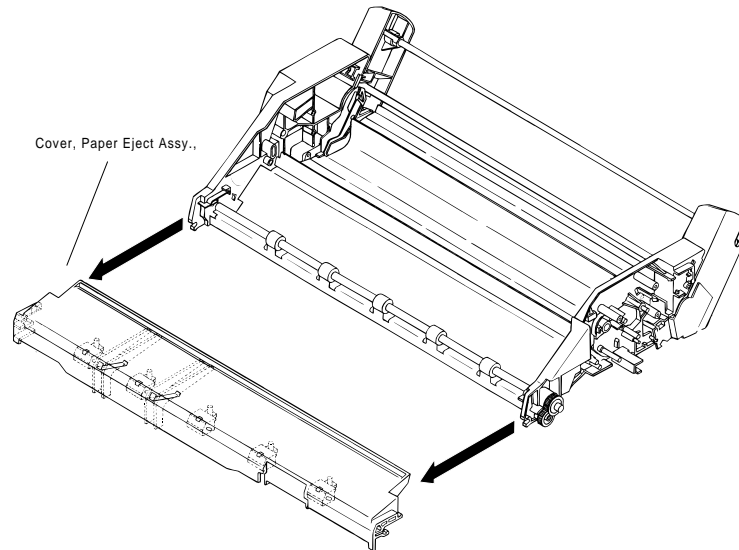

Figure 3-47 Removing the Paper Eject Assembly Cover

Assembly Note

When attaching the paper eject assembly cover to the CSF unit, pay attention to the position of 2 pieces of thin plastic film glued on the reverse side of the paper eject assembly cover, as shown in the following figure.

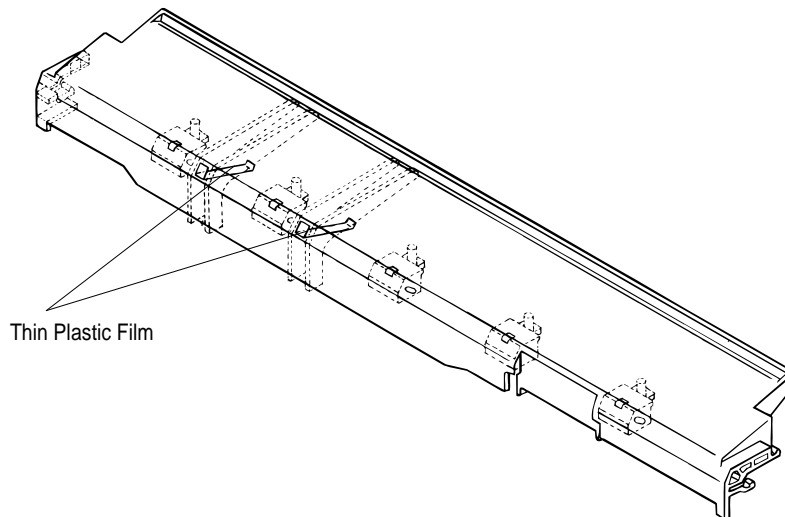

Figure 3-48 Assembling the Paper Eject Assembly Cover

3.4 Disassembly and Assembly of CSF Bin 2

3.4.1 Disassembling the Right Side Block

1. Remove the gear train cover by releasing the 4 clips shown in the following figure.

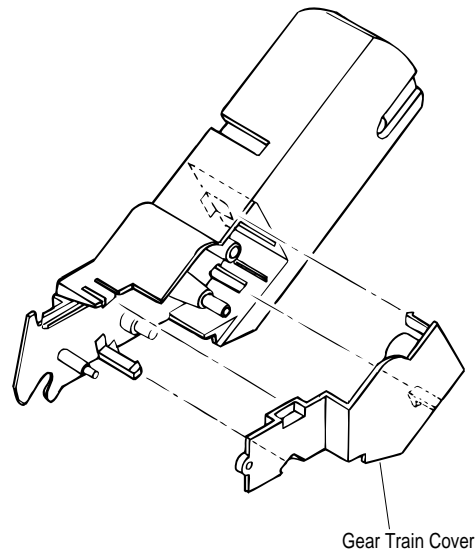

Figure 3-49 Removing the Gear Train Cover

2. Remove the following 5 gears and 1 spring from the right CSF frame.

Assembly Note

Pay attention how the 5 gears are engaged. Refer to the following figure.

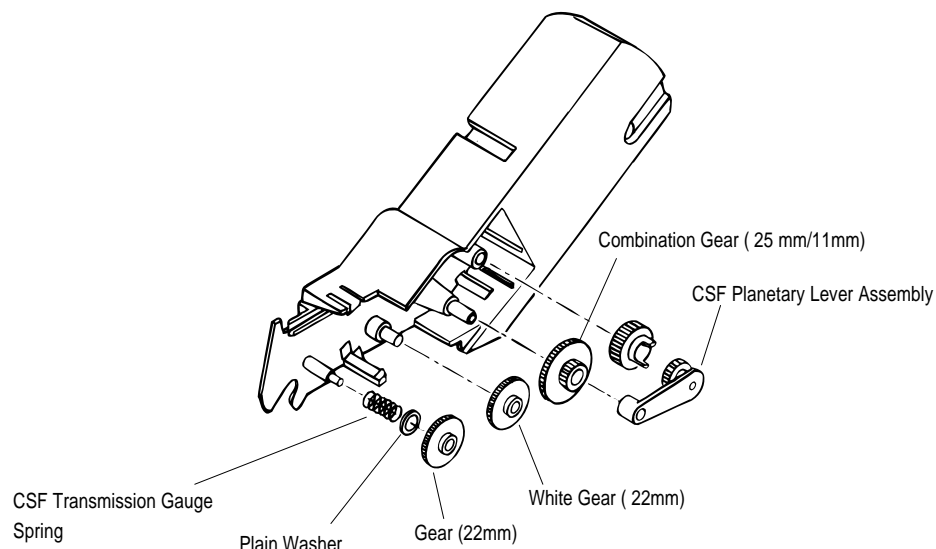

Figure 3-50 Engaging 5 Gears

3.4.2 Disassembling the Paper Support Block Assembly

1. Remove 1 E-ring fixing the paper feed roller shaft to the right CSF frame.
2. Remove 2 CTBS (3 × 8) screws securing the paper support shaft to both right and left CSF frames.

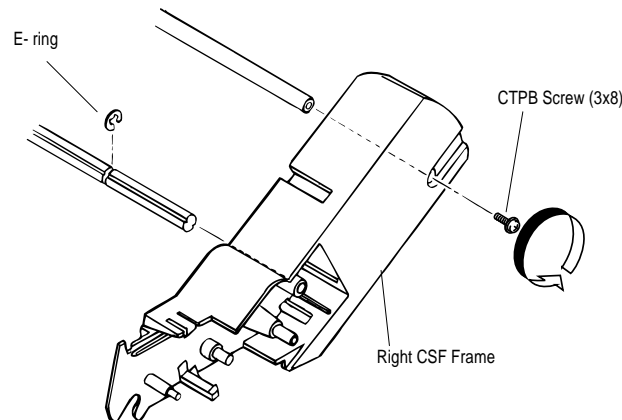

Figure 3-51 Removing 1 E-ring and 2 CTBS Screws

3. Remove both paper support assemblies along with the paper feed roller shaft and paper support shaft.
4. Remove the paper feed shaft from both paper support assemblies by pulling them toward the right or left side.
5. Remove both paper feed rollers from the paper support assemblies.
6. Remove both CSF roller covers by releasing the clips fixing them to the paper support assemblies.
7. Remove the paper support shaft by pulling out it toward the right or left side.

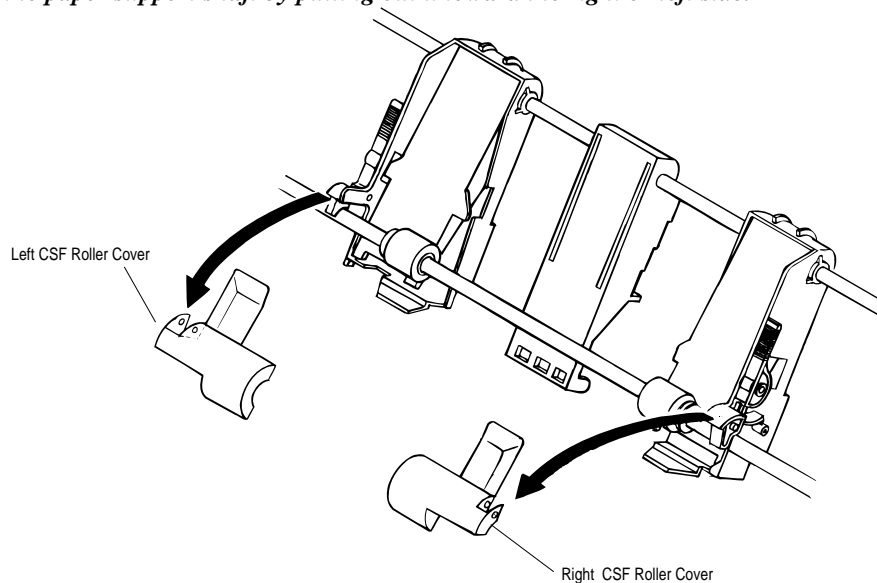

Figure 3-52 Removing the CSF Roller Cover

8. Remove the paper holder, and then remove the paper holder spring.

Assembly Note

Be careful to assemble the paper feed roller into the proper side of the paper support assembly. The right and left rollers are not interchangeable.

CHAPTER 4 Adjustments

Table of Contents

4.1 ADJUSTMENT OVERVIEW	4-1
4.1.1 Required Adjustments	4-1
4.1.2. Required Adjustment Tools	4-1
4.2 ADJUSTING AND RESETTING THE PRINTER	4-2
4.2.1 Platen Gap Adjustment	4-2
4.2.2 Bidirectional Print Alignment Adjustment	4-4
4.2.2.1 Bi-d Print Alignment Adjustment on the Settings Diskette	4-4
4.2.2.2 Bi-d Print Alignment Adjustment on the Control Panel	4-6
4.2.3 Factory Setting	4-7
4.2.4 TPE Level Reset	4-8

List of Figures

Figure 4-1. Removing the Ribbon Mask	4-2
Figure 4-2. Setting Position for PG Adjust Lever	4-2
Figure 4-3. Platen Gap	4-3
Figure 4-4. Adjusting the Parallelism of the CR Guide Shaft	4-3
Figure 4-5. Machine Select Menu	4-4
Figure 4-6. Setting File Menu	4-4
Figure 4-7. Main Menu	4-4
Figure 4-8. Bidirectional Adjustment Menu	4-5
Figure 4-9. Current Bi-d Print Alignment	4-5
Figure 4-10. Guide Sheet for Bi-d Adjustment	4-6
Figure 4-11. Machine Select Menu	4-7
Figure 4-12. Setting File Menu	4-7
Figure 4-13. Main Menu	4-7
Figure 4-14. Machine Select Menu	4-8
Figure 4-15. Setting File Menu	4-8
Figure 4-16. Manin Menu	4-8

Lists of Tables

Table 4-1. Required Adjustment	4-1
Table 4-2. Required Adjustment Tool	4-1

4.1 ADJUSTMENT OVERVIEW

4.1.1 Required Adjustments

This section describes what adjustments are required after any part is removed or replaced. The following table shows the relationship between the repaired item and the adjustment.

Table 4-1 Required Adjustments

Repaired Item \ Adjustment	Platen Gap	Bi-d Print Alignment	Factory Settings	TPE Level Reset
Printer Mechanism Replacement	— (* 1)	○ (* 2)	—	○
Main Board Replacement	—	○	○	—
EEPROM Replacement	—	○	○	—
PW Sensor Assembly Replacement	—	—	—	○
Platen Assembly Replacement or Removal	○	—	—	—
CR Motor Assembly Replacement or Removal	—	○	—	—
Right Frame Assembly Replacement or Removal	○	○	—	—
Right Frame Disassembly	—	○	—	—
Left Frame Replacement or Removal	○	○	—	—
RD Assembly Replacement or Removal	○	○	—	—
CR Assembly Replacement or Removal	○	○	—	—

(* 1): — means adjustment is not required.

(* 2): ○ means adjustment is required.

Note

When any part is replaced or reassembled, use the Check Program included on the Settings Diskette, and check the performance and settings of various check patterns.

4.1.2 Required Adjustment Tools

The following table shows the tools required for each adjustment.

Table 4-2 Required Adjustment Tools

Adjustment	Required Tool	Page
Platen Gap	Thickness Gauge (B776702201)	4-2
Bi-d Print Alignment	Settings Diskette (* 1) or Remote Utility or Panel Operation	4-4
Factory Settings (* 2)	Settings Diskette	4-7
TPE Level Reset	Settings Diskette	4-8

* 1: The Settings Diskette contains 3 settings programs: the bidirectional adjustment program, factory settings program, and TPE (top paper end) level rewrite. The diskette also includes 4 check programs: continuous form paper, A3 cut sheets, A4 cut sheets, and envelopes.

* 2: This factory settings program includes several factory setting items. Using this program sets the printer to the destination factory settings.

4.2 ADJUSTING AND RESETTING THE PRINTER

4.2.1 Platen Gap Adjustment

If you have rotated or reassembled the rear CR guide shaft or parallelism adjustment bushing, or if printing is light or dark, even at the proper PG lever position, perform this adjustment at 3 positions: the 5th, 80th, and 130th columns.

1. Remove the printhead from the CR assembly (see Section 3.2.3).
2. Remove the ribbon mask from the ribbon mask holder using tweezers, as shown in the figure.

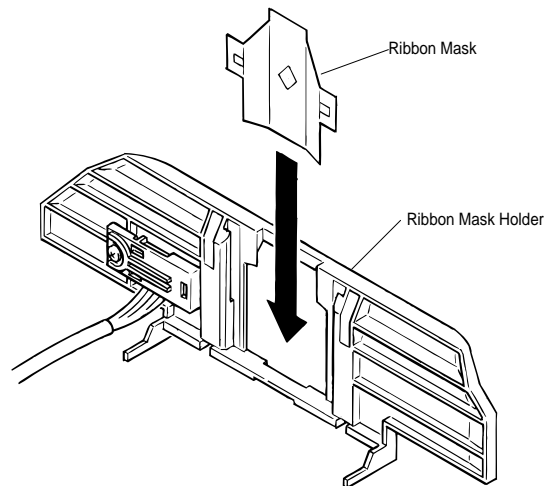

Figure 4-1 Removing the Ribbon Mask

3. Attach the printhead to the CR assembly again, tightening the 2 CBS screws (3 × 10, F/Zn).
4. Move the printhead to 5th column position.
5. Set the release lever to the FRICTION position.
6. Set the PG adjust lever to the second slot from rear of the printer mechanism as shown in the following illustration.
7. Loosen the hexagon nut (standard, M4) securing the PG adjust lever while setting the PG adjust lever to the second slot position from the rear of the printer mechanism.

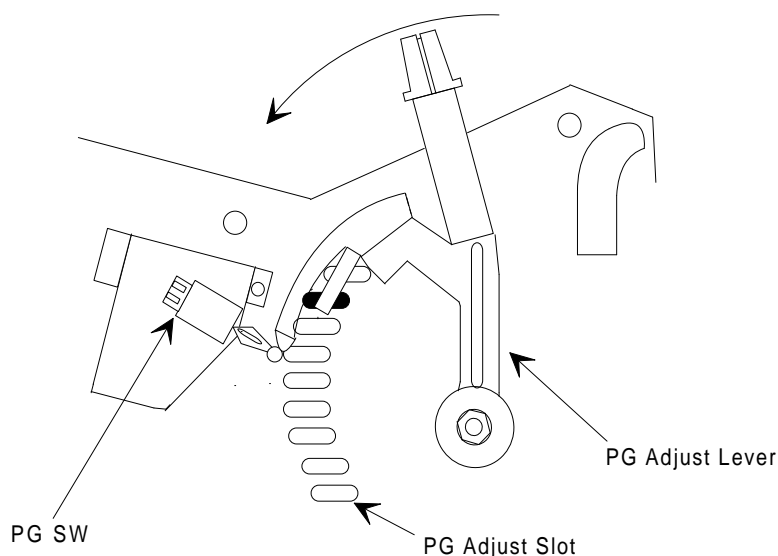

Figure 4-2 Setting the PG Adjust Lever

8. Insert the thickness gauge vertically between the printhead and platen.

9. Insert a thin screwdriver into the drilled hole, located at the right edge of the rear CR guide shaft and adjust the platen gap by moving the screwdriver to forward or backward until the gap is large enough for a 0.36 mm thickness gauge but too narrow for a 0.40 mm thickness gauge.
10. When the gap is correct at the 5th column, check the platen gap at the 80th, and then the 130th column positions.

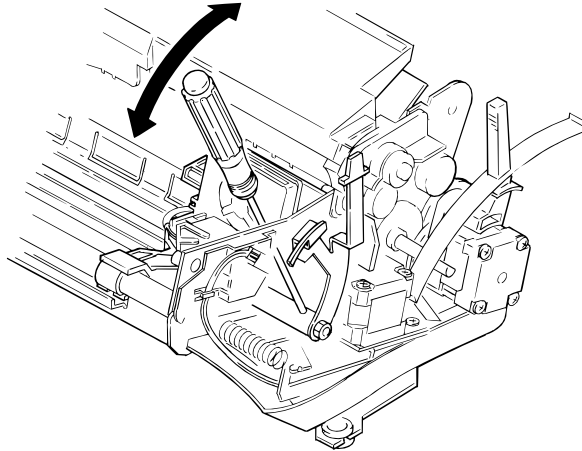

Figure 4-3 Platen Gap

11. If the platen gap is wider at the 5th column than the 130th column, adjust the parallelism for the rear CR guide shaft by moving the parallelism adjustment bushing backward. If the platen gap is more narrow for the 5th column than the 130th column, adjust the parallelism of the CR guide shaft by moving the parallelism adjustment bushing forward. Refer to the following figure.

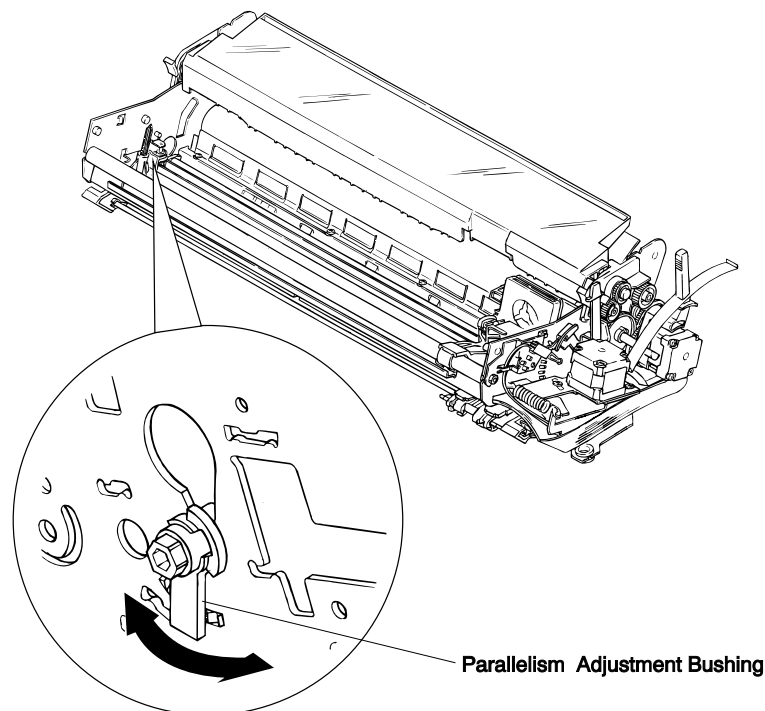

Figure 4-4 Adjusting the Parallelism of the CR Guide Shaft

12. Continue performing adjustment steps 8 to 11 until the platen gap is correct at all 3 positions. After completing the adjustment, remove the screwdriver from the rear CR guide shaft.
13. After inserting the ribbon mask in the ribbon mask holder and installing the printhead into CR assembly, tighten the 2 CBS screws ($3 \times 8, F/Zn$) to attach the printhead.
14. Tighten the hexagon nut (standard, M4) securing the PG adjust lever.

4.2.2 Bidirectional Print Alignment Adjustment

This section describes the procedure for adjusting the bidirectional print alignment, required after mechanism repair. This procedure is also necessary if you replace the main board assembly or EEPROM, because the adjusted value is written to the EEPROM on the C165 MAIN board. You can perform the adjustment from the Settings Diskette, using the control panel, or with a remote utility. This section describes the adjustment procedure with the Settings Diskette first, and then describes the adjustment procedure using the control panel.

- Notes:**
- When the main board is replaced, reset the Factory Settings first, then perform the bidirectional adjustment.
 - Do not perform the Bi-d adjustment if the input voltage is fluctuating heavily.

4.2.2.1 Bi-d Print Alignment Adjustment using the Settings Diskette

1. Insert the Settings Diskette into Drive A of the PC and the power on.
2. Type **GW BASIC** and press **ENTER**.
3. Load and run the **J10A00E** program. First, the program displays Machine Select Menu.

```

Program : J10A00E      Setting : DEFSTD
9 pins  VR 0 = 0      VR 1 = 0      VR 2 = 0

[ Printer select ]
> (1) 9 pins
(2) 24 pins

```

Figure 4-5 Machine Select Menu

Note: DEFSTD is the default U.S. setting.

4. Highlight **24 pins** by moving the cursor with \uparrow or \downarrow key and select it by pressing **ENTER**.
5. After you select **24 pins**, you see the following menu.

```

Program : J10A00E      Setting : DEFSTD
9 pins  VR 0 = 0      VR 1 = 0      VR 2 = 0

[ Setting File ]
> (1) DEFSTD
(2) EURSTD
(3) NLSP
(4) ITALIC
(5) RUSSIAN

```

Figure 4-6 Setting File Menu

6. In this menu, highlight the factory settings for the printer's destination by moving the cursor with the \uparrow or \downarrow key and select the destination factory settings by pressing **ENTER**.
7. After you select the each factory settings, the program displays the Main Menu, shown below.

```

Program : J10A00E      Setting : DEFSTD
9 pins  VR 0 = 0      VR 1 = 0      VR 2 = 0

[ Main MENU ]
> (1) Bi-d Adjust      (6) TPE LEVEL RESET
(2) Check Pro. (FF)
(3) Check Pro. (A3)
(4) Check Pro. (A4)
(5) Check Pro. (Envelope)

```

Figure 4-7 Main Menu

8. Highlight **Bi-d Adjust** by moving the cursor with the \uparrow or \downarrow key and select it by pressing **ENTER**.
9. After you select **Bi-d Adjust**, the program displays the Bi-D Adjustment Menu, shown on the next page.
10. Highlight the mode by moving the cursor with the \uparrow or \downarrow key, and then print the current Bi-d print alignment pattern for that mode by pressing **SPACE**.

4.2.2.2 Bi-d Print Alignment Adjustment from the Control Panel

1. Turn the printer on while pressing the **PAUSE** button to put the printer into Bi-D adjustment mode.
2. The printer prints out a guide sheet, containing 25 patterns in Super Draft mode.
3. Look for the pattern most closely aligned on the sheet.

To adjust your printer, follow these steps

1. Look for the alignment pattern that is most closely alignment and press the Pitch button until the lights indicate the appropriate pattern number as shown below.
2. Press the Font switch to resister your selection. The printer prints additional pages that display alignment patterns.
3. When you have made your last selection (sheet LQ), turn the printer off.

Pattern number	Pitch LEDs
1	■ ■ ■
2	■ ■ □
3	■ ■ □
4	■ □ ■
5	■ □ □
6	■ □ □
7	■ □ □
8	■ □ □
9	■ □ □
10	□ ■ ■
11	□ ■ □
12	□ ■ □
13	□ ■ □
	□ □ ■
14	□ □ □
15	□ □ □
16	□ □ ■
17	□ □ □
18	□ □ □
19	□ ■ ■
20	□ ■ □
21	□ ■ □
22	□ □ ■
23	□ □ □
24	□ □ □
25	□ □ ■

Super Draft

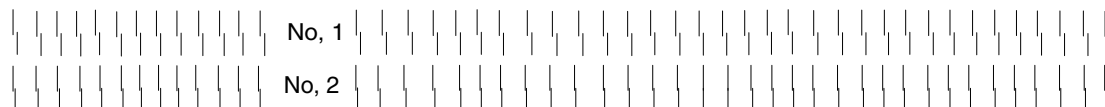

Figure 4-10 Guide Sheet for Bi-d Adjustment

4. Press the **PITCH** button until the lights match those for the best-aligned pattern on the guide sheet.
5. Press the **FONT** button to save your selection. The printer then prints 25 patterns in Draft print mode on the additional pages.
6. Return to step 3 of this procedure to adjust the bidirectional alignment in Draft mode.
7. After you perform steps 3 to 5 above for Draft mode, go back to step 3 to adjust NLQ mode.
8. When you have made your last selection in NLQ mode, turn the printer off to finish the adjustment.

4.2.3 Factory Settings

This section describes the procedure to reset factory settings, which is necessary if the main board or EEPROM is replaced. You can perform this procedure only with the Settings Diskette.

Notes: • After you select factory settings in the Setting File menu, be sure to run the check program in the Main Menu. Running the check program writes the selected factory settings to the EEPROM and prints several check patterns.

1. Insert the Settings Diskette into Drive A of the PC and turn PC power on.
2. Type **GW BASIC**, and press **ENTER**.
3. Load and run the **J10A00E** program. The program displays the Machine Select Menu shown below.

```

Program : J10A00E      Setting : DEFSTD
9 pins  VR 0 = 0      VR 1 = 0      VR 2 = 0

      [ Printer select ]
> (1) 9 pins
   (2) 24 pins

```

Figure 4-11 Machine Select Menu

4. In this menu, highlight **24 pins** by moving the cursor with the \uparrow or \downarrow key and select it by pressing **ENTER**.
5. After you select **24 pins**, the Setting File menu is shown.

```

Program : J10A00E      Setting : DEFSTD
9 pins  VR 0 = 0      VR 1 = 0      VR 2 = 0

      [ Setting File ]
> (1) DEFSTD
   (2) EURSTD
   (3) NLSP
   (4) ITALIC
   (5) RUSSIAN

```

Figure 4-12 Setting File Menu

6. In this menu, highlight the destination factory settings by moving the cursor with \uparrow or \downarrow key and select the destination factory settings by pressing **ENTER**.
7. After you select the factory settings, the program displays the Main Menu.

```

Program : J10A00E      Setting : DEFSTD
9 pins  VR 0 = 0      VR 1 = 0      VR 2 = 0

      [ Main MENU ]
(1) Bi-d Adjust      (6) TPE LEVEL RESET
> (2) Check Pro. (FF)
   (3) Check Pro. (A3)
   (4) Check Pro. (A4)
   (5) Check Pro. (Envelope)

```

Figure 4-13 Main Menu

8. In this menu, select one of the check programs, from 2 to 5, depending on the paper loaded, run that check program to print out check patterns. Running the check program writes the selected factory settings to EEPROM.
9. To exit the program, press **ESC** until the display returns to the MS-DOS prompt.

4.2.4 TPE Level Reset

This section describes the procedure to reset the TPE (top paper end) level. This operation is required when the PW sensor assembly is replaced, and if it is not performed, the printer does not recognize that the PW sensor has been replaced, thus, limiting the ability of the new sensor to operate. This reset operation can be performed only from the Settings Diskette.

Note: • After this operation, the reset value for the TPE LEVEL is printed out automatically. Check that the reset value is **FF**.

1. Insert the Settings Diskette into Drive A of the PC, and turn the power on.
2. Type **GWBASIC** and press **ENTER**.
3. Load and run the **J10A00E** program. First, the Machine Select Menu is displayed.

```
Program : J10A00E      Setting : DEFSTD
9 pins  VR 0 = 0     VR 1 = 0     VR 2 = 0
```

```
[ Printer select ]
> (1) 9 pins
(2) 24 pins
```

Figure 4-14 Machine Select Menu

4. In this menu, highlight **24 pins** by moving the cursor with \uparrow or \downarrow key, and select it by pressing **ENTER**.
5. After you select **24 pins**, the Setting File menu is displayed.

```
Program : J10A00E      Setting : DEFSTD
9 pins  VR 0 = 0     VR 1 = 0     VR 2 = 0
```

```
[ Setting File ]
> (1) DEFSTD
(2) EURSTD
(3) NLSP
(4) ITALIC
(5) RUSSIAN
```

Figure 4-15 Setting File Menu

6. In this menu, highlight the destination factory settings by moving the cursor with \uparrow or \downarrow key, and select the factory settings by pressing **ENTER**.
7. After you select the factory settings, the Main Menu is displayed.

```
Program : J10A00E      Setting : DEFSTD
9 pins  VR 0 = 0     VR 1 = 0     VR 2 = 0
```

```
[ Main MENU ]
(1) Bi-d Adjust      > (6) TPE LEVEL RESET
(2) Check Pro. (FF)
(3) Check Pro. (A3)
(4) Check Pro. (A4)
(5) Check Pro. (Envelope)
```

Figure 4-16 Main Menu

8. In this menu, highlight **TPE LEVEL RESET** by moving the cursor with \uparrow or \downarrow key and select it by pressing **ENTER**. This operation prints the reset value of the TPE LEVEL automatically. The reset value should be **FFH**. Check that the reset value is **FFH**.
9. To exit the program, press **ESC** until the display returns to the MS-DOS prompt.

CHAPTER 5 Troubleshooting

Table of Contents

5.1 OVERVIEW	5-1
5.2 TROUBLESHOOTING INFORMATION	5-1
5.2.1 PRINTHEAD	5-1
5.2.2 SENSORS	5-2
5.2.3 MOTORS	5-3
5.2.4 ERROR CODES WITH THE INDICATORS AND BUZZER	5-3
5.3 UNIT LEVEL TROUBLESHOOTING	5-4
5.4 REPAIRING THE C165PSB/PSE BOARD ASSEMBLY	5-10
5.5 REPAIRING THE C165 MAIN BOARD ASSEMBLY	5-12
5.6 REPAIRING THE PRINTER MECHANISM	5-15

List of Figures

Figure 5-1. Printhead Connector Pin Alignment	5-1
Figure 5-2. Flowchart — 1	5-5
Figure 5-3. Flowchart — 2	5-6
Figure 5-4. Flowchart — 2-1	5-7
Figure 5-5. Flowchart — 3	5-8
Figure 5-6. Flowchart — 4	5-9

List of Tables

Table 5-1. Printhead Coil Resistance Test Points	5-1
Table 5-2. Sensor Test Points	5-2
Table 5-3. Motor Test Points	5-3
Table 5-4. Indicators and Buzzer	5-3
Table 5-5. Symptoms and Problem Descriptions	5-4
Table 5-6. Repairing the C165 PSB/PSE Board Assembly	5-10
Table 5-7. Repairing the C165 MAIN Board Assembly	5-12
Table 5-8. Repairing the Printer Mechanism	5-15

5.1 OVERVIEW

This chapter contains flowcharts and checkpoint tables to help you troubleshoot the printer. Flowcharts let you isolate a faulty unit based on abnormal symptoms. The checkpoint tables let you identify the faulty part or unit by checking the values or ranges listed for each component.

5.2 TROUBLESHOOTING INFORMATION

This section gives troubleshooting information to let you check test points for replaceable units.

5.2.1 Printhead

5-1. Printhead Coil Resistance Test Points

Common Pin No.	Test Pin No.	Test Method <i>(Set meter to ohms. Disconnect the printhead after the printer is powered off.)</i>	Meter Reading
<i>Refer to the following figure.</i>	Refer to the following figure.	Place one lead on each pin and the other lead on each common pin.	$16.4 \pm 10\% \Omega$ <i>(at 25° C, 77° F)</i>

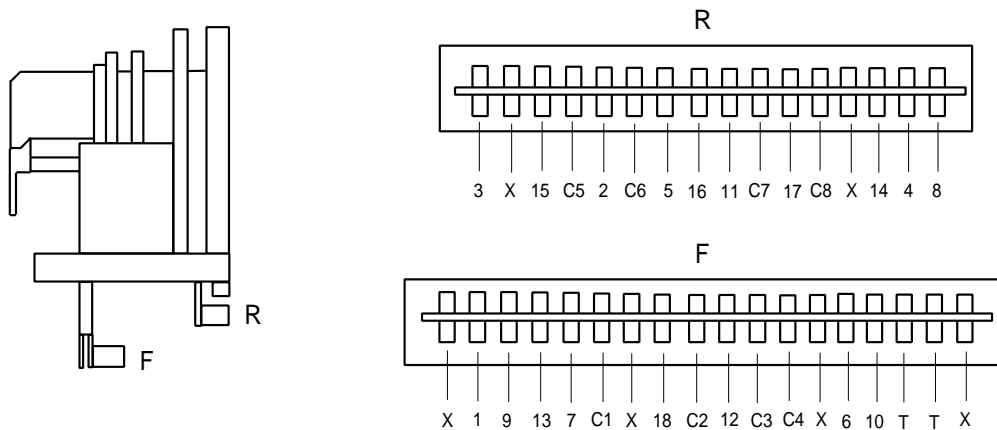

F				
COM.	C1	C2	C3	C4
Pin No,	1.7.13	9	10.18	6.12

R				
COM.	C5	C6	C7	C8
Pin No,	2.5.11	3.15	16.17	4.8.14

T : Thermistor terminal
X : Not used

Figure 5-1 Printhead Connector Pin Alignment

5.2.2 Sensors

Table 5-2 Sensor Test Points

<i>Sensor Connector Number</i>	<i>Test Pin Number</i>	<i>Test Method (Set Meter to DC Voltage.)</i>	<i>Meter Reading</i>	
<i>CN4 (HP Sensor)</i>	1: HP	Place one lead on pin 1 and the other lead on pin 2, and check the voltage while blocking the two sensor terminals.	Open: +5 V (Home position) Short: 0 V (Not home)	
	^		2: GND	^
	^		3: +5 V	^
<i>CN5 (Rear PE Sensor)</i>	1: +5 V	Place one lead on pin 2 and the other lead on pin 3, and check the voltage while toggling the sensor lever.	Open: +5 V (Paper loaded) Short: 0 V (No paper)	
	^		2: PE	^
	^		3: GND	^
<i>CN6 (Front PE Sensor)</i>	1: PE	Place one lead on pin 1 and the other lead on pin 2, and check the voltage while toggling the sensor lever.	Open : +5 V (Paper loaded) Short: 0 V (No paper)	
	^		2: GND	^
<i>CN13 (PG Sensors)</i>	1: PG 1	Place one lead on pin 1 and the other lead on pin 2 and check the voltage while toggling the sensor lever.	Open: +5 V Short: 0 V	
	^		2: GND	^
<i>CN12 (Release Sensors 1 and 2)</i>	1: Release 1	Place one lead on pin 1 and the other lead on pin 2, and check the voltage while toggling the sensor lever. Place one lead on pin 3 and the other lead on pin 4, and check the voltage while toggling the sensor lever.	Open: +5 V Short: 0 V	
	^		2: GND	^
	^		3: Release 2	^
	^		4: GND	^
<i>CN7 (PW Sensor)</i>	1: E	Place one lead on pin 1 and the other lead on pin 2, and check the voltage while inserting and removing paper between the platen and sensor.	0 < Open Voltage (No paper) < Short Voltage (Paper loaded)	
	^		2: GND	^
	^		3: +5 V	^
	^		4: A	^
<i>CN2 (Case Open Sensor)</i>	1: COPEN	Place one lead on pin 1 and the other lead on pin 2, and check the voltage while toggling the sensor lever.	Open: +5 V (Case open) Short: 0 V (Case closed)	
	^		2: GND	^

5.2.3 Motors

Table 5-3 Motor Test Points

<i>Motor Connector Number</i>	<i>Common Pin Number</i>	<i>Test Pin Number</i>	<i>Test Method</i> (Set Meter to Ohms. Disconnect Motor from Main Board after the Printer is Powered off.)	<i>Meter Reading</i>
<i>CR Motor CN11</i>	5	1, 2, 3, 4	Place one lead on pin 5 and the other lead on each of 4 test pins.	$2.7 \Omega \pm 10 \%$ (at 25° C, 77° F)
<i>PF Motor CN10</i>	—	1, 2, 3, 4	Place one lead on pin 1 and other lead on pin 2. Place one lead on pin 3 and other lead on pin 4.	$16 \Omega \pm 10\%$ (at 25° C, 77° F)

5.2.4 Error Codes with Indicators and Buzzer

Table 5-4 Indicators and Buzzer

<i>Error Condition</i>	<i>Indicator</i>					<i>Buzzer</i> * 1
	<i>Pause</i>	<i>Paper Out</i>	<i>Tear Off / Bin</i>	<i>Pitch</i>	<i>Font</i>	<i>^</i>
<i>Paper Out</i>	On	On	—	—	—	○ × 3
<i>Paper Jam</i>	On	Blinks	—	—	—	● × 5
<i>Head Hot</i>	Blinks	—	—	—	—	—
<i>Cover Open</i>	On	—	—	—	—	○ × 3
<i>Fatal Error</i>	Blinks	Blinks	Blinks	Blinks	Blinks	● × 5

* 1: ○ indicates that the beep sounds for 100 ms with an interval of 100 ms.

● indicates that the beep sounds 500 ms with an interval of 100 ms.

5.3 UNIT LEVEL TROUBLESHOOTING

You may be able to identify the defective unit just from the symptom displayed. The table below provides the symptoms for a number of failures. Once you identify the problem, refer to the flowchart listed in the right-hand column of the table below to determine the cause of the problem.

Table 5-5. Symptoms and Problem Descriptions

<i>Symptom</i>	<i>Problem Description</i>	Flowchart No.
<i>Abnormal CR Operation</i>	<ul style="list-style-type: none"> • Carriage does not move at all. • When the printer is powered on, the CR moves away from home position after a moment and stops. All indicator LEDs on the control panel blink. 	Flowchart 1
<i>Abnormal Paper Feed</i>	<ul style="list-style-type: none"> • <i>Paper does not feed at all.</i> • <i>When the printer is powered on, paper is ejected automatically.</i> • When paper is loaded, it is ejected automatically and then the printer indicates “Ready.” 	Flowchart 2 Flowchart 2-1
<i>Abnormal Control Panel Operation</i>	<ul style="list-style-type: none"> • Control panel indicator LEDs do not light. • Operate button does not work. • Panel buttons do not operate. 	Flowchart 3
<i>Abnormal Printing</i>	<ul style="list-style-type: none"> • No image is printed. • Faulty printing — some dots are not printing. 	Flowchart 4

1. Abnormal CR Operation

2. Abnormal Paper Feed Operation 1

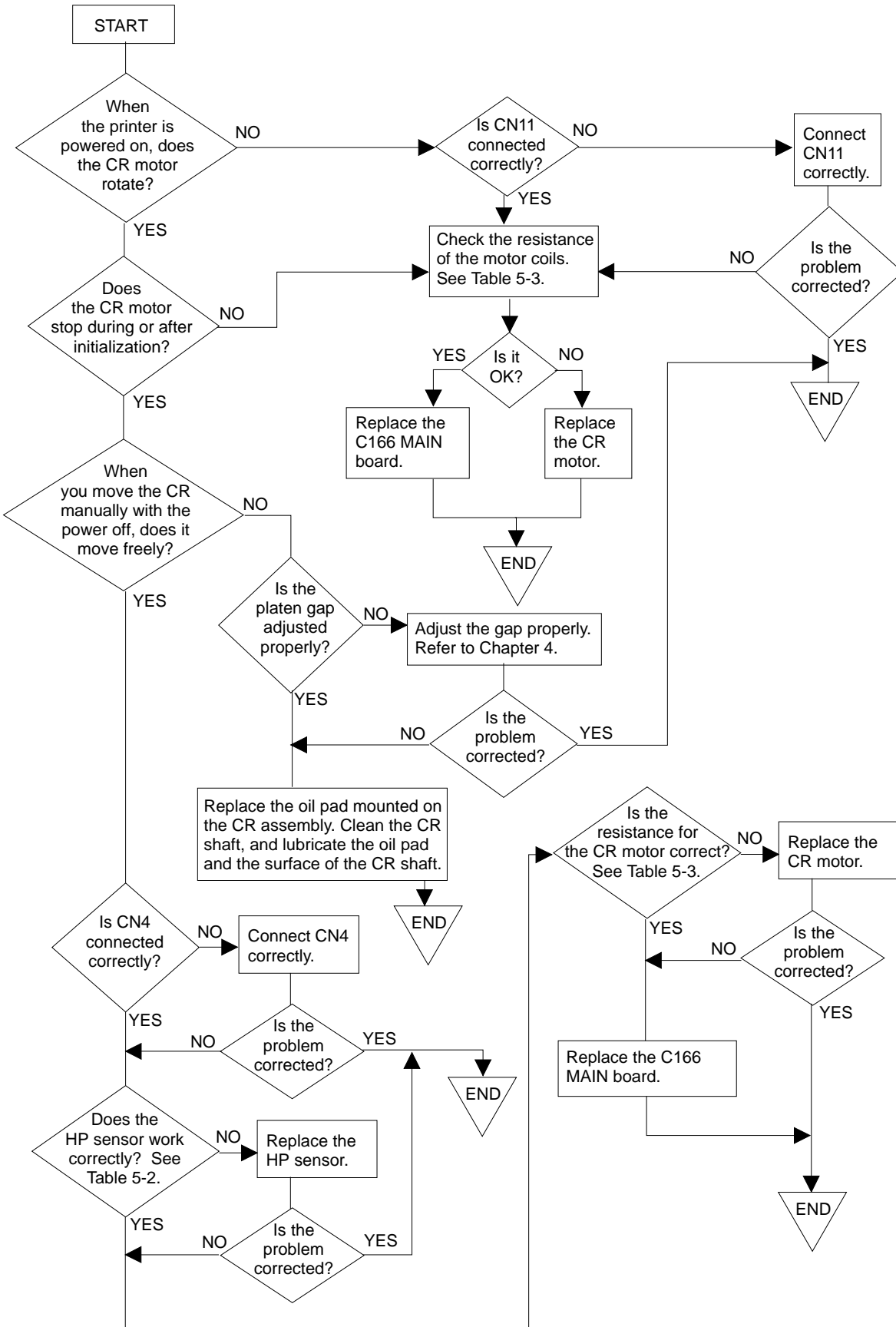

Figure 5-3 Flowchart 2

2. Abnormal Paper Feed Operation 2-1

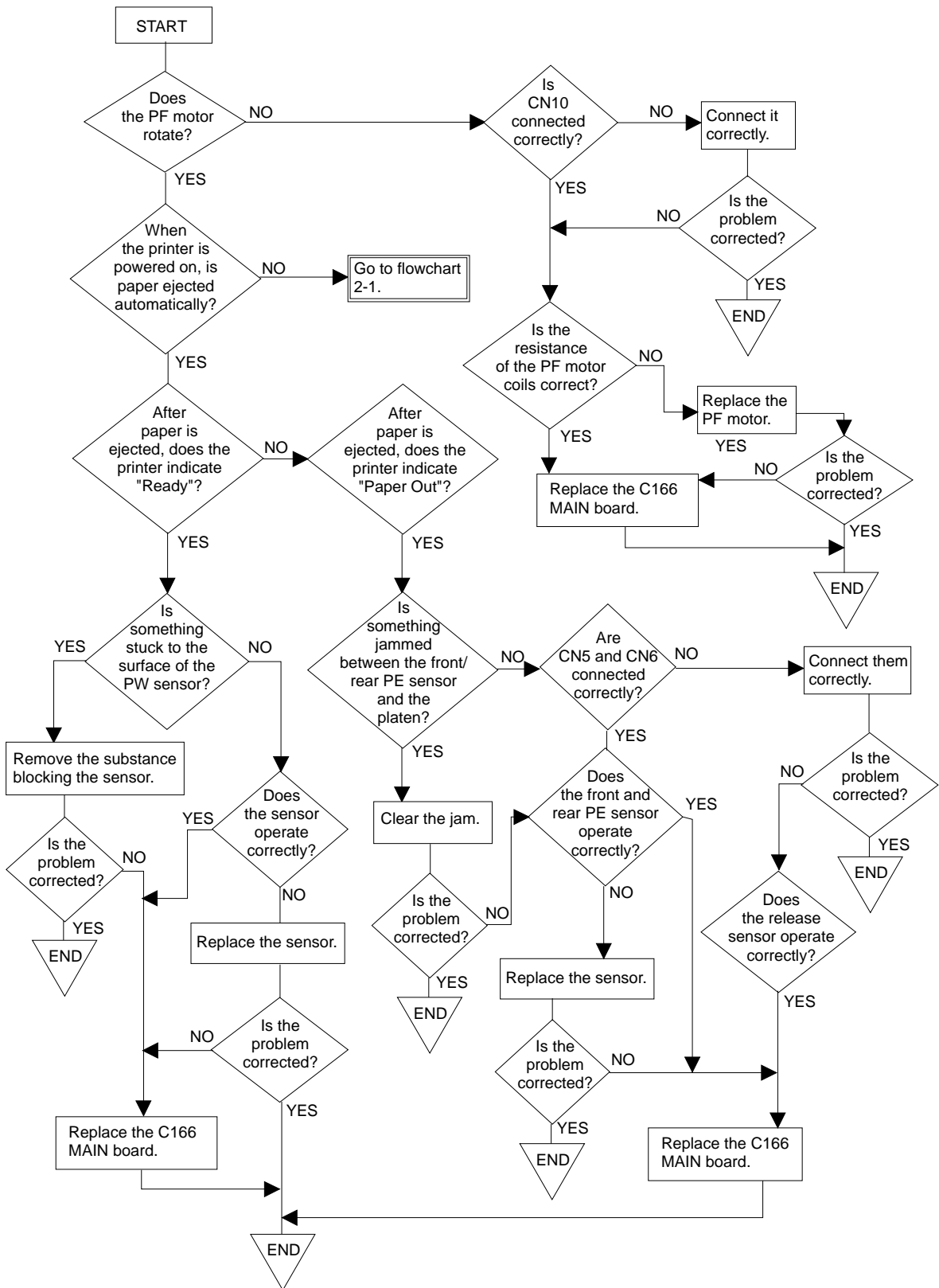

Figure 5-4 Flowchart 2-1

3. Abnormal Control Panel Operation

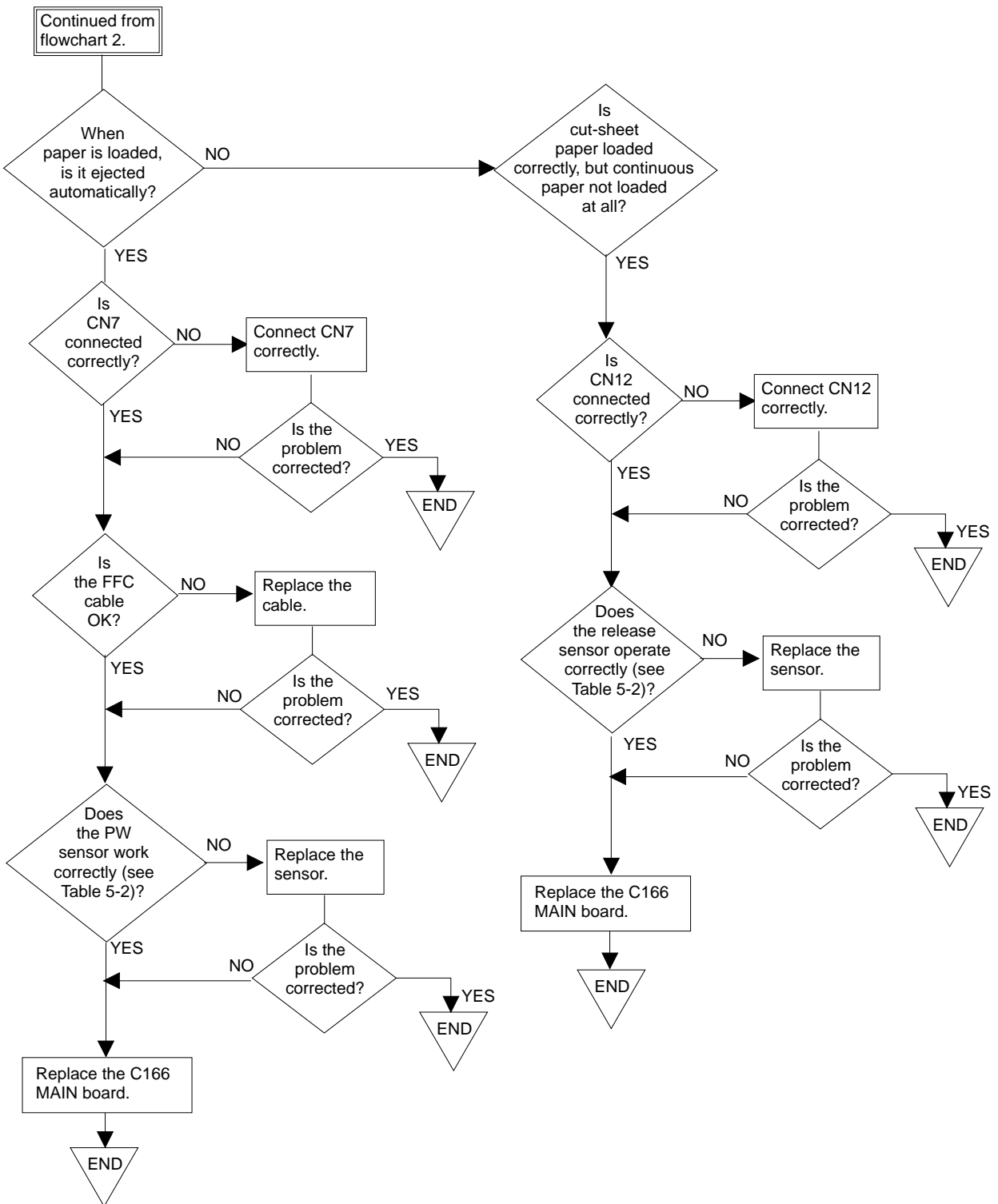

Figure 5-5 Flowchart 3

4. Abnormal Printing

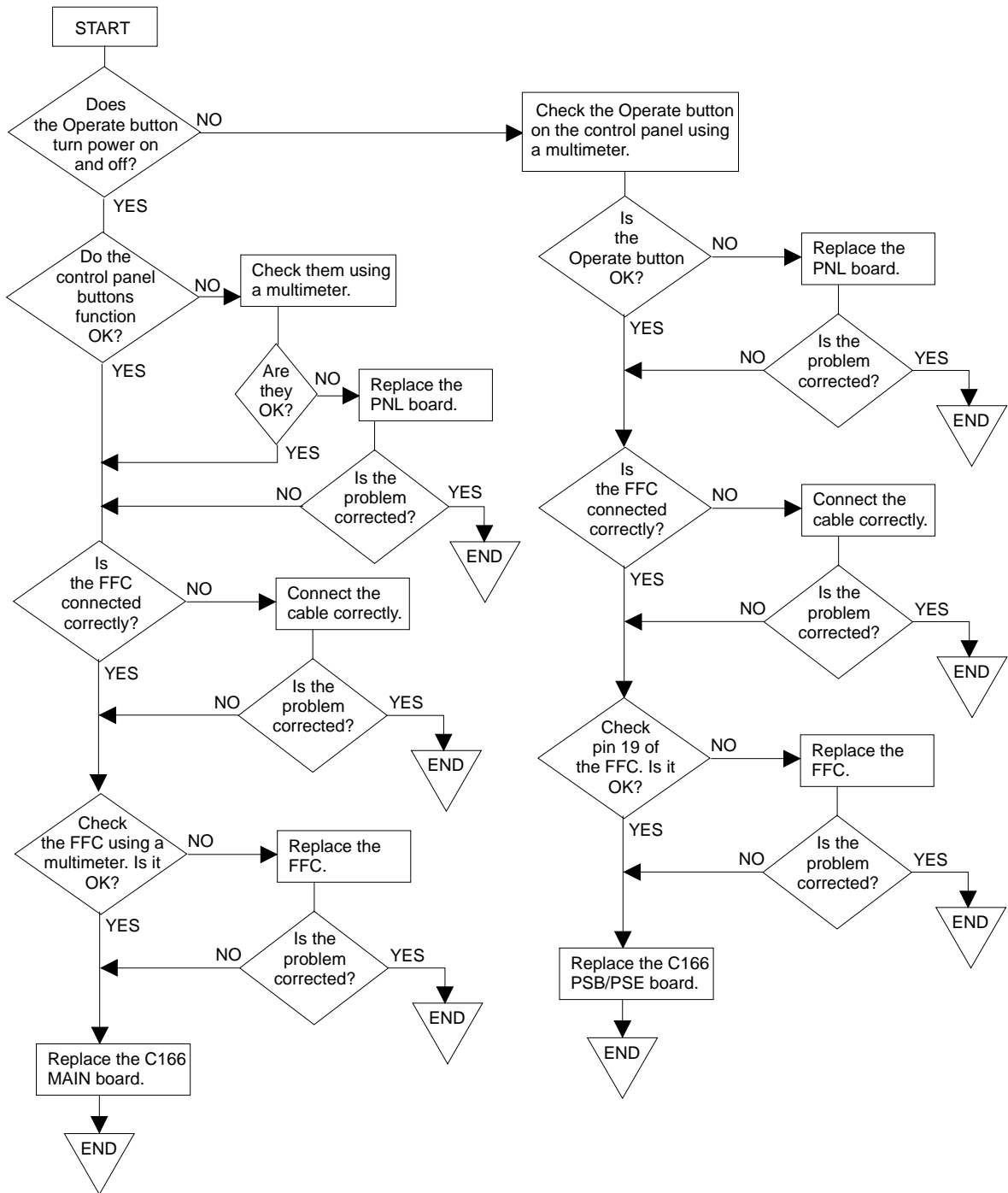

Figure 5-6 Flowchart 4

5.4 REPAIRING C165 PSB/PSE BOARD ASSEMBLY

This section provides instructions to repair a defective power supply board assembly. It describes various symptoms, likely causes, and checkpoints. Checkpoints refer to proper waveforms, resistances, and other values to check when evaluating the operation of any potentially faulty component. Check these values and take the appropriate action.

Note:

This information is necessary only for servicers who repair to the component level. Servicers who repair to the unit level (including all servicers in the U.S.) can ignore this section.

WARNING

The **OPERATE** switch on the control panel only turns the secondary power circuit on or off, so the primary circuit is live as long as the printer is connected to an AC power outlet. Before, you repair or touch the power supply board, be sure to disconnect the AC power outlet.

Table 5-6. Repairing the C165 PSB/PSE Board Assembly

Problem	Cause	Checkpoint	Solution
The 35 V and 5 V lines are not output when the printer is powered on.	The diode bridge DB1 is dead.	Measure the DC voltage between the pins 3 and 4 of the DB1.	Replace the DB1.
^	The transformer coil is open.	Measure the resistance of T1 transformer coils at pins 12-15, 9-11, 7-8, 3-4.	Replace the T1.
^	Q1 is dead.	Check that the resistance between the source and drain is infinite. Check the voltage waveform between the source and drain of the Q1. 	Replace the Q1.
	PC1 is dead.	Check the voltage waveform between pins 3 and 4 of the PC1. 	Replace PC1.

Table 5-6. Repairing the C165 PSB/PSE Board Assembly (Continued)

Problem	Cause	Checkpoint	Solution
The 35 V and 5 V lines are not output when the printer is powered on.	Q32 is dead.	Check that the resistance between the collector and emitter is infinite.	Replace the Q32.
^	Q31 is dead.	Check that the resistance between the source and drain is infinite.	Replace the Q31.
The +5 V line is not output.	IC51 is dead.	<p>Check the voltage waveform at pin 8 of IC51. The voltage waveform is as follows:</p>  <p>Check the voltage at pin 12 of IC51.</p>	Replace IC51.
^	Q51 is dead.	<p>Check the voltage waveform between emitter and collector of Q51.</p> 	Replace Q51.
^	L51 is short.	Check the resistance between both terminals of L51	Replace L51.
The PWDN signal is constantly HIGH.	IC52 is dead.	Check whether the voltage of pin 6 is more than 1.3 V or not. If the voltage is more than 1.3 V, IC52 is dead.	Replace IC52.

5.5 REPAIRING THE C165 MAIN BOARD ASSEMBLY

This section provides instructions to repair the C165 MAIN board assembly. It describes various problems, symptoms, likely causes, and solutions. The checkpoint column provides proper waveforms, resistance values, and other information for each component of C165 MAIN.

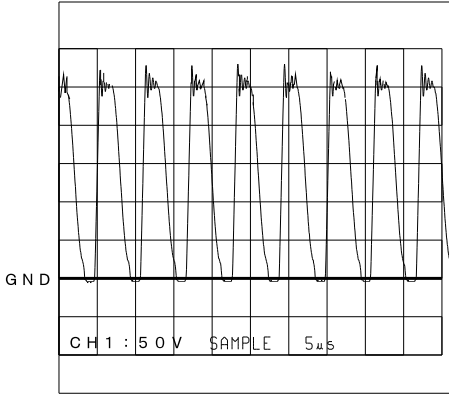
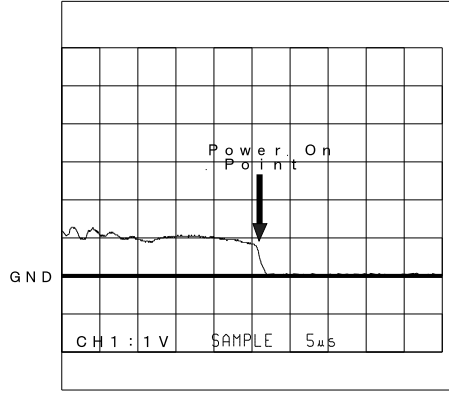
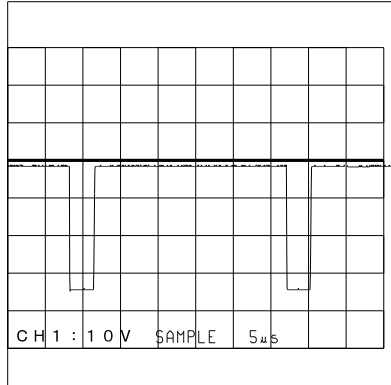
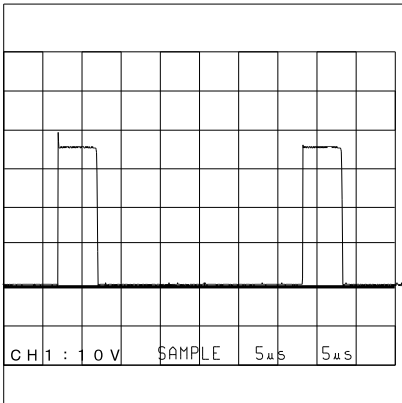
Note:

This information is necessary only for servicers who repair to the component level. Servicers who repair to the unit level (including all servicers in the U.S.) can ignore this section.

Table 5-7. Repairing the C165 MAIN Board Assembly

Problem	Cause	Checkpoint	Solution
<p>The printer does not operate at all.</p>	<p>Reset IC10 is defective.</p>	<p>Check the voltage waveforms of the VCC signal (CH1: IC10 pin 3) and VOUT signal (CH2: IC10 pin 1) when power is turned on.</p> 	<p>Replace IC10.</p>
<p>^</p>	<p>The PROM (IC3) is not selected.</p>	<p>Check for a change in the signal from HIGH/LOW at pin 137 of IC2.</p> 	<p>Replace IC2 (or replace the main board).</p>
<p>^</p>	<p>The PSRAM (IC5)</p>	<p>Check for a change in the signal from HIGH/LOW at pin 132 of the IC.</p>	<p>Replace IC2 (or replace the main board).</p>

Table 5-7. Repairing the C165 MAIN Board Assembly

Problem	Cause	Checkpoint	Solution
<p><i>The printer does not operate at all.</i></p>	<p>CRU1 is defective.</p>	<p>Check the oscillator signal at pins 26 or 27 of the CRU1</p> 	<p>If the signal is not correct, replace IC1 (or replace the main board). Otherwise, replace CRU1.</p>
<p><i>Carriage operation is abnormal.</i></p>	<p>IC11 or IC1 is defective.</p>	<p>Check input signal waveform (CH1) at pins 6, 5, 17, and 16 of IC1. Check output signal waveform (CH2) at pins 8, 1, 18, and 11 of IC12.</p> 	<p>If the input signal is not correct, replace IC1 (or replace the main board). If the output signal is not correct, replace IC12.</p>
	<p>IC2 is defective.</p>	<p>Check the output signal at pins 65, 64, 63, 62 of IC2</p>	<p>If there is no output signal, replace IC2.</p>

Table 5-7. Repairing the C165 MAIN Board Assembly

Problem	Cause	Checkpoint	Solution
<p><i>Paper feed is abnormal.</i></p>	<p>IC1 is defective. IC2 is defective. IC11 is defective.</p>	<p>Check input signal waveform at pins 43 and 26 of IC11. Check output signal waveform at pins 6, 3, 18, and 21.</p> 	<p>If the input signal is not correct, replace IC1 or IC2. If the input signal is correct and the output signal is not correct, replace the IC11.</p>
<p>No data is printed.</p>	<p>IC1 is defective.</p>	<p>Check the output signal waveform at pin 15 of IC1.</p> 	<p>If this signal is not output, replace IC1.</p>
<p>A particular dot fails to print.</p>	<p>IC2 is defective. One of the head drive transistors is defective (Q5 ~ Q28).</p>	<p>Check the voltage waveform (CH1) at pin 69 and pins 76 ~ 89, pins 91 ~ 99 of IC2. Check the voltage waveform (CH2) for each transistor.</p> 	<p>If the head drive signal is not output, replace IC2. If the head drive signal is output, replace the head drive transistor.</p>

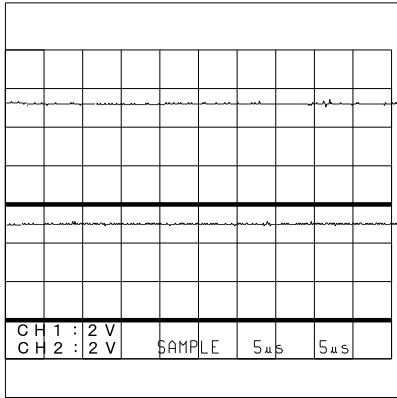
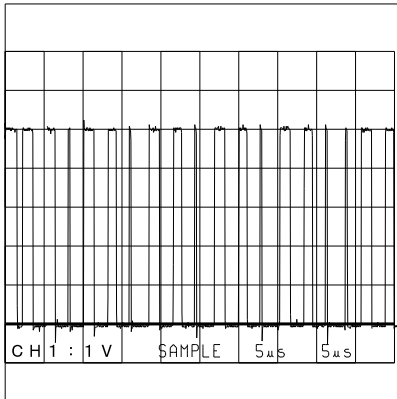
5.6 REPAIRING THE PRINTER MECHANISM

This section provides instructions for repairing the printer mechanism. It describes various problems, symptom, likely causes, checkpoints, and solutions. The checkpoint column shows items to be checked, including proper values to be set for each component of the printer mechanism. For replacement and adjustment instructions, see Chapter 3, Disassembly and Assembly, and Chapter 4, Adjustments. If the same symptom recurs after repair, select another item in the list of causes and repair the printer according to those instructions.

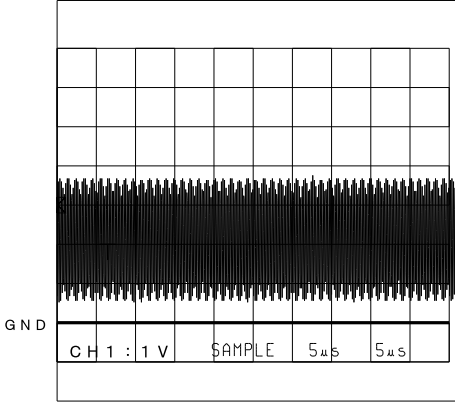
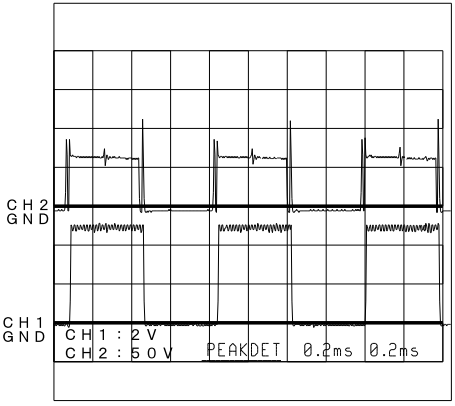
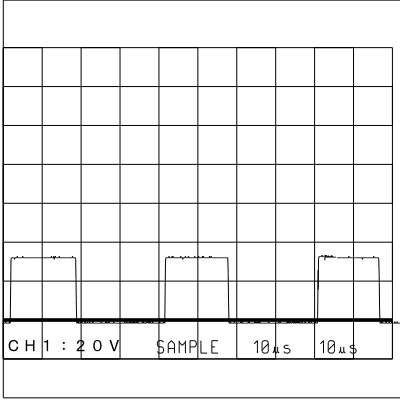
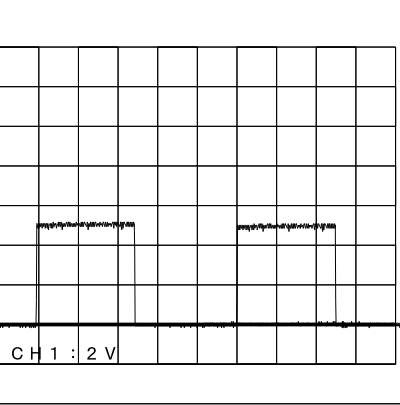
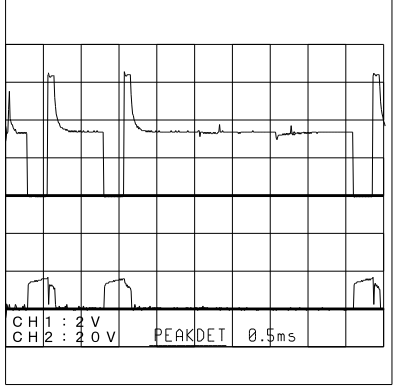
Table 5-8. Repairing the Printer Mechanism

Problem	Symptom	Cause	Checkpoint	Solution
<i>CR operation is abnormal.</i>	When the printer is powered on, the CR motor does not rotate at all.	The CR motor is defective.	Measure the coil resistance of the motor. Resistance is approximately 2.7 ohms.	Replace the CR motor. Refer to page 3-12.
^	When the printer is powered on, the CR motor does not rotate all and all indicators blink.	CN11 is disconnected from the main board.	Check CN11.	Connect CN11 correctly.
^	The CR motor can be rotated when the printer is powered on. But the CR does not move.	The timing belt came off the pinon gear of the CR motor.	Check the engagement of the timing belt.	Reinstall the timing belt correctly.
^	The CR moves slightly and then stops.	Platen gap is too narrow.	Manually move the CR and check that it moves smoothly. The proper platen gap is approximately 0.37 mm.	Adjust the platen gap properly. Refer to page 4-2.
^		Printer lacks lubrication or a foreign object is jammed between the oil pad and CR shaft.	Manually move the CR and check that it moves smoothly. Check the surface of the CR shaft and oil pad.	Replace or lubricate the oil pad. If any foreign object is jamming the carriage, remove it and clean the surface of the CR shaft. Then lubricate the CR shaft.
^		HP sensor is defective.	Check the operation of the HP sensor. Refer to page 5-2.	Replace the HP sensor. Refer the page 3-8.

Table 5-8. Repairing the Printer Mechanism

<i>Problem</i>	<i>Symptom</i>	<i>Cause</i>	<i>Checkpoint</i>	<i>Solution</i>
<i>CR operation is abnormal.</i>	The CR moves slightly and then stops.	A foreign object is jammed between both terminals of the HP sensor.	Check the HP sensor.	Remove the any foreign object.
^		CN4 connector removed from the HP sensor.	Check the connection of the connector.	Connect the CN4 correctly.
^	The CR moves to the left side (HP side) and strikes the frame of the printer.	The HP sensor is defective.	Check the operation of the HP sensor. Refer to page 5-2.	Replace the HP sensor.
<i>Printing is abnormal.</i>	No image is printed.	Common wires in the printhead FFC are disconnected or there is no continuity.	Check the common wires in the printhead FFC.	Replace the printhead FFC.
^	The printer does not print a particular dot.	The printhead is defective.	Measure the coil resistance of the printhead. The resistance should be approximately 16.4 ohms. Refer to page 5-1.	Replace the printhead.
^		The printhead FFC is disconnected, or there is no continuity.	Check the continuity in the FFC.	Replace the printhead FFC.
^	Printing is uneven on both edges of the column.	Platen parallelism is not adjusted properly.	Check the platen parallelism. Refer to page 4-2.	Adjust the platen parallelism.
^	The printed result is too light.	The printhead is defective.	Check if the tip of the dot wire is worn.	Replace the printhead.
^		The platen gap is too wide.	Check the platen gap. Refer to page 4-2.	Adjust the platen gap properly.
<i>Abnormal paper feed.</i>	The PF motor does not rotate at all.	The PF motor is defective.	Measure the coil resistance of the PF motor. The value is approximately 16 ohms.	Replace the PF motor.

Table 5-8. Repairing the Printer Mechanism

Problem	Symptom	Cause	Checkpoint	Solution
<i>Abnormal paper feed</i>	The PF motor does not rotate at all.	CN10 is disconnected from the main board.	Check CN10.	Connect CN10 correctly.
^		The rear or front PE sensor is defective.	Check the operation of the rear and front PE sensors. Refer to page 5-2.	Replace the rear or front PE sensor. Refer to page 3-23.
^		The rear or front PE sensor is not mounted correctly.	Check the mounting position.	Mount the rear or front PE sensor into the proper position.
^	When the printer is powered on, paper is ejected automatically, and then the printer becomes Ready.	A foreign substance is sticking to the surface of the PW sensor.	Check the surface of the PW sensor.	Remove the ribbon mask holder assembly, and remove any foreign objects.
^		The PW sensor is defective.	Check the operation of the PW sensor. Refer to page 5-2.	Replace the PW sensor. Refer to page 3-9.
^	When the printer is powered on, paper is ejected automatically, and then the printer signals a paper end error.	A foreign object is jammed between the platen and rear/front PE sensor.	Remove the platen, and check the paper path. Refer to page 3-10.	Remove the platen and remove any foreign object. Refer to page 3-10.
^		CN5 or CN6 is disconnected.	Check the connectors.	Connect the connector properly.
^		The rear/front PE sensor is defective.	Check the operation of the rear/front PE sensor. Refer to page 5-2.	Replace the rear/front PE sensor. Refer to page 3-23.
^	When paper is loaded, it is ejected automatically.	The FFC (CN7) for the PW sensor is disconnected.	Check the connector.	Connect the FFC properly.
^		The FFC is broken.	Check the continuity of the FFC using a multimeter.	Replace the FFC.
^		The PW sensor is defective.	Check the operation of the PW sensor. Refer to page 5-2.	Replace the PW sensor. Refer to page 3-9.

Table 5-8. Repairing the Printer Mechanism

Problem	Symptom	Cause	Checkpoint	Solution
<i>Paper feed is abnormal.</i>	Cut-sheet paper is loaded correctly, but continuous paper is not loaded at all.	CN12 is not connected correctly.	Check the connector. Refer to page 3-19.	Connect the CN12 correctly.
^		The release sensor is defective.	Check the operation of the release sensor. Refer to page 5-2.	Replace the release sensor. Refer to page 3-19.
<i>Ribbon feed is abnormal.</i>	The ribbon is not fed.	The ribbon cartridge is defective.	Remove the ribbon cartridge. Then rotate the ribbon feed roller manually to check that the ribbon cartridge feeds the ribbon normally.	Replace the ribbon cartridge.
^		Foreign substances are caught in the gears.	Check that the ribbon driving gear rotates properly when the carriage is moved manually.	Remove any foreign substances or replace the ribbon cartridge.
^	The ribbon feeds properly only when the carriage moves in one direction.	The planetary gear is defective.	Manually move the carriage and check that the planetary gear functions normally.	Replace the ribbon cartridge mechanism.

CHAPTER 6 Maintenance

Table of Contents

6.1 PREVENTIVE MAINTENANCE	6-1
6.2 APPLYING LUBRICATION	6-1

List of Figures

Figure 6-1. Lubrication Points 1 and 3	6-2
Figure 6-2. Lubrication Point 2	6-2
Figure 6-3. Lubrication Point 4	6-3
Figure 6-4. Lubrication Points 5, 6, and 7	6-3

List of Tables

Table 6-1. Lubrication	6-1
Table 6-2. Lubrication Points	6-1

6.1 PREVENTIVE MAINTENANCE

Preventive maintenance includes regular cleaning of the exterior case using denatured alcohol, as well as occasional vacuuming of the mechanism interior to remove dust and paper debris. After cleaning the unit, check that it is adequately lubricated, as described in Section 6.2, below. Before returning the printer to the customer, inspect springs, paper-feed rollers, and basic operation.

CAUTION

Disconnect the printer from the external AC power source before performing maintenance. Do not use thinner, trichloroethylene, or ketone-based solvents on the plastic components of the printer.

6.2 APPLYING LUBRICATION

EPSON recommends the printer be lubricated at the points illustrated in Figure 6-1. Table 6-2 lists each point along with its recommended lubricant. The recommended lubricants are EPSON G-26 and O-2, which have been tested extensively and found to comply with the needs of this printer. (Table 6-1 provides details about these lubricants.) Before applying a lubricant, be sure the surface to be lubricated is clean. Do not apply too much lubricant, as this may damage nearby parts.

Table 6-1. Lubrication

Type	Name	Quantity	Availability	Part No.
Grease	G-26	40 gm	EPSON	B702600001
Oil	O-2	40 cc	EPSON	B703700001

Table 6-2. Lubrication Points

Ref. No.	Lubrication Points	Quantity	Lubricant
1	Cam surface on the 34.5 mm spur gear	2 mm width, halfway	G-26
2	The platen gap adjustment slots on the right frame.	2 mm width, from the top slot to the 3rd from the bottom.	G-26
3	The shaft end of drive roller assembly and the cutout section on the left frame.	About 1/2 the size of a grain of rice	G-26
4	Oil pad	half of the pad	O-2
5	RD planetary shaft and planetary lever leaf spring	About 1/2 the size of a grain of rice.	G-26
6	RD housing Side of shafts: 3 points Inside hole: 1 point	About 1/2 the size of a grain of rice	G-26
7	RD Assembly Gear teeth: 5 points	About 1/2 the size of a grain of rice	G-26

Note: Lubrication must be applied during the reassembly process.

For lubrication points, refer to the figure on the next page.

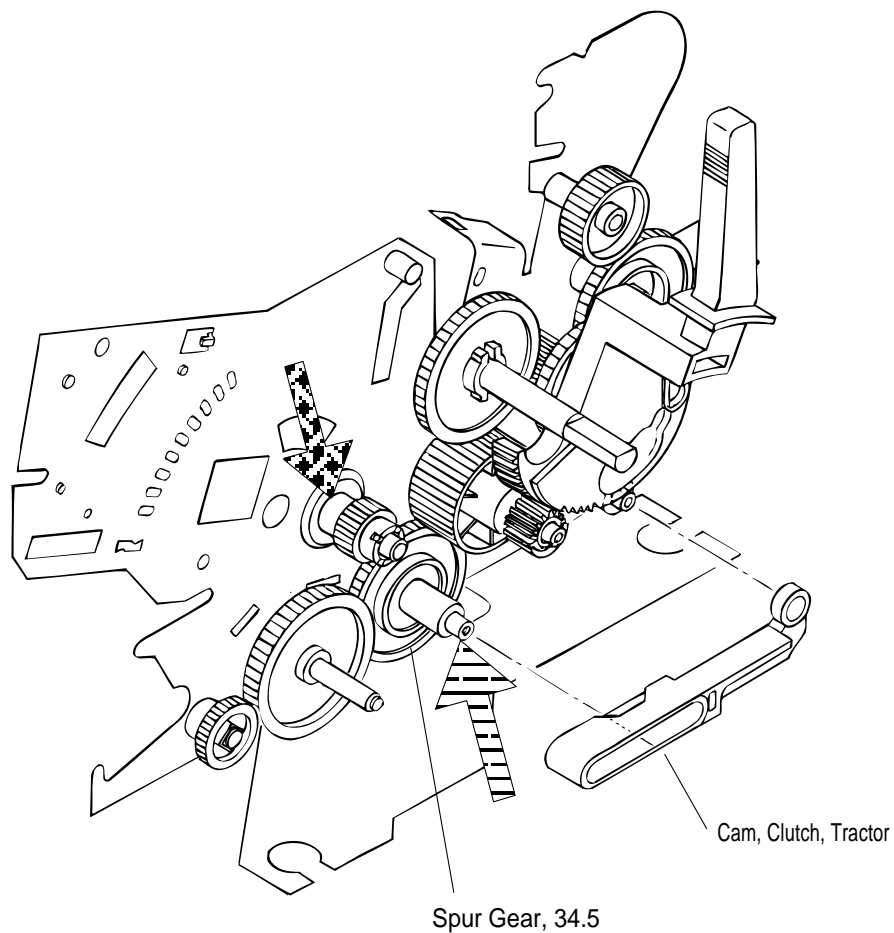

→ : Lubrication Point Ref. No.(1)

→ : Lubrication Point Ref. No.(3)

Figure 6-1. Lubrication Points 1 and 3

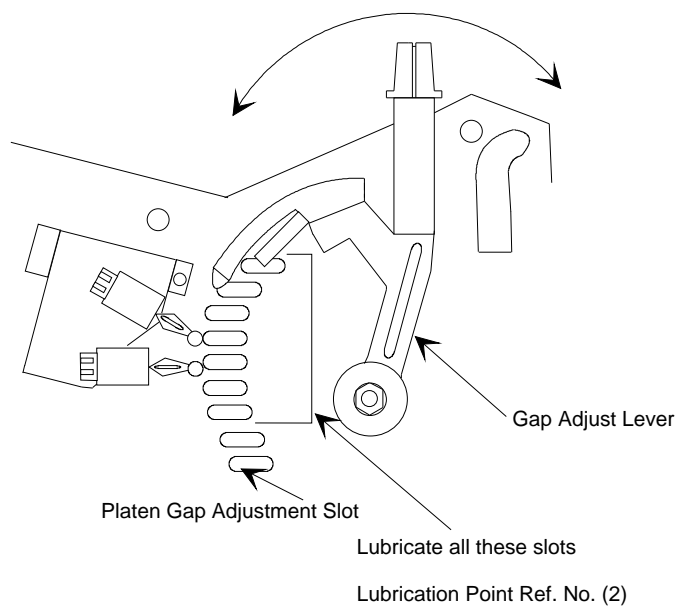

Figure 6-2. Lubrication Point 2

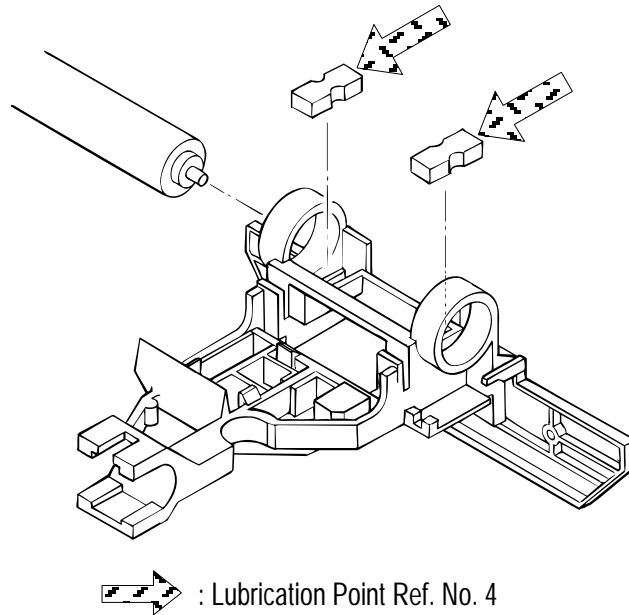

Figure 6-3. Lubrication Point 4

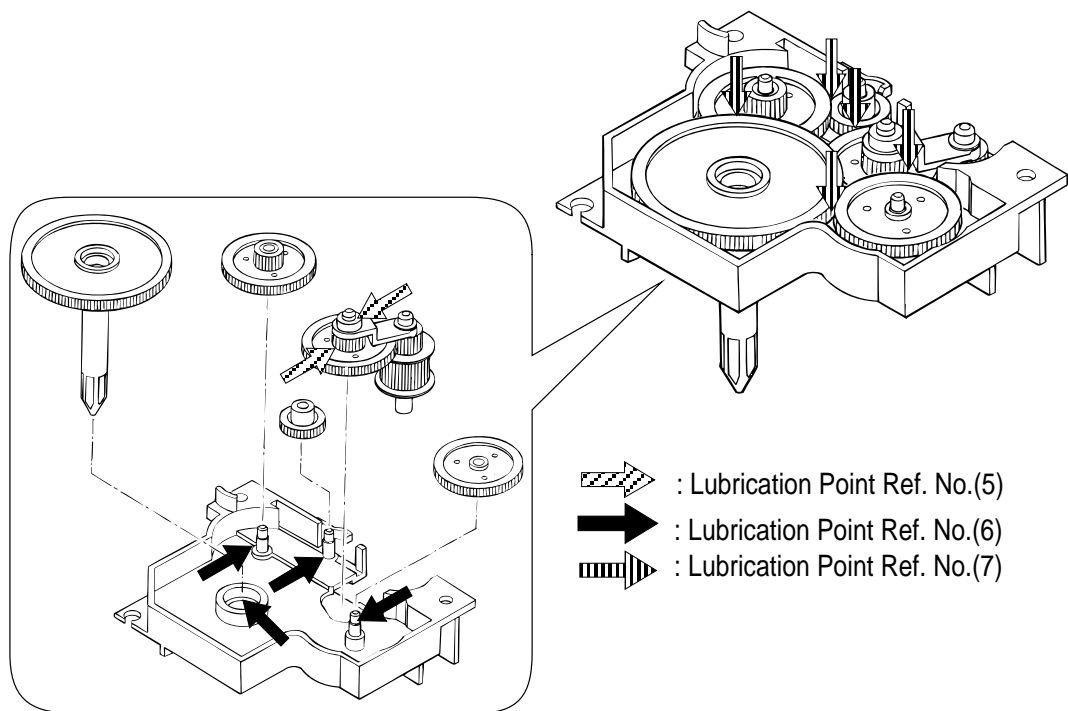

Figure 6-4. Lubrication Points 5, 6, and 7

Appendix

Table of Contents

A.1. EXPANDED PRODUCTION COMMANDS	A-1
A.2. EEPROM ADDRESS MAP	A-2
A.3 CONNECTOR SUMMARY	A-5
A.4 CIRCUIT DIAGRAMS	A-11
A.5 CIRCUIT BOARD COMPONENT LAYOUTS	A-17
A.6 EXPLODED DIAGRAMS	A-20

List of Figures

Figure A-1. Cable Connections	A-5
Figure A-2. C165 MAIN Board Assembly Circuit Diagram.	A-11
Figure A-3. C165 PSB Board Assembly Circuit Diagram.	A-13
Figure A-4. C165 PSE Board Assembly Circuit Diagram.	A-15
Figure A-5. C165 MAIN Board Assembly Component Layout.	A-17
Figure A-6. C165 PSB Board Assembly Component Layout.	A-18
Figure A-7. C165 PSE Board Assembly Component Layout.	A-19
Figure A-8. LQ-2170 Exploded Diagrams (1).	A-20
Figure A-9. LQ-2170 Exploded Diagrams (2).	A-21
Figure A-10. LQ-2170 Exploded Diagrams (3).	A-22
Figure A-11. CSF Bin 1 Exploded Diagrams (1)	A-23
Figure A-12. CSF Bin 1 Exploded Diagrams (2)	A-24
Figure A-13. CSF Bin 2 Exploded Diagrams	A-25

List of Tables

Table A-1. Connector Summary.	A-6
Table A-2. Connector Pin Assignments – CN3	A-6
Table A-3. Connector Pin Assignments – CN4	A-6
Table A-4. Connector Pin Assignments – CN5	A-7
Table A-5. Connector Pin Assignments – CN6	A-7
Table A-6. Connector Pin Assignments – CN7	A-7
Table A-7. Connector Pin Assignments – CN8	A-8
Table A-8. Connector Pin Assignments – CN9	A-8
Table A-9. Connector Pin Assignments – CN10	A-8
Table A-10. Connector Pin Assignments - CN11.	A-8
Table A-11. Connector Pin Assignments - CN12.	A-8
Table A-12. Connector Pin Assignments - CN13.	A-9
Table A-13. Connector Pin Assignments - CN14.	A-9
Table A-14. Connector Pin Assignments - CN15.	A-9

A.1 EXPANDED PRODUCTION COMMANDS

1. Write Bidirectional Adjustment Data to EEPROM

- Format 1B 7C 00 06 00 00 FF 00 (in hex) *dl d2 d3*
- Parameters *dl* Print speed (0: High speed draft /Draft, 1: Draft copy 2: LQ)
d2, d3 Bi-d adjustment data to be written (units = 1/720 inch)

<i>n</i> = FFF4H (-12)	12/720 inch to the right
<i>n</i> = FFFFH (-1)	2/720 inch to the right
<i>n</i> = FFFEH (-2)	1/720 inch to the right
<i>n</i> = 0000H (±0)	
<i>n</i> = 0001H (+1)	1/720 inch to the left
<i>n</i> = 0002H (+2)	2/720 inch to the left
<i>n</i> = 000CH (+12)	12/720 inch to the left
- Range *dl* 0, 1, or 2
d2, d3 $-12 \leq n \leq +12$ ($n = d2 + d3 \times 256$)

2. Print Data for Selected EEPROM Address

- Format 1B 7C 00 04 00 01 FE 80 (in hex) *dl*
- Parameter *dl* EEPROM address
- Range *dl* $00H \leq dl \leq 7FH$

3. Write Data to Specific EEPROM Address

- Format 1B 7C 00 05 00 04 FB 02 (in hex) *dl d2*
- Parameters *dl* EEPROM address
d2 Byte of data to be written
- Range *dl* $00H \leq dl \leq 7FH$
d2 $00H \leq d2 \leq FFH$ (Will not accept addresses 00H or 02H)

4. Set Print Mode

- Format 1B 7C 00 04 00 03 FC 81 (in hex) *dl*
- Parameter *dl* Print speed
 bit 0: ESC mode (1) / not fixed (0)
 bit 1: Head hot mode (1) / not fixed (0)
 bit 2: Head cold mode (1) / not fixed (0)
 bit 3: Heavy duty mode (1) / not fixed (0)
 bit 4: Thick paper mode (1) / not fixed (0)
 bit 5: Reserved
 bit 6: Power down mode (1) / not fixed (0)
 bit 7: Normal mode (1) / not fixed (0)
- Range $00H \leq dl \leq 05H$

5. Compare Data at Selected EEPROM Addresses

- Format 1B 7C 00 05 00 05 FA 82 (in hex) *d1 d2*
- Parameters *dl* EEPROM address
d2 Address of data to be compared
- Range *d1* $00H \leq d1 \leq 7FH$
d2 $00H \leq d2 \leq FFH$

A.2 EEPROM ADDRESS MAP

Address	Data	Data Format	Default
00H, 01H	Reserved		0000H
Area 1			
02H, 03H	Character table selection	0: PC437 1: PC850 2: PC860 3: PC863 4: PC865 5: PC861 6: BRASCII 7: Abicomp 8: ISO Latin 1 9: Roman8, 10: PC437Greek 11: PC852 12: PC853 13: PC855 14: 857 15: PC864 16: PC866 17: PC869 18: ISOLatin1T 19: ISO8859-7 20: MAZOWAI 21: Code MJK 22: Bulgaria 23: Estonia 24: PC774 25: ISO Latin2 26: PC866 LAT.	0000H (PC437)
04H, 05H	Page length for rear tractor	1 to 22 x 360 (in units of 1/360 inch), 0000H: 11 inches (same as default)	0F78H (11")
06H, 07H	Page length for front tractor	1 to 22 x 360 (in units of 1/360 inch), 0000H: 11 inches (same as default)	0F78H (11")
08H, 09H	Page length for CSF bin 1	1 to 22 x 360 (in units of 1/360 inch), 0000H: 22 inches (same as default)	1EF0H (22")
0AH, 0BH	Page length for CSF bin 2	1 to 22 x 360 (in units of 1/360 inch), 0000H: 22 inches (same as default)	1EF0H (22")
0CH, 0DH	TOF adjustment value for rear tractor	-60 to 360 (4.2 mm to 8.5 mm + 1 inch, in units of 1/360 inch)	0000H (8.5 mm)
0EH, 0FH	TOF adjustment value for front tractor	-60 to 360 (4.2 mm to 8.5 mm + 1 inch, in units of 1/360 inch)	0000H (8.5 mm)
10H,11H	TOF adjustment value for front CSF bin1	-60 to 360 (4.2 mm to 8.5 mm + 1 inch, in units of 1/360 inch)	0000H (8.5 mm)
12H,13H	TOF adjustment value for front CSF bin2	-60 to 360 (4.2 mm to 8.5 mm + 1 inch, in units of 1/360 inch)	0000H (8.5 mm)
14H,15H	TOF adjustment value for rear manual insertion	-60 to 360 (4.2 mm to 8.5 mm + 1 inch, in units of 1/360 inch)	0000H (8.5 mm)
16H,17H	TOF adjustment value for front manual insertion	-60 to 360 (4.2 mm to 8.5 mm+1 inch, in units of 1/360 inch)	0000H (8.5 mm)
18H,19H	Bottom margin for front tractor	1 to 22 x 360 (in units of 1/360 inch), 0000H: 11 inches (same as default)	0F78H (11")
1AH,1BH	Bottom margin for rear tractor	1 to 22 x 360 (in units of 1/360 inch), 0000H:11inches (same as default)	0F78H (11")
1CH	Front selection	0: Roman, 1: Draft , 2: Sans serif , 3:Courier 4: Prestige, 5: Script , 6:Others (Default Setting Font)	00H (Roman)
1DH	Pitch selection	0:10 cpi, 1: 12 cpi, 2: 15 cpi, 3: 17 cpi, 4: 20 cpi, 5: Proportional	00H (10 cpi)

* Assignment of data for two or more bytes is sequential: from lower byte to lower address, and from higher byte to higher address.

Address	Data	Data Format	Default
1EH	Reserved		0000H
1FH	Pitch direction setting	0: Bi-d, 1: Uni-d	00H
20H	I/F mode selection	0: Auto I/F Selection, 1: Parallel I/F, 2: Type-B I/F	00H (Auto)
21H	Auto I/F wait time setting	10: 10 Sec., 30: 30 Sec., 00: 10 Sec.	0AH (10 sec.)
22H	Auto line feed Auto tear off Skip over perforation High speed draft Input buffer _____ _____ _____	b0: Auto line feed 0: Off 1: On b1: Auto tear off 0: Off 1: On b2: Skip over perforation 0: Off 1: On b3: High speed draft 0: On 1: Off b4: Input buffer 0: On 1: Off b5: Reserved b6: Reserved b7: Reserved)	00H
23H	Software 0 slashed Buzzer Roll paper Auto CR A.G.M. _____ _____	b0: Software 0: ESC/P 1: IBM2381 Plus b1: 0 slashed 0: Off 1: On b2: Buzzer 0: On 1: Off b3: Roll paper 0: Off 1: On b4: Auto CR (IBM) 0: Off 1: On b5: A.G.M. (IBM) 0: Off 1: On b6: Reserved b7: Reserved	00H
24H, 25H	Tear Off adjustment	-128 to +127 (in units of 1/360 inch)	0000H
26H	Other font selection	0: Roman T , 1: Sans Serif H , 2: OCR-B 3: Orator , 4:Orator-S , 5: Script C	00H
27H	Backup flags 1 Copy mode		00H
28H	Backup flags 2 In tear-off state Bin select	b0: Friction Bin 1 or Tractor not Tear Off b1: Friction Bin 1 b2: Friction Bin 2 b3: Friction (Card Stock) b4: Tractor and Tear off	00H
29H	Panel mask pattern 1	b0: LOAD function b1: EJECT function b2: FONT selection b3: PITCH selection b4: TEAR OFF function b5: BIN selection b6: Draft self test b7: LQ self test	00H
2AH	Panel mask pattern 2	b0: LF function b1: FF function b2: MICRO ADJUST function b3: PAUSE function b4: Data dump b5: Default setting b6: Bi-d adjustment b7: Reserved	00H

* Assignment of data for two or more bytes is sequential: from lower byte to lower address, and from higher byte to higher address.

Address	Data	Data Format	Default
2BH	Manual feed wait time	3 to 30 (in units of 0.1 sec.), 00H: 0.3 sec. (same as default)	03H (0.3 sec.)
2CH 1	Tear-off wait time	3 to 30 (in units of 0.1 sec.) , 00H: 0.3 sec. (same as default)	03H (0.3 sec.)
2DH, 2EH	Reserved		00H
2FH, 33H	Reserved		00H
34H, 53H	Reserved		00H
54H, 5DH	Reserved		00H
5EH, 5FH	Paper edge length		00H
60H, 61H	Paper length for rear manual insertion	1 to 22 x 360 (in units of 1/360 inch 0000H: 22 inches (same as default)	1EF0H (22")
62H, 63H	Paper length for front manual insertion	1 to 22 x 360 (in units of 1/360 inch 0000H: 22 inches (same as default)	1EF0H (22")
64H to 66H	Sub number for customization	00H to 09H	000000H Standard
67H	Reserved		00H
Area 2			
68H	Market	0: Standard version, 1: NLSP version	00H
69H to 70H	Reserved		00H
71H	Checksum of Area 2 (68-70H)		00H
Area 3			
72H	Vp adjustment value		80H
73H	Vp adjustment value(complement of 72H)		7FH
74H	Bi-d adjustment value for high speed draft / draft mode	-12 to +12 (in units of 1/720 inch)	00H
75 H	Bi-d adjustment value for draft copy mode	-12 to +12 (in units of 1/720 inch)	00H
76H	Bi-d adjustment value for LQ mode	-12 to +12 (in units of 1/720 inch)	00H
77H	Reserved		00H
78H	TPE level		FFH
79H	TPE adjustment position	-10 to +10 (in units of 1/180 inch)	00H
7AH to 7EH	Reserved		00H
7FH	Reserved		00H

* EEPROM data in Area 3 is set for each printer in the factory. Do not change this data afterwards.

A.3 CONNECTOR SUMMARY

Figure A-1 illustrates how primary components are connected. Table A-1 summarizes functions and sizes of the connectors.

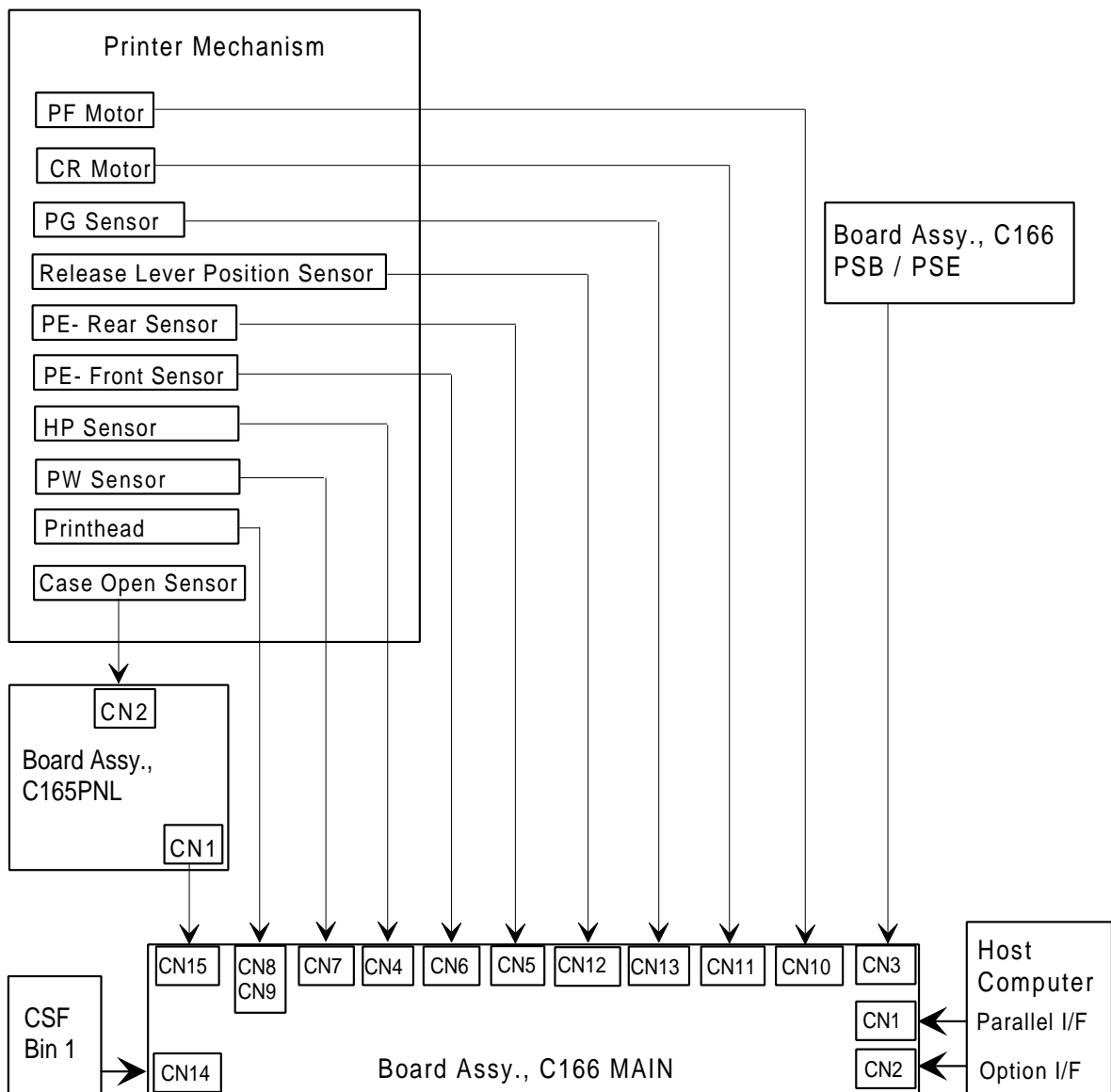

Figure A-1. Cable Connections

Table A-1. Connector Summary

Board	Connector	Function	Pins
MAIN Board Assembly	CN1	Parallel interface	36
	CN2	Type B interface	36
	CN3	C165 PSB/PSE board assembly	12
	CN4	HP sensor	3
	CN5	Rear PE sensor	3
	CN6	Front PE sensor	2
	CN7	PW sensor	4
	CN8	Printhead	18
	CN9	Printhead	16
	CN10	PF motor	4
	CN11	CR motor	5
	CN12	Release lever position sensor	4
	CN13	PG sensor	2
	CN14	CSF bin 1	10
	CN15	PNL board assembly	22

Table A-2. Connector Pin Assignments – CN3

Pin	I/O	Signal Name	Function
1	---	GP	---
2	---	GP	---
3	---	GP	---
4	I	+35V	+35 VDC line
5	I	+35V	+35 VDC line
6	I	+35 V	+35 VDC line
7	---	GND	---
8	---	GND	---
9	I	+5V	+5VDC line
10	I	+5V	+5VDC line
11	I	PWDN	+35 V line overload setection signal
12	O	PSC	Power on/off switch signal

Table A-3. Connector Pin Assignments – CN4

Pin	I/O	Signal Name	Function
1	I	HP	CR home position signal
2	---	GND	Signal GND
3	—	+5V	+5 VDC

Table A-4. Connector Pin Assignments – CN5

Pin	I/O	Signal Name	Function
1	---	+5V	+5 VDC
2	I	PE	Rear paper end signal
3	—	GND	Signal ground

Table A-5. Connector Pin Assignments – CN6

Pin	I/O	Signal Name	Function
1	I	PE	Front paper end signal
2	---	GND	Signal GND

Table A-6. Connector Pin Assignments - CN7

Pin	I/O	Signal Name	Function
1	I	E	TOP paper end signal
2	---	GND	Signal GND
3	---	+5V	+5 VDC line
4	---	A	+5 VDC line

Table A-7. Connector Pin Assignments – CN8

Pin	I/O	Signal Name	Function
1	O	HD5	Head Data 5
2	O	HD1	Head data 1
3	O	HD13	Head data 13
4	O	HD17	Head data 17
5	O	HD9	Head data 9
6	---	+35V	+35 VDC line
7	O	HD21	Head data 21
8	O	HD24	Head data 24
9	---	+35V	+35 VDC line
10	O	HD16	Head data 16
11	---	+35V	+35 VDC line
12	---	+35V	+35 VDC line
13	O	HD20	Head data 20
14	O	HD8	Head data 8
15	O	HD12	Head data 12
16	I	HTMP	Head temperature signal
17	---	+5V	+5 VDC line
18	O	HD4	Head data 4

Table A-8. Connector Pin Assignments – CN9

Pin	I/O	Signal Name	Function
1	O	HD3	Head data 3
2	O	HD11	Head data 11
3	O	HD19	Head data 19
4	—	+35V	+35 VDC line
5	O	HD2	Head data 2
6	—	+35V	+35 VDC line
7	O	HD7	Head data 7
8	O	HD22	Head data 22
9	O	HD15	Head data 15
10	—	+35V	+35 VDC line
11	O	HD23	Head data 23
12	—	+35V	+35 VDC line
13	O	HD14	Head data 14
14	O	HD18	Head data 18
15	O	HD6	Head data 6
16	O	HD10	Head data 10

Table A-9. Connector Pin Assignments – CN10

Pin	I/O	Signal Name	Function
1	O	PF A	PF motor phase A
2	O	PF B	PF motor phase B
3	O	PF –A	PF motor phase –A
4	O	PF –B	PF motor phase –B

Table A-10. Connector Pin Assignments – CN11

Pin	I/O	Signal Name	Function
1	O	CR A	CR motor phase A
2	O	CR –A	CR motor phase –A
3	O	CR B	CR motor phase B
4	O	CR –B	CR motor phase –B
5	O	CR COM	CR motor common

Table A-11. Connector Pin Assignments – CN12

Pin	I/O	Signal Name	Function
1	I	RELEASE1	Release sensor 1 signal
2	—	GND	Signal GND
3	I	RELEASE2	Release sensor 2 signal
4	—	GND	Signal GND

Table A-12. Connector Pin Assignments - CN13

Pin	I/O	Signal Name	Function
1	I	PG1	Platen gap sensor signal
2	—	GND	Signal GND

Table A-13 Connector Pin Assignments – CN14

Pin	I/O	Signal Name	Function
1	O	A	CSF motor phase A
2	O	B	CSF motor phase B
3	O	-A	CSF motor phase -A
4	O	-B	CSF motor phase -B
5	O	HOLD	CSF motor hold signal
6	—	+5V	+5 VDC line
7	—	GND	Signal GND
8	—	GND	Signal GND
9	—	+35V	+35 VDC line
10	—	+35V	+35 VDC line

Table A-14 Connector Pin Assignments – CN15

Pin	I/O	Signal Name	Function
1	I	COPEN	Case open sensor signal
2	O	PAUSEL	Pause LED signal
3	—	+5V	+5 VDC line
4	O	POUTL	Paper out LED signal
5	O	RESRVL	Pitch select LED
6	I	PAUSSW	Pause button signal
7	O	TBIN2L	Tear off/ bin select LED
8	O	TBIN1L	Tear off/ bin select LED
9	O	PITC1L	Pitch select LED
10	O	PITC2L	Pitch select LED
11	—	FONT3L	Not connected
12	O	FONT2L	Font LED
13	O	FONT1L	Font LED
14	—	GND	Signal GND
15	—	GND	Signal GND
16	I	FONTSW	Font button signal
17	I	PITCSW	Pitch button signal
18	I	TBINSW	Tear off/ bin signal
19	I	PSC	Operate button signal
20	I	LDEJSW	Load / Eject button signal
21	I	LFFFSW	LF / FF button signal
22	—	FG	Frame GND

A.4 CIRCUIT DIAGRAMS

Figure A-2. C165 MAIN Board Assembly Circuit Diagram

Figure A-3. C165 PSB Board Assembly Circuit Diagram

Figure A-4. C165 PSE Board Assembly Circuit Diagram

A.5 CIRCUIT BOARD COMPONENT LAYOUTS

Figure A-5. C165 MAIN Board Assembly Component Layout

Figure A-6. C165 PSB Board Assembly Component Layout

Figure A-7 C165 PSE Board Assembly Component Layout

A.6 EXPLODED DIAGRAMS

Figure A-8. LQ-2170 Exploded Diagrams (1)

Figure A-9. LQ-2170 Exploded Diagrams (2)

Figure A-10. LQ-2170 Exploded Diagrams (3)

Figure A-11. C.S.F. Bin1 Exploded Diagrams (1)

Figure A-12. C.S.F. Bin1 Exploded Diagrams (2)

Figure A-13. C.S.F. Bin2 Exploded Diagrams

Table A-15 Part No. Reference Table

Table A-15 Part No. Reference Table (Continue)

EPSON

Printed in Japan

95.12-05-S